



High Pressure Ball Joint Swivel Pipe Connectors
Engineered Solutions For Pipe Motion



www.thorburnflex.com



Thorburn's Ball Joint Swivel Pipe Connector is a high pressure joint that compensates for movement of piping spools and equipment while maintaining sealing integrity and relieving piping stresses. It is designed with a high temperature, high pressure Graphoil™ seal that is easily serviced through a field service injection port in the connector casing. It is suitable for both dynamic and static industrial applications such as steam, petrochemical and marine service. Thorburn's Model BJUS provides oscillating by-directional movement through to 360° continuous rotation while Model BJFS provides an additional flexible gimbal pivot movement of a maximum of 30°.

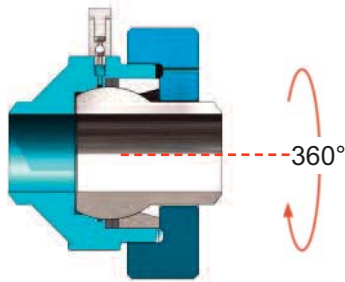

Model BJUS

- Provides oscillating by-directional movement through to 360° Continuous rotation
- Specifically designed for applications where restricted movement is required

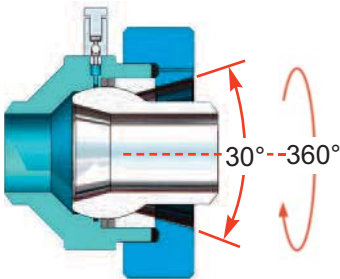

Model BJFS

- Provides oscillating by-directional movement through to 360° Continuous rotation and a 30° angular pivot
- Reduces piping stress where thermal expansion and mechanical movement are present in the piping system

Features

- 360° continuous rotation and up to 30° axial pivot
- Adds flexibility to piping spools
- Compensates for thermal expansion, misalignment, and shifting equipment
- Field injection port for inline service maintenance
- Compact design pre-assembled with butt weld and flanged ends
- Reliable high-temperature, high-pressure Graphoil™ seals

Specifications

Sizes: 1 in to 24 in (Din 25 to Din 600)

Pressure Ratings: Up To ASME Class 2500

Test Pressure: 1.5 X design pressure

Temperature Range: Up to 1000°F (538°C)

Materials: SA105N, SA479/182 Type 316SS, SA276 Type 2205 (Super Duplex SS)

Design Codes

- ASME B31.1, B31.3
- ASTM F1298 (Flexible Expansion Type Ball Joints For Marine Applications)
- API 6FA (Fire Test Valves)
- ISO 9001:2015

Ball Joint Swivel Components

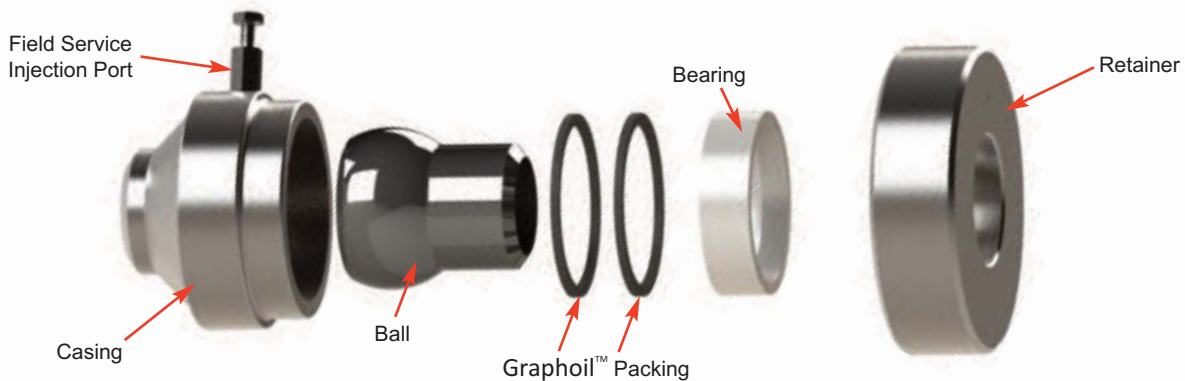

Series BJUS/BJFS Typical Pipe Movements

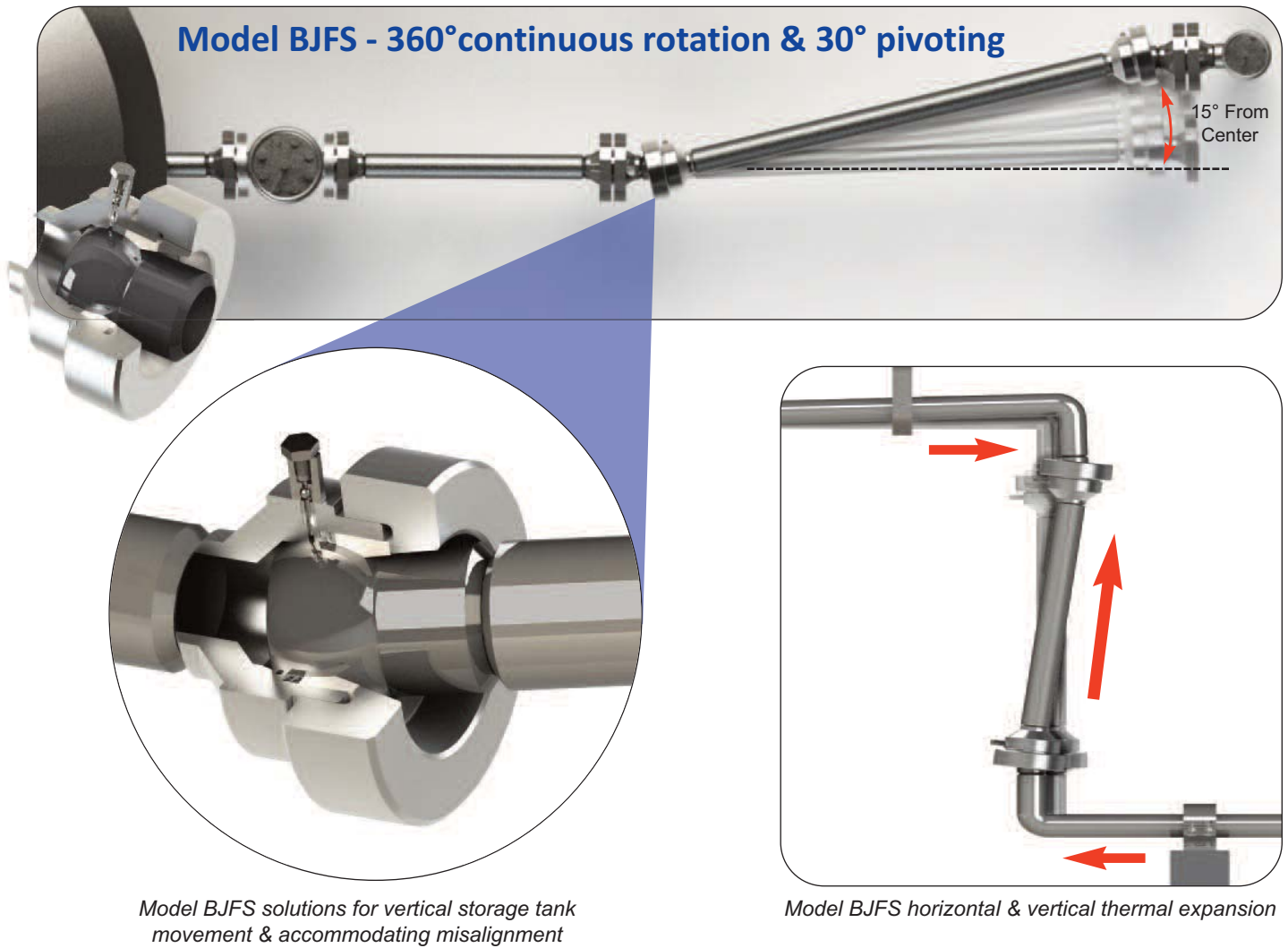
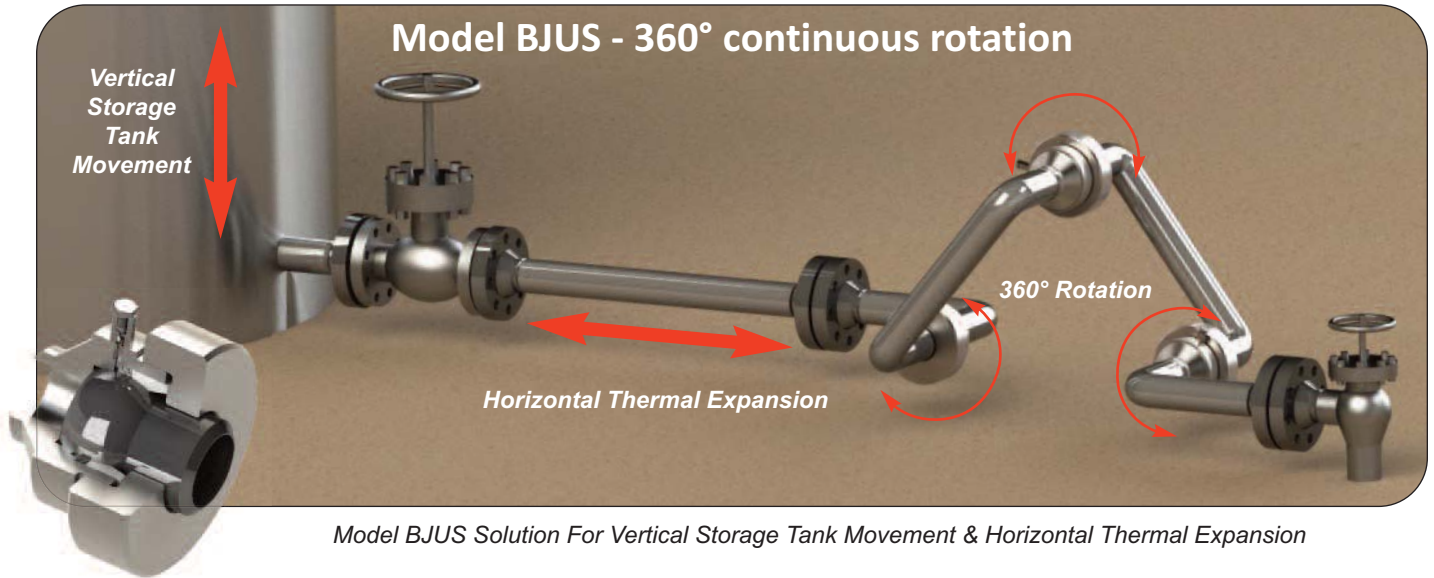

Series BJUS/BJFS Technical Data

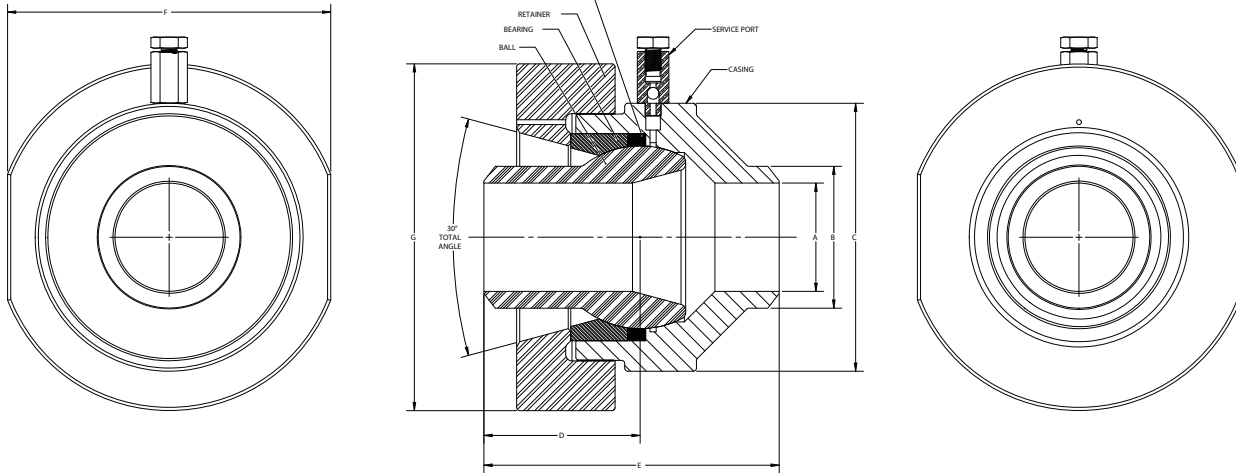

| Nominal Pipe Size inches (DN) | Pressure Class** | PN Pressure Class** (bar) | Approximate Connector Dimensions - inches (mm) | | | | | | Approximate Weight**** lbs (kg) |
|-------------------------------|------------------|---------------------------|--|-------------|------------|-------------|-------------|-------------|---------------------------------|
| | | | B | C | D | E | F | G | |
| 1.5 (40) | 150 to 1500 | 20 to 260 | 1.900 (48) | 5.90 (150) | 3.63 (92) | 6.81 (173) | 6.00 (152) | 7.00 (178) | 30 (14) |
| 2.0 (50) | 150 to 1500 | 20 to 260 | 2.375 (60) | 5.90 (150) | 3.63 (92) | 6.81 (173) | 6.00 (152) | 7.00 (178) | 28 (13) |
| 2.5 (65) | 150 to 1500 | 20 to 260 | 2.875 (73) | 7.20 (183) | 5.00 (127) | 9.56 (243) | 8.25 (210) | 9.00 (229) | 75 (34) |
| 3.0 (80) | 150 to 1500 | 20 to 260 | 3.500 (89) | 7.20 (183) | 5.00 (127) | 9.56 (243) | 8.25 (210) | 9.00 (229) | 70 (32) |
| 4.0 (100) | 150 to 1500 | 20 to 260 | 4.500 (114) | 8.44 (214) | 5.00 (127) | 9.56 (243) | 10.25 (260) | 11.00 (279) | 105 (48) |
| 5.0 (125) | 150 to 1500 | 20 to 260 | 5.563 (141) | 10.90 (277) | 5.72 (145) | 10.88 (276) | 12.00 (305) | 12.75 (324) | 150 (68) |
| 6.0 (150) | 150 to 1500 | 20 to 260 | 6.625 (168) | 10.90 (277) | 5.72 (145) | 10.88 (276) | 12.00 (305) | 12.75 (324) | 150 (68) |
| 8.0 (200) | 150 to 900 | 20 to 150 | 8.625 (219) | 14.50 (368) | 6.50 (165) | 12.00 (305) | 15.98 (406) | 16.50 (419) | 245 (111) |

* Custom schedules, weights, higher pressure ratings and wall thicknesses available upon request.

** Pipe wall thickness may reduce the pressure rating in some cases.

*** A dimension will depend on pressure class

**** Weights may change depending upon pressure class

Accessories

Alignment Connectors

- Available in single or double ball joint configurations to accommodate any amount of misalignment
- No limitations on end connection size or type
- Available in flange x flange or flange x buttweld configurations



Series BJUS/BJFS Technical Data

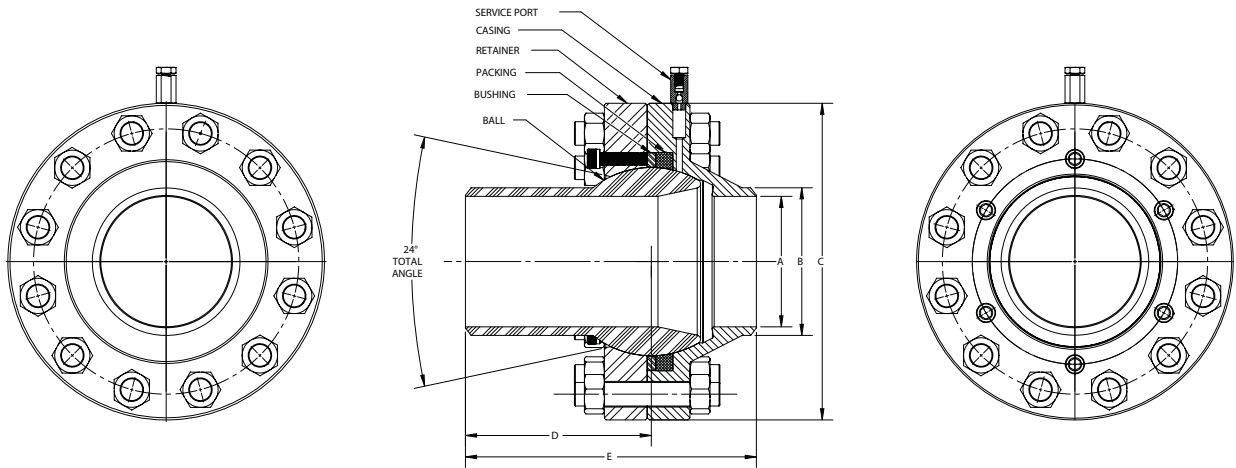

| Nominal Pipe Size inches (DN) | Pressure Class** (psi) | PN Pressure Class** (bar) | Approximate Connector Dimensions - inches (mm) | | | | Approximate Weight**** lbs (kg) |
|----------------------------------|---------------------------|------------------------------|--|--------------|-------------|-------------|------------------------------------|
| | | | B | C | D | E | |
| 8 (200) | 1500 | 260 | 8.625 (219) | 18.75 (476) | 10.86 (276) | 17.00 (432) | 800 (363) |
| 10 (250) | 150 to 300 | 20 to 50 | 10.75 (273) | 19.50 (495) | 8.30 (211) | 16.50 (419) | 455 (206) |
| | 600 | 110 | 10.75 (273) | 20.25 (514) | 8.30 (211) | 17.00 (432) | 680 (308) |
| 12 (300) | 150 to 300 | 20 to 50 | 12.75 (324) | 23.75 (603) | 9.63 (245) | 20.25 (514) | 775 (352) |
| | 600 | 110 | 12.75 (324) | 24.00 (610) | 9.63 (245) | 20.25 (514) | 956 (434) |
| 14 (350) | 150 to 300 | 20 to 50 | 14.00 (356) | 26.00 (660) | 9.00 (229) | 20.50 (521) | 1065 (483) |
| | 600 | 110 | 14.00 (356) | 26.00 (660) | 9.00 (229) | 20.50 (521) | 1282 (582) |
| 16 (400) | 150 to 300 | 20 to 50 | 16.00 (406) | 29.25 (749) | 10.00 (254) | 23.00 (584) | 1609 (730) |
| | 600 | 110 | 16.00 (406) | 29.25 (749) | 10.00 (254) | 23.00 (584) | 1947 (883) |
| 18 (450) | 150 to 300 | 20 to 50 | 18.00 (457) | 33.00 (838) | 11.00 (279) | 25.00 (635) | 1901 (862) |
| | 600 | 110 | 18.00 (457) | 33.00 (838) | 11.00 (279) | 25.00 (635) | 2811 (1275) |
| 20 (500) | 150 to 300 | 20 to 50 | 20.00 (508) | 35.75 (908) | 12.00 (305) | 27.00 (686) | 2674 (1213) |
| | 600 | 110 | 20.00 (508) | 35.75 (908) | 12.00 (305) | 27.00 (686) | 3538 (1605) |
| 24 (600) | 150 to 300 | 20 to 50 | 24.00 (610) | 41.25 (1048) | 14.00 (356) | 31.00 (787) | 4766 (2162) |
| | 600 | 110 | 24.00 (610) | 41.25 (1048) | 14.00 (356) | 31.00 (787) | 6198 (2811) |

* Custom schedules, weights, higher pressure ratings and wall thicknesses available upon request.

** Pipe wall thickness may reduce the pressure rating in some cases.

*** A dimension will depend on pressure class

**** Weights may change depending upon pressure class

Accessories

Expansion Arms

- Geometry optimized to suit pipe movements and space constraints, and to reduce piping stresses
- Fabricated in accordance with material and NDE requirements
- Shipped tested and ready for installation on site



Applications

- Thermal oil extraction processes
- Thermal Expansion / Seismic Movement
- Marine loading piping systems
- Solar energy piping systems
- SAGD (Steam Assisted Gravity Drainage)
- CSS (Cyclic Steam Stimulation)
- SAP (Solvent-aided process)
- THAI (Toe-to-heel air injection)
- Production Platform / Barges
- Caisson Motion / Wellhead Thermal
- Bridge and Compressor Piping
- Flow Line / Jumpers / Fire Protection
- Deck, Barge, Pump Misalignment
- FPSO & Drilling Ships
- Turret
- Deck Motion
- Module Motion
- Flow Line Thermal
- Hull Flex
- Hull Torsion
- Fire Protection
- Wellhead Thermal
- Steam Injection Wells
- Frost Heave
- System Thermal
- Solar Panel Piping Systems
- Tank Settlement / Distribution
- Off Loading, On Loading
- Above Ground / Vaults / Buried
- Safety Relief Valve Vent
- Sub Sea Oil Wells



Oil Wellhead



Steam Injection Well



Sub Sea Oil Well Christmas Tree



Tank Settlement



Solar Energy



Barge Tide Water Movement

Thorburn Quality System

Commercial & Industrial Certification

- ISO 9001:2015
- ASME B31.1, B31.3, CSA B51
- ASME Section VIII, Div 1 "U Stamp"

Nuclear Certifications

- CSA N285.0
- ASME Section III, NCA 4000 NQA-1 "NPT Stamp"
- HAF 604 (China)
- CSA N299.1



Thorburn burst testing capabilities up to 4000 BAR

Installation and Maintenance Guidelines

Receiving Inspection

Thorburn's ball joint swivel pipe connectors should be inspected upon receipt and all damages or shortages should be reported within seven days. Also, check the following:

1. Make sure that the tag displays the project number, design pressure and design temperature. This information is critical.
2. Make sure the locking screw is attached to the ball valve.
3. Make sure ball cannot move by hand.

Storage

Ball joint swivel pipe connectors should be stored indoors prior to installation to maximize preservation of the coating system and prevent particles entering the sealing area.

Installation

The media flow direction can be from either end of the pipe connector except for liquids with suspended solids where the flow direction should be from the ball end to the casing end. In vertical installations, ball joint swivel pipe connectors should be installed with the ball end down to prevent foreign matter from collecting between the neck of the ball and the retainer.

Verify tagging information and confirm that the ball joint materials, pressure, temperature and seals are compatible with the application. Any misalignment should be combined with the thermal movements and the total should not exceed 15° from the center line of the swivel joint. Thorburn's swivel ball joint connectors are delivered pre-assembled with flanges or butt-weld ends, ready for immediate installation.

Do not loosen the ball joint retainer during installation or utilize Thorburn's ball joint swivel pipe connectors as unions. Each pipe connector is factory preset and tested before shipment. Disassembling of the ball joint retainer is not recommended.

Welding the Ball joint to the Piping System

Conventional welding procedures to ASME Section IX may be followed in welding the ball joint swivel pipe connectors to a piping system.

Use caution preheating, welding, or post weld heat treating ball joint swivel pipe connectors into the line. Excessive heating of the sealing area may result in distortion which can cause leakage. Protect the exposed ball surface from weld splatter and prevent dirt, sand and debris from collecting around the neck of the ball. Clean the area as required.

Use clean ceramic wool when welding to ensure that the weld spatter and grinding debris do not enter the sealing area. Debris in the adjoining pipe must also be removed prior to installation of Thorburn ball joint swivel pipe connectors.

Upon completion of the welding, grinding and installation of the ball joint, carefully remove the ceramic wool and thoroughly inspect that no particles are between the ball and the retainer bearing. Clean the area as required.

Field Injection Port

Ball joint swivel pipe connectors come lubricated and will not require lubrication. Please contact Thorburn Flex for specific instructions on when and how to use the field injection port for lubrication.

Maintenance

Ball joint swivel pipe connectors should be inspected after installation to verify that the angular position of the ball is not binding against the retainer inside diameter. It should be inspected again after first pressure cycling to verify angular positioning and ensure the ball joints have not been loosened. After first cycling, the ball joint swivel pipe connector should be inspected regularly during operation and inspections should be recorded.



THORBURN FLEX - Canada
 165 Oneida, Pointe-Claire, Quebec
 Canada, H9R 1A9
 Tel: +1-514-695-8710
 Fax: +1-514-695-1321
 sales@thorburnflex.com
 1-800-363-6613
 (Toll Free North America)



ISCIR Romania | CNCAN Romania | EN 13480-2002 | HAF 604 China | TSG China

How To Order

| Model | Size | Pressure Rating | Ends | End Material | Specify |
|---|--|-----------------|--|---|---|
| BJFS | 64 | 4 | BW | S6 | - |
| BJUS BJFS High temperature Graphoil™ seal packing is standard | 24 = 1 1/2" (DN40) 32 = 2" (DN50) 40 = 2 1/2" (DN65) 48 = 3" (DN80) 64 = 4" (DN100) 80 = 5" (DN125) 96 = 6" (DN150) 128 = 8" (DN200) 160 = 10" (DN250) 192 = 12" (DN300) 224 = 14" (DN350) 256 = 16" (DN400) 288 = 18" (DN450) 320 = 20" (DN500) 384 = 24" (DN600) | | BW = Butt weld SW = Socket weld FL1 = ANSI CL 150 FL2 = ANSI CL 300 FL3 = ANSI CL 400 FL4 = ANSI CL 600 FL5 = ANSI CL 900 FL6 = ANSI CL 1500 FL7 = ANSI CL 2500 FL8 = PN10 FL9 = PN16 FL10 = PN20 FL11 = PN50 FL12 = PN68 FL13 = PN110 FL14 = PN150 FL15 = PN260 FL16 = PN420 | Carbon Steel CS = SA105 CSN = SA105N Stainless Steel S6 = SA182 316SS Duplex (2205) DX = SA276 Super Duplex (2507) DXS = SA479 | X = Specify Non Standard notes. If none, leave blank |

Model BJUS

360° continuous rotation

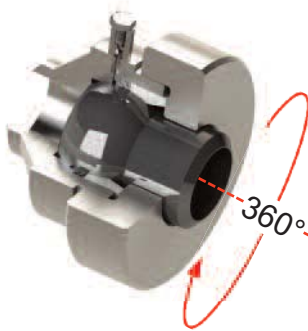

| Code | ASME B16.5 | | ISO 7005 | |
|------|------------|------|----------|--|
| | Class | PSI | BAR* | |
| 1 | 150 | 290 | 20 | |
| 2 | 300 | 750 | 50 | |
| 3 | 400 | 1000 | 68 | |
| 4 | 600 | 1500 | 110 | |
| 5 | 900 | 2250 | 150 | |
| 6 | 1500 | 3750 | 260 | |
| 7 | 2500 | 6250 | 420 | |

* Conforms to Pressure Nominale (PN) ISO 7005
 Pressure rating at temperatures: -28°C to 38°C (-20°F to 100°F)

Model BJFS

360° continuous rotation
 up to 30° angular pivot

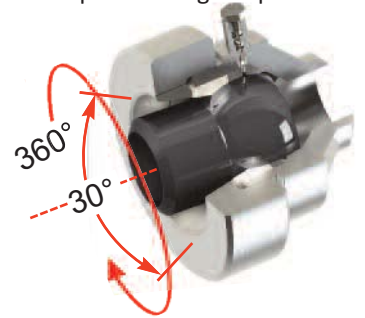

www.thorburnflex.com