

***ThorburnFlex***



**MINIATURE BELLOWS ASSEMBLIES**  
Engineered Solutions For Pipe Motion



[www.thorburnflex.com](http://www.thorburnflex.com)



# ThorburnFlex

Thorburn Flex is an innovative manufacturer of specialized engineered flexible piping systems (i.e. custom hose assemblies and expansion joints). Since 1954, Thorburn’s corporate mission evolution and business philosophy have been customer driven and targeted to select niche applications where Thorburn can achieve clear positions of sustainable technological and market share leadership. Thorburn is committed to a policy of continuous development and research to provide engineered solutions for pipe motion that set the industry standards for quality, safety, environmental protection, durability and value.



European  
Conformity



ISO  
9001



B31.1,  
B31.3



ASME “NPT”  
Sec. III Class 1



ASME “U”  
Sec. VIII Div. 1



N285.0, B51  
CGA CR96-001



97/23/EC  
Module H



UL  
536

ISCIR Romania | CNCAN Romania | EN 13480-2002 | HAF 604 China | TSG China

[www.thorburnflex.com](http://www.thorburnflex.com)



## Table Of Contents

### Miniature Bellows Assemblies

Engineered Solutions For Pipe Motion	04
Thorburn Quality Control System	05
Thorburn In-House Bellows Manufacturing Capabilities	06
What Are Miniature Metallic Bellows?	08
How Thorburn Metallic Bellows Work	09
Thorburn Hydro-formed Bellows	10
Thorburn Miniature Hydro-Formed Bellows Specifications	12
How To Order Thorburn Miniature Metallic Bellows	14
Miniature Metallic Bellows Industrial Applications	15

### Innovative Miniature Bellows Applications

Miniature Bellows For Nuclear Applications	16
Miniature Bellows For Nuclear Service	17
Miniature Bellows For Petrochemical Service	18
Miniature Bellows Seal Valves	19
Miniature Bellows For Wind Energy	20
Miniature Bellows For Solar Energy	21
Miniature Bellows For Aviation & Aerospace Service	22
Miniature Bellows For Medical Service	24
Miniature Bellows For Cryogenics Service	25
Miniature Bellows For Automotive Service	26
Miniature Bellows For Diesel Engine Service	27
Miniature Bellows For Precision Instruments	28
Miniature Bellows For UHV Applications	29

### Technical Data

Thorburn's Metallic Bellows Design Elements	30
Bellows Design Analysis Documentation	31
Thermal Expansion Of Pipe	33
Material Standards Comparison	34
Types Of Corrosion	36
Corrosion Resistance Tables	38

## Engineered Solutions For Pipe Motion



### Design Tools & Capabilities

- Finite Element Analysis (FEA)
- Pipe stress analysis
- CAD & Solidworks
- 3D Modeling
- Mathcad

*Thorburn's design team uses FEA & Solidworks to provide engineered pipe motion solutions*

### Thorburn's Core Competence and Global Presence

Thorburn's core competence is engineered solutions for pipe motion. An integral part of our core competence is Thorburn's metallic bellows technology which is a flexible element that is used to absorb movements and provide seals in piping systems. The movement sources are caused by changes in temperature, pressure, ground settling, vibration and mechanical. Thorburn flex is the only company which possesses a nuclear licence for design and manufacture in the USA, Canada, Europe and China. Thorburn's role as a technological leader provides comprehensive knowledge with the broadest range of expansion joints in the industry. We have developed innovative solutions for flexible seals to transport media, vibration dampening and compensation of thermal and mechanical movements.



### Engineering Capabilities & Experience

Thorburn's design engineering expertise is supported by advanced FEA software that offers powerful and complete solutions for both routine and sophisticated engineering problems. Thorburn's engineers can analyse and provide innovative solutions for pipe motion challenges including dynamic vibration, nonlinear static, linear static, thermal gradient through material wall thickness, acoustic impedance and fatigue using a common model data structure and integrated solver technology.

## Thorburn Quality Control System



Inspecting bellows using an optical comparator to check dimensional accuracy and surface defects

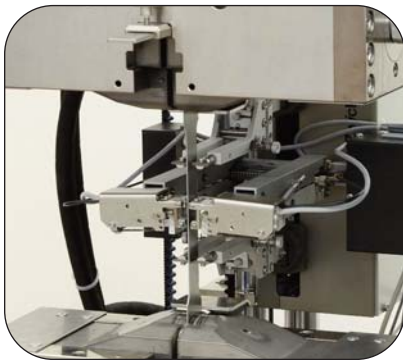

Tensile testing on sheet metal

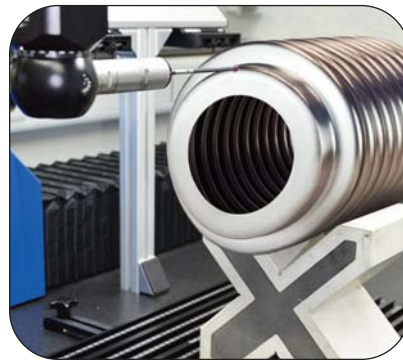

Measuring bellows with CMM Machine

### Quality Certifications For Design & Fabrication

#### Commercial

- ISO 9001

#### Piping & Pressure Vessel

- ASME Section VIII Div 1 ("U" Stamp)
- ASME B31.1, B31.3, B31.5 (USA)
- CSA B.51 (Categories A & D) (Canada)
- EN 14917 PED 2014 | 60 | VE Model H
- TSG (China)

#### Nuclear

- CSA N299.1 (CANDU Nuclear Family)
- ASME Section III NPT, Class 1 (USA)
- CSA N285.0 (Canada)
- HAF 604 (China)
- CNCAN, ISCIR (Romania)

### Destructive & Non-Destructive Testing Capabilities

- Acoustical impedance/noise emission testing
- Large diameter pipe simulating testing
- Radiography, dye penetrant, ultrasonic, magnetic particles
- Burst testing up to 10,000 Bar
- Bellows fatigue & deflection testing
- Seismic and vibration analysis
- Impulse testing up to 680 Bar at 204°C
- Helium mass spectrometer leak testing



Metal bellows cyclic fatigue testing



Helium leak testing metal bellows

## Thorburn In-House Bellows Manufacturing Capabilities

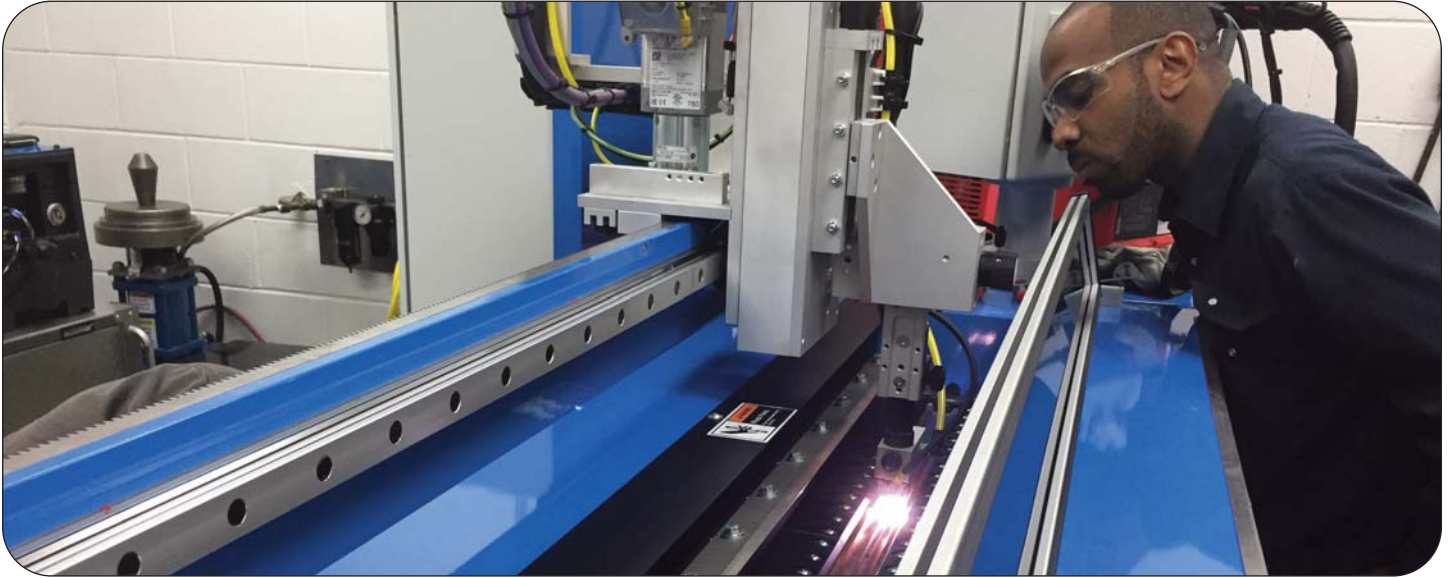

*Thorburn uses robotic fusion seam welding metal foils into tubes with ASME Section II, 2014/68/EU PED materials*

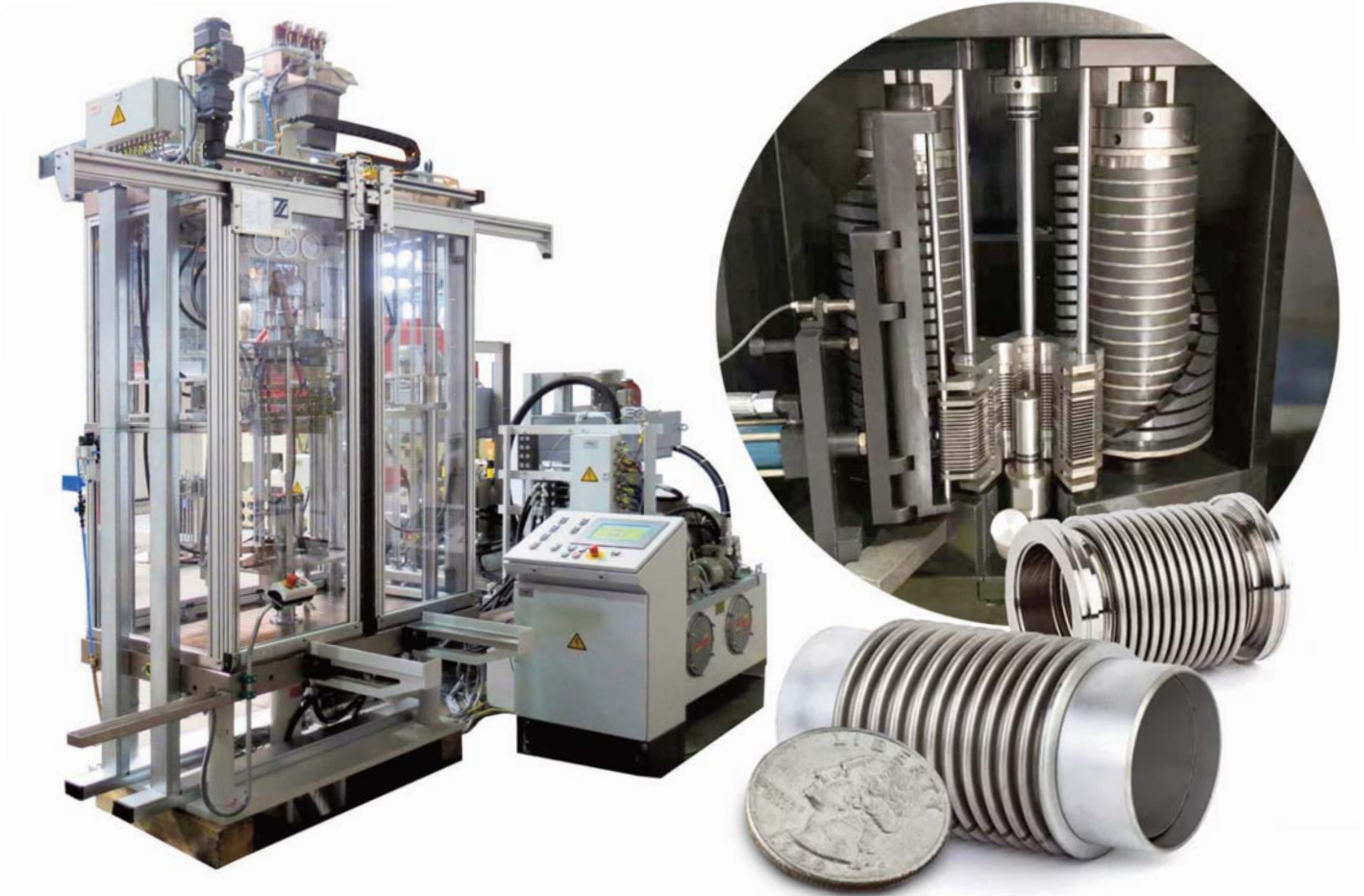

*Thorburn's miniature bellows are hydro-formed with all convolutions simultaneously for optimum precision annular bellows*



*Thorburn's external automatic micro GTAW/PAW robotic welding*

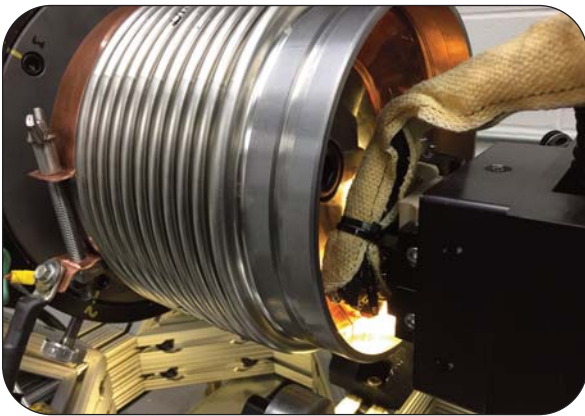

*Close up of Thorburn's automatic circumferential micro GTAW/PAW welding*



*Thorburn's welding operator monitoring the automatic circumferential weld through a remote video camera*

### **NDT/NDE Programs & Design Verification Testing**

- Weld X-Ray to 300KV-5MA / welds dye penetrant to ASME Sec V
- Vacuum testing 760mm (29.9") HG and hydrostatic or nitrogen pressure testing to 1,000 bar (15,000 psi)
- Destructive design verification testing to 4000 bar (60,000 psi)
- Impulse testing to 680 bar (10,000 psi) at 204°C (400°F).
- Burst testing up to 10,000 bar (150,000 psi)
- Pliability fatigue and deflection testing ISO 10380:2012
- Seismic and vibration analysis in acceptance with ASME Sec III
- Helium mass spectrometer leak testing

### **Welding and Fabrication Capabilities**

- Arc, pulse arc, TIG, micro TIG, micro plasma, MIG, core wire, laser
- Tube welding, automated and track welding, automated flame cutting and hydro cutting
- Automated rolls, positioners and turntables
- Automated fitting to end joints welding DN 6mm (1/4") to DN 100mm (4")
- Automated hydro-forming convolutions DN 6mm (1/4") to DN 100mm (4")
- Mechanical forming convolution heights DN 40mm (1 1/2") to DN 100mm (4")

## What Are Miniature Metallic Bellows Assemblies?



Miniature metal bellows are thin walled convoluted cylindrical tubes that are elastic vessels that can compress when you apply pressure to their exterior, or extend when put under a vacuum. When you release the vacuum or pressure, the metal elastic vessel can return to its original shape. Thorburn miniature bellows can be manufactured with diameters as small as 0.25 in (6 mm) that are dynamically flexible which can bend, compress, cycle, and are helium leak-tight. Miniature bellows are hydro-formed which are ideal for dynamic applications where precision, repeatability, reliability and long life capability are critical requirements.

### Seam Welded Tubes

Thorburn miniature bellows can be made from a longitudinally seam welded tube. The seam can be left beaded or it can be further worked by cold rolling by a process called planishing.

### Seamless Tubes

Thorburn miniature bellows can be made from a seamless tube through an extrusion process where the tube is drawn from a solid billet and extruded into a hollow form. The billets are first heated and then formed into oblong circular molds that are hollowed in a piercing mill. While hot, the molds are drawn through a mandrel rod and elongated. The mandrel milling process increases the molds length by twenty times to form a seamless tube shape. Tubing is further shaped through pilgering, a cold rolling or cold drawing process.

### Thorburn Multi-Ply Bellows

Thorburn can manufacture multi-ply tubes which can increase cycle life and lower reaction forces while increasing pressure capacity. The multi-ply tubes act in unison as far as hoop pressure loading is concerned but act individually when cycle life and forces are calculated. Thorburn's miniature bellows can be designed with various convolution heights to simplify installation.

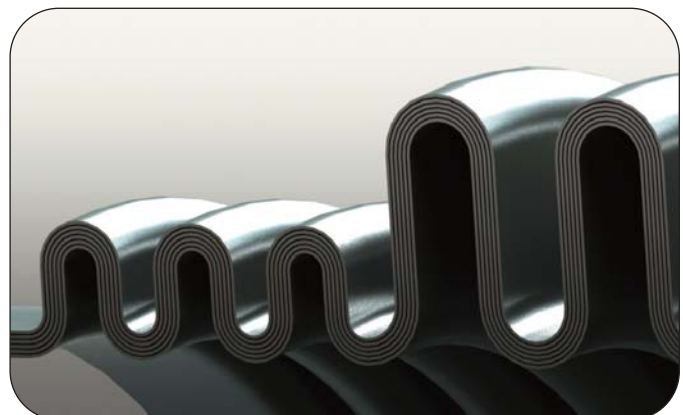

## How Thorburn Miniature Bellows Works

Thorburn's miniature bellows are a flexible seal. The convoluted portion is designed to flex when thermal or mechanical movements occur in the piping system. The number of convolutions depends upon the amount of movement the bellows must accommodate or the force that must be used to accomplish this deflection. There are four basic movements in a piping system that can be applied to a bellows. These movements are Axial, Lateral, Angular and Torsional. Bellows behave like springs in a piping system and when they are compressed, the bellows resist the movement the same as a spring would.



## Metallic Bellows Movement

### Axial Movement

is the change in dimensional length of the bellows from its free length in a direction parallel to its longitudinal axis. Compression is always expressed as negative (-) and extension as positive (+).

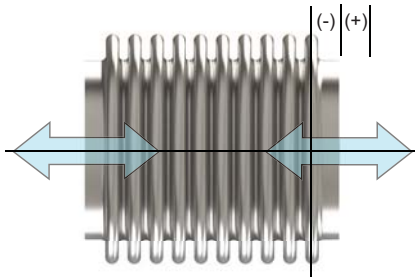

### Angular Movement

is the rotational displacement of the longitudinal axis of the bellows toward a point of rotation. The convolutions at the inner most point are in compression (-) while those furthest away are in extension (+).

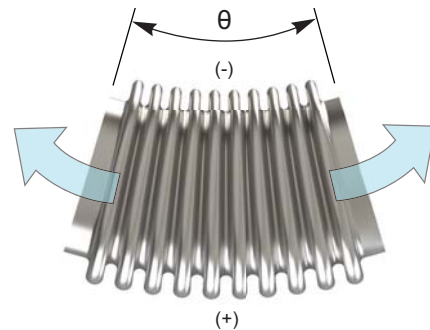

### Lateral Movement

is the relative displacement of one end of the bellows to the other end in a direction perpendicular to its longitudinal axis (shear).

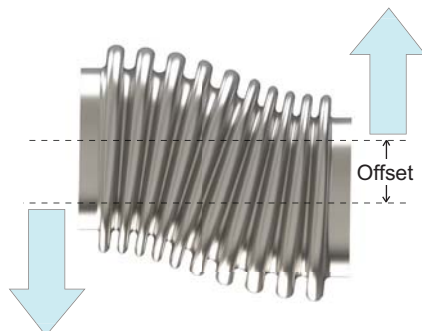

### Torsional Movement

is the rotation about the axis through the center of a bellows (twisting). Torsional movement destabilizes a bellows reducing its ability to contain pressure and absorb movement. Hinge and gimbal attachments are recommended for this type of movement.



## Thorburn Hydro-Formed Bellows

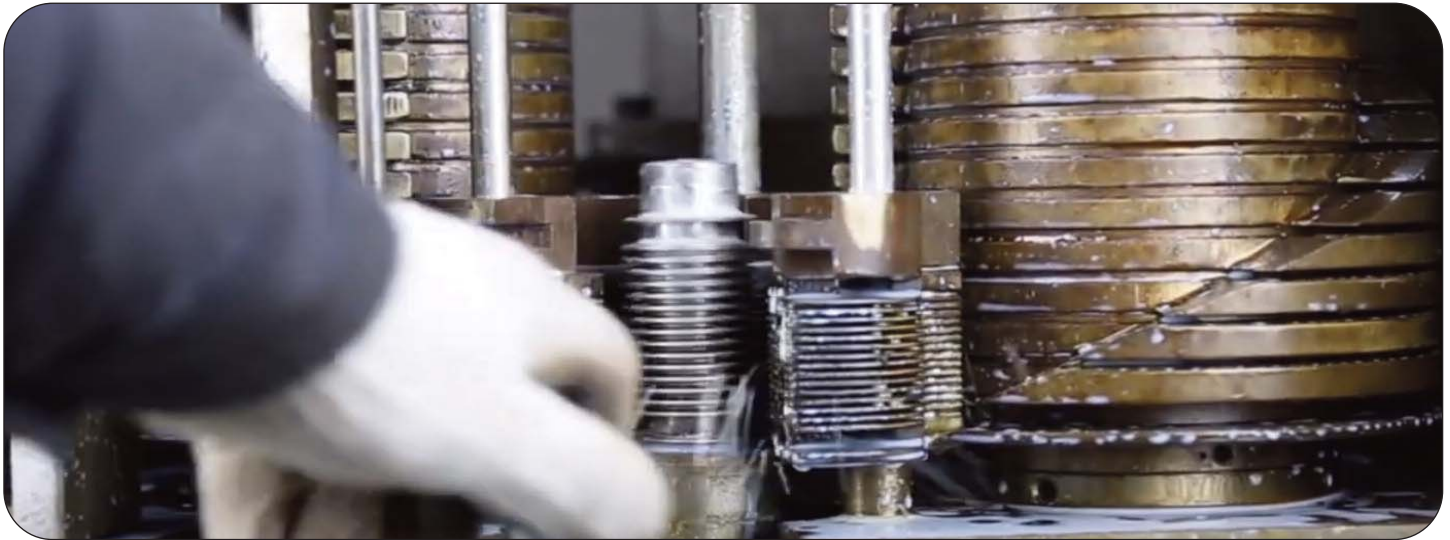

### Hydro-Forming Bellows Process

Thorburn's hydro-forming bellows starts with the creation of a mold in the desired bellows shape. Standard Bellows can be formed using seamless drawn tubing or seam-welded tubing. The precision welded tube is placed inside a movable set of forming plates in a hydraulic corrugating machine. Hydraulic pressure is applied internally and as the tube is expanded outwards between the plates, it is folded longitudinally to produce the bellows. This method is generally effective at producing irregular forms and is effective in bellows production. It is simple to enact this process with the same mold over and over again and produces a consistent high quality bellows.

### Specifications

- Single-ply or Multiple-ply (2, 3, or more)
- ID Size Range: 4mm to 114mm
- Wall Thickness Seamless: 0.05mm to 0.2mm
- Wall Thickness Seam-Welded: 0.1mm to 0.2mm
- 100% Helium Mass Spectrometer leak checked
- Custom Design Capabilities

### Applications

- Pressure switches
- Gauges
- Valves
- Pressure and temperature sensing
- Flexible seals for vacuum interrupters and circuit breakers
- Aneroids for altitude sensing

## Thorburn Hydro-Formed Bellows Standard End Configurations



### Flanged Cuff

Flanged Cuff ends are made by either punching or turning and the most simple and cost effective to produce. It provides a gap-free connection between the bellows and end connector and well suited for use in valve seal bellows with high outside pressure loads.

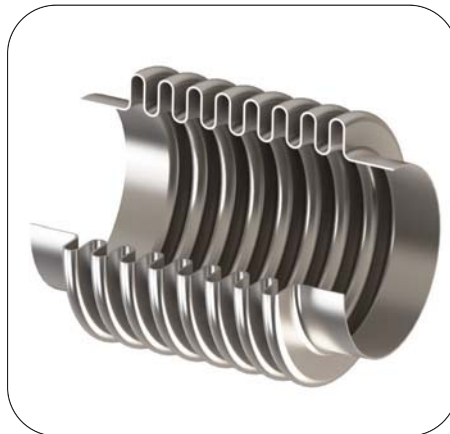

### Straight Cuff

Straight Cuff ends can be made gap-free and most suitable for vacuum seal valves.

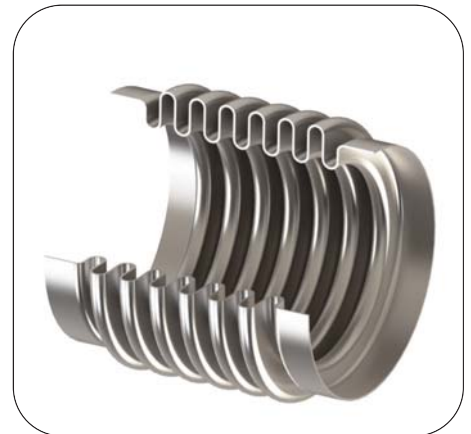

### Expanded Cuff

Expanded Cuff ends can be formed mechanically from a thin wall bellows corrugation or hydraulically from a thick wall bellows. It is well suited for dynamic and highly stressed applications.

## Thorburn Miniature Hydro-Formed Bellows Specifications



C - Flanged Cuff Ends

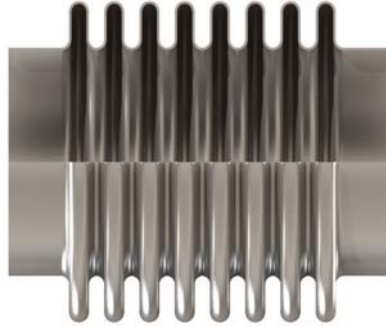

E - Straight Cuff Ends



F - Expanded Cuff Ends

Dimensions														Non-Concurrent Movement (Per Conv. for 10K Cycles)			Nominal Spring Rates (+/- 30%)			
Thorburn Part Number	Nominal Size	Actual Size	Bellows OD	No. of Plies	Nominal Pressure	Effective Area	Maximum Convolutions	Thickness Per Ply	F-End	C-End		E-End		Axial	Angular	Lateral	Axial	Angular	Lateral	
	mm	mm	mm	#	bar	cm <sup>2</sup>	#	mm	mm	I.D.	Length	I.D.	Length							
										mm	mm	mm	mm							
4MBH1	4	4.1	7.0	1	135	0.21	30	0.07	5.5	4.0	5.0	5.5	5.0	0.040	0.70	0.020	260	0.016	15,500	
5MBH1	5	5.3	8.0	1	100	0.36	30	0.10	7.0	5.0	5.0	7.0	5.0	0.065	0.75	0.003	180	0.020	13,500	
8MBH1	8	8.0	13.0	1	21	0.87	30	0.10	11.0	8.0	6.0	11.0	6.0	0.14	1.30	0.004	120	0.028	10,500	
8MBH2	8	8.0	13.0	2	50	0.87	30	0.10	11.0	8.0	6.0	11.0	6.0	0.15	1.20	0.006	245	0.058	15,800	
9MBH1	9	9.0	14.5	1	21	1.30	30	0.10	13.0	9.0	6.0	13.0	6.0	0.21	1.60	0.008	75	0.022	8,500	
9MBH2	9	9.0	14.5	2	41	1.30	30	0.10	13.0	9.0	6.0	13.0	6.0	0.19	1.40	0.008	160	0.048	10,600	
NPS SPECIFICATIONS																				
10MBH1	1/8 NPS	10	10.3	17.0	1	17	1.43	30	0.10	14.5	10.0	6.0	14.5	6.0	0.25	1.70	0.010	60	0.023	5,800
10MBH2		10	10.3	17.0	2	35	1.43	30	0.10	14.5	10.0	6.0	14.5	6.0	0.23	1.60	0.010	120	0.045	8,700
12MBH1	1/4 NPS	12	12.0	20.0	1	12	2.01	30	0.10	18.0	12.0	6.0	18.0	6.0	0.30	1.70	0.011	70	0.050	6,000
12MBH2		12	12.0	20.0	2	25	2.01	30	0.10	18.0	12.0	6.0	18.0	6.0	0.33	1.50	0.011	90	0.045	7,500
14MBH1	1/4 NPS	14	13.72	21.0	1	15	2.63	30	0.10	20.0	18.3	4.0	13.2	6.0	0.28	1.40	0.011	130	0.065	11,200
14MBH2		14	13.72	21.0	2	30	2.63	30	0.10	20.0	18.3	4.0	13.2	6.0	0.25	1.40	0.010	330	0.097	14,100
18MBH1	3/8 NPS	18	17.15	27.0	1	15	4.15	26	0.10	25.0	25.2	3.0	18.0	6.0	0.36	1.30	0.014	185	0.110	12,400
18MBH2		18	17.15	27.0	2	35	4.15	26	0.10	25.0	25.2	3.0	18.0	6.0	0.34	1.10	0.013	310	0.210	20,100
22MBH1	1/2 NPS	22	21.33	34.0	1	11	6.16	26	0.15	30.0	30.2	4.0	22.0	8.0	0.52	1.65	0.015	84	0.014	12,600
22MBH2		22	21.33	34.0	2	25	6.16	26	0.15	30.0	30.2	4.0	22.0	8.0	0.46	1.55	0.015	170	0.600	23,000

# Thorburn Miniature Hydro-Formed Bellows Specifications

Thorburn Part Number		Dimensions													Non-Concurrent Movement (Per Conv. for 10K Cycles)			Nominal Spring Rates (+/- 30%)		
		Nominal Size	Actual Size	Bellows OD	No. of Plies	Nominal Pressure	Effective Area	Maximum Convolutions	Thickness Per Ply	F-End	C-End		E-End		Axial	Angular	Lateral	Axial	Angular	Lateral
		mm	mm	mm	#	bar	cm2	#	mm	mm	I.D.	Length	I.D.	Length	mm	Deg	mm	N/mm	N/Deg	N/mm
26MBH1	3/4 NPS	26	26.67	41.0	1	6	9.10	26	0.15	37.5	-	5.0	27.0	10	0.65	1.60	0.019	52	0.13	9,400
26MBH2		26	26.67	41.0	2	20	9.10	26	0.15	37.5	-	5.0	27.0	10	0.60	1.50	0.015	110	0.25	16,500
34MBH1	1 NPS	34	33.4	50.0	1	6	13.9	26	0.15	47.0	45.3	5.0	34.0	10	0.80	1.70	0.022	46	0.18	10,500
34MBH2		34	33.4	50.0	2	25	13.9	26	0.15	47.0	45.3	5.0	34.0	10	0.63	1.45	0.018	200	0.77	30,000
42MBH1	1 1/4 NPS	42	42.16	60.0	1	8	20.4	26	0.20	55.0	56.3	5.0	42.5	10	0.75	1.50	0.019	90	0.52	19,300
42MBH2		42	42.16	60.0	2	20	20.4	26	0.20	55.0	56.3	5.0	42.5	10	0.75	1.40	0.024	180	1.10	25,400
48MBH1	1 1/2 NPS	48	48.26	66.0	1	8	25.0	18	0.20	62.5	-	5.0	49.0	10	0.80	1.50	0.021	86	0.65	22,500
48MBH2		48	48.26	66.0	2	15	25.0	18	0.20	62.5	-	5.0	49.0	10	0.77	1.40	0.021	178	1.40	39,000
48MBH3		48	48.26	66.0	3	40	25.0	18	0.20	62.5	-	5.0	49.0	10	0.51	0.90	0.017	1240	8.60	184,000
60MBH1	2 NPS	60	60.33	82.0	1	8	39.0	18	0.25	78.0	77.3	5.0	61.0	10	1.10	1.50	0.025	125	1.40	35,000
60MBH2		60	60.33	82.0	2	15	39.0	18	0.25	78.0	77.3	5.0	61.0	10	1.00	1.40	0.025	250	2.50	54,300
60MBH3		60	60.33	82.0	3	30	39.0	18	0.30	78.0	77.3	5.0	61.0	10	0.65	0.90	0.018	700	7.60	147,000
74MBH1	2 1/2 NPS	74	73.05	93.0	1	10	60.0	20	0.25	91.0	-	5.0	74.0	10	1.20	1.30	0.024	120	2.10	47,400
74MBH2		74	73.05	93.0	2	20	60.0	20	0.25	91.0	-	5.0	74.0	10	1.10	1.20	0.023	425	7.40	123,800
74MBH3		74	73.05	93.0	3	30	60.0	20	0.30	91.0	-	5.0	74.0	10	0.90	0.95	0.022	610	11.5	139,000
90MBH1	3 NPS	90	88.90	120.0	1	8	88.0	18	0.30	108.0	-	5.0	90.0	10	1.20	1.10	0.026	180	4.70	63,600
90MBH2		90	88.90	120.0	2	12	88.0	18	0.30	108.0	-	5.0	90.0	10	1.25	1.05	0.024	220	5.70	92,800
90MBH3		90	88.90	120.0	3	18	88.0	18	0.30	108.0	-	5.0	90.0	10	1.00	0.90	0.020	385	10.0	152,800
102MBH1	3 1/2 NPS	102	101.6	130.0	1	8	108.0	18	0.30	124.0	-	5.0	102.0	10	1.50	1.30	0.028	150	4.6	68,500
102MBH2		102	101.6	130.0	2	15	108.0	18	0.30	124.0	-	5.0	102.0	10	1.20	1.00	0.024	465	14.2	183,600
102MBH3		102	101.6	130.0	3	20	108.0	18	0.30	124.0	-	5.0	102.0	10	1.10	0.90	0.024	760	23.2	250,500
114MBH1	4 NPS	114	114.3	150.0	1	10	120.0	14	0.30	126.0	-	5.0	115.0	10	1.00	0.80	0.017	330	11.7	174,000
114MBH2		114	114.3	150.0	2	-	120.0	14	0.30	126.0	-	5.0	115.0	10	0.45	0.40	0.006	1550	52.0	1,270,000
114MBH3		114	114.3	150.0	3	-	120.0	14	0.30	126.0	-	5.0	115.0	10	0.35	0.30	0.005	-	-	-

# How To Order Thorburn Miniature Metallic Bellows

Nominal Size (mm)	Model	Plies (#)	Cons (#)	1st End	2nd End	Pressure (kPa)	Temperature (°C)	Bellows Material	O.A.L. (mm)
<b>8</b>	<b>MBH</b>	<b>2P</b>	<b>8C</b>	<b>C</b>	<b>C</b>	<b>60</b>	<b>+60</b>	<b>B4</b>	<b>125</b>
8 mm	Miniature Hydro-Formed Bellows	2 Plies	8 Cons	Flanged Cuff	Flanged Cuff	60 kPa	+60°C	SS316	125 mm

Thorburn Material Code					ASTM/ASME(S) Material Designation	Material Type
Bellows (B)	Liner (L)	End (E)	Spool (S)	Cover (C)		
B-0	L-0	E-0	S-0	C-0	(S)A36/44W	Carbon Steel
B-1	L-1	E-1	S-1	C-1	(S)A-240	SS304
B-2	L-2	E-2	S-2	C-2	(S)A-240	SS304L
B-3	L-3	E-3	S-3	C-3	(S)A-240	SS316
B-4	L-4	E-4	S-4	C-4	(S)A-240	SS316L
B-5	L-5	E-5	S-5	C-5	(S)A-240	SS321
B-6	L-6	E-6	S-6	C-6	(S)A-240	SS309
B-7	L-7	E-7	S-7	C-7	(S)A-240	SS310
B-8	L-8	E-8	S-8	C-8	(S)B-127	Monel 400
B-9	L-9	E-9	S-9	C-9	(S)B-168	Inconel 600
B-10	L-10	E-10	S-10	C-10	(S)B-443	Inconel 625
B-11	L-11	E-11	S-11	C-11	(S)B-409	Incoloy 800
B-12	L-12	E-12	S-12	C-12	(S)B-424	Incoloy 825
B-14	L-14	E-14	S-14	C-14	(S)B-409	Incoloy 800HT
B-15	L-15	E-15	S-15	C-15	(S)B-162	Nickel 201
B-16	L-16	E-16	S-16	C-16	(S)B-575	Inco C276
B-17	L-17	E-17	S-17	C-17	(S)B-364	Tantalum
B-18	L-18	E-18	S-18	C-18	(S)B-265	Titanium Gr. 1
B-19	L-19	E-19	S-19	C-19	(S)B-551	Zirconium Gr. 702
B-20	L-20	E-20	S-20	C-20	(S)A-285	Carbon Steel
B-21	L-21	E-21	S-21	C-21	(S)A-570	Carbon Steel
B-22	L-22	E-22	S-22	C-22	(S)B-588	Carbon Steel
B-23	L-23	E-23	S-23	C-23	(S)A-606	Corten A
B-24	L-24	E-24	S-24	C-24	(S)A516	Carbon Steel
B-25	L-25	E-25	S-25	C-25	(S)A240	304H
B-26	L-26	E-26	S-26	C-26	(S)A240	316H
B-27	L-27	E-27	S-27	C-27	(S)A240	253MA
B-28	L-28	E-28	S-28	C-28	(S)A240	Duplex SS 2205
B-29	L-29	E-29	S-29	C-29	(S)A240	Super Duplex SS 2507
B-30	L-30	E-30	S-30	C-30	SA204 Gr. B	Carbon Steel
B-31	L-31	E-31	S-31	C-31	SA516-60	Carbon Steel
B-32	L-32	E-32	S-32	C-32	(S)A387	Carbon Steel
B-33	L-33	E-33	S-33	C-33	C51900	Bronze CuSN6 (2.1023)
B-34	L-34	E-34	S-34	C-34	C52100	Bronze CuSN8 (2.1030)
B-X	L-X	E-X	S-X	C-X	-	Special - Specify

**Model:**

**MBH** = Miniature Hydro-formed Bellows

**Number of Convolutions**

- 1C** = 1 Conv. **6C** = 6 Conv.
- 2C** = 2 Conv. **7C** = 7 Conv.
- 3C** = 3 Conv. **8C** = 8 Conv.
- 4C** = 4 Conv. **9C** = 9 Conv.
- 5C** = 5 Conv. **10C** = 10 Conv.

**Number of Plies**

- 1P**= 1 Ply | **2P**= 2 Plies | **3P**= 3 Plies | **4P**= 4 Plies
- 5P**= 5 Plies | **6P**= 6 Plies

**Temperature:** Place (+) or (-) before number (+) above 0°C | (-) below 0°C

**Typical Ends:**



**C** = Flanged Cuff Ends



**E** = Straight Cuff



**F** = Expanded Cuff

**XX** = Special End 1 (Specify)  
**YY** = Special End 2 (Specify)

**Note:** For complex assemblies, Thorburn's drawings will be used as the part number.

**Special notes**

- 1) Use of material codes as a suffix in the catalogue part number designate the bellows (B), liner (L), end connectors (E), spool (S) and Cover (C).
- 2) Special note for flanges and pipes: when forged flanges or scheduled pipe are used, the same nomenclature symbols are used (i.e.: E2 or S6).
- 3) ASTM, ASME "SA" or "SB" materials are standard but other material grades are available upon request.
- 4) All bellows material purchased by Thorburn are "mill annealed" in accordance with "A", "SA" or "SB" specifications. Thorburn does not perform any other heat treating operations before welding, after welding, before forming convolutions or after forming convolutions unless specified by purchaser. Heat treatment of bellows after forming convolutions can lower bellows' spring rate, "squirm" pressure and cycle life. Thorburn will cooperate with purchasers requiring heat treatment after forming to arrive at what effect the heat treatment will have on published bellows data.

**NOTES**

1. Rated cycle life is 2000 cycles for any one movement tabulated minimum per EJMA.
2. To combine axial, lateral or angular movements the sum of each must not exceed 100%.
3. To obtain greater movements or cycle life contact Thorburn.
4. Rated axial movement shown is for both compression or extension.
5. Maximum test pressure: 1-1/2 x rated working pressure.
6. Catalogue pressure ratings are based upon a design temperature range of -20°F to 800°F (-29°C to 427°C). Actual operating temperature should always be specified.
7. For higher pressure temperature, movement and cycle ratings, contact Thorburn with your application details for fast action.

## Miniature Metallic Bellows Industrial Applications

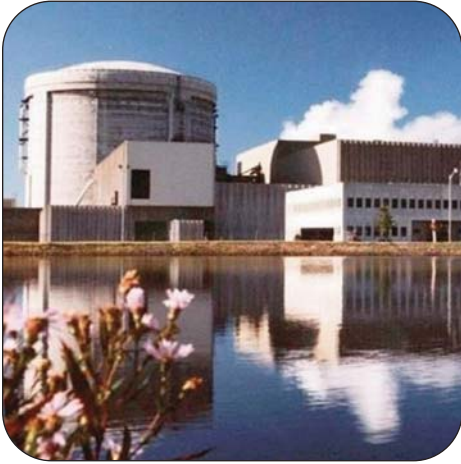

Clean Nuclear Power Generation



Petrochemical Processing



Storage Tank Seal Valves



Wind Energy



Solar Energy



Aviation & Aerospace



Cryogenics



Automotive



Precision Instruments

## Miniature Bellows Assemblies For Nuclear Applications



Bruce Power - The largest nuclear power plant in North America

Thorburn’s metallic bellows expansion joints are an integral part of the primary containment pressure boundary in the Bruce Power PHWR 6000MW nuclear power plant.



### Bruce Power turns to Thorburn Flex during emergency shut-down

Dear Robert,

I wanted to personally thank you for the outstanding support THORBURN FLEX Inc. provided Bruce Power in quickly and efficiently supplying 2 Expansion Bellows required as contingency parts for a pressure boundary steam leak that forced Bruce Power Unit 3 off line on September 24th.

When one of our units is forced off-line, this results in a greater than \$1.5M daily loss in revenue. Our ability to quickly engage dependable, quality suppliers such as THORBURN FLEX Inc. to meet emerging needs such as this is enormously important to our business and our reputation. As we have become accustomed to, your organization quickly responded, pulling out all the stops to supply our requirements in the unbelievably short time of approximately 96 hours.

Please pass on Bruce Power's profound appreciation to all involved for THORBURN FLEX's continuing support to ensure Bruce Power's safe and efficient operations.

Again, sincere thanks.

Harry Hall  
Vice President, Supply Chain | Bruce Power

### Nuclear Certification & Licences (Design & Fabrication)



**USA**

- ASME III NPT Class 1
- NCA 4000 (NQA-1)



**CANADA**

- CSA N285.0
- CSA N299.1
- CRN Available



**EUROPE**

- CNCAN (Romania)
- ISCIR (Romania)



**CHINA**

- H604

### Non-Nuclear Certification & Licences (Design & Fabrication)



**USA**

- ASME Sec. VIII Division 1 "U" Stamp
- ASME B31.1, B31.3



**CANADA**

- CSA B51
- CSA N285.0 Class 6
- ISO 9001
- CRN Available



**EUROPE**

- PED 97/23/EC - Module H



**CHINA**

- TSG

## Miniature Bellows Assemblies For Nuclear Service



*PHWR nuclear power plant in Qinshan, Haiyan County, Jiaxing, Zhejiang province, China*



*Fuel Rod Flask Limit Bellows*

### Thorburn Nuclear Business Unit

Thorburn Flex offers unmatched capabilities and expertise in applications engineering, design development and manufacture of flexible piping systems for PHWR, PWR, BWR nuclear power plants. Operating under a strategy of global presence Thorburn Flex has structured and developed a specific Nuclear Business Unit used to service this niche market sector. Through this business unit, our nuclear components consistently meet and exceed all the quality design requirements of our nuclear reactor business partners.

## Innovative Bellows Assemblies For Nuclear Service

Designed and Manufactured to ASME Section III, Class 2, 3, 4, 6



*Elevator Locking Pin Bellows Assembly*



*Snout Indexing Mechanism Bellows Assembly*



*F/M Head Separator Bellows Assembly*

## Miniature Bellows Assemblies For Petrochemical Service



### Thorburn Metal Bellows For Accumulators

Gas-loaded accumulators are used as energy storage in hydraulic systems consisting of a gas and liquid filled space that are separated by a flexible diaphragm. The more liquid that is pumped into the accumulator, the more the gas volume is compressed and the storage pressure increases. Alternatively, liquid may be withdrawn whereby decreasing the storage pressure. Multi-ply diaphragms or floating pistons are often used as media separators which are not completely resistant to diffusion and are subject to aging. Thorburn thin wall metal bellows provide large working volumes and feature high flexibility and low pressure resistance.

Accumulators with Thorburn's metal bellows function similarly to the compressed gas type, except that the elastic diaphragm or floating piston is replaced by a Thorburn hermetically sealed welded metal bellows. Fluid may be internal or external to the bellows.

### Advantages

- Exceptionally low spring rates, which allows the gas charge to do all the work with little change in pressure from full to empty
- A long stroke that allows efficient usage of the casing volume
- Thorburn's metal bellows can be built to be resistant to overpressure that would crush a bladder-type separator
- The welded Thorburn metal bellows accumulator provides an exceptionally high level of accumulator performance, and can be produced with a broad spectrum of alloys, resulting in a wide range of fluid compatibility.
- Thorburn's metal bellows for accumulators can operate under high pressure and can be built to resist very high or very low temperatures

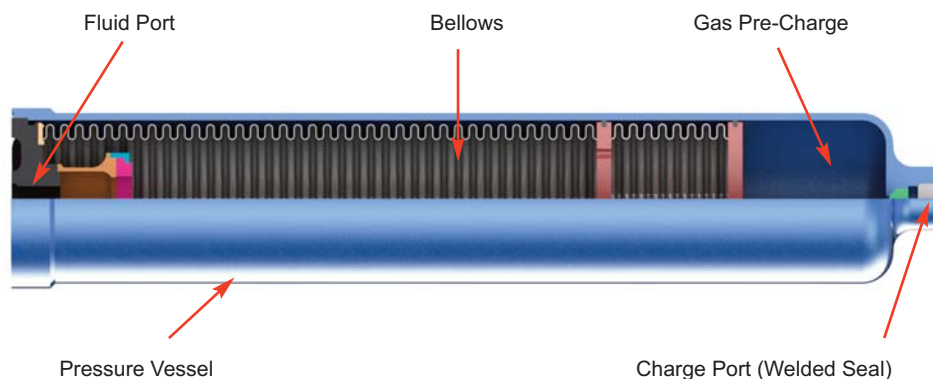

## Miniature Bellows Assemblies For Seal Valves



Leakage at various points in pipelines creates emissions. All such leakage points can be detected using various methods and instruments and should be noted by the plant engineer. Leakage from the Valve gland or stuffing box is normally a concern for the maintenance or plant engineer. This leakage means either a loss of material, pollution to the atmosphere or a Danger for plant employees.

Miniature bellows is a critical component of seal valves. To avoid any twisting of the bellow the valve must have a stem with linear movement only. This can be achieved using a sleeve-nut at the yoke portion of the valve Bonnet. A handwheel is fitted onto the sleeve-nut which effectively transfers a rotary motion of the handwheel into a linear motion in the valve stem.

The bellow cartridge is welded to both the valve bonnet and the valve stem which has a number of convolutions and these convolutions become compressed or expanded depending upon the movement of valve stem. The bellows can be sealed to the valves in two different ways. The bellow can be welded to the valve stem at the top and the valve body on the bottom where the process fluid is

contained inside the bellow. In second method the bellow is welded to the valve stem at the bottom and the body on the top where the process fluid is contained in the annular region between the Valve Bonnet and bellow (from the outside).



### Applications

**Heat Transfer Media** - hot oil is commonly used in industries such as synthetic fibers / POY (Partially Oriented Yarn). However, there is always a risk of fire due to hot oil spillage on highly inflammable chemicals. A bellow seal Valve can stop the leakage.

**Vacuum / ultra high vacuum** - some applications require a vacuum pump to continually extract air from a pipeline. Any conventional valves installed on the pipeline can allow external air to enter the pipeline through the valve stuffing box. Hence the bellow seal valve is the only solution to prevent air from passing through the stuffing box.

**Highly hazardous fluids** - for media such as chlorine, hydrogen, ammonia and phosgene, the bellow seal valve is an ideal design as leakage through the gland is totally eliminated.

**Nuclear Power Plants** - in instances where radiation leakage is to be prevented at all times, the bellow seal Valve is the ultimate choice.

## Miniature Bellows Assemblies For Wind Energy



Wind is a domestic source of energy with an abundant and inexhaustible supply. Wind energy has been harnessed for centuries to propel sailing vessels and turn grist mills and water pumps. Today, wind is used increasingly to generate electricity. A wind turbine turns wind energy into electricity using the aerodynamic force from the rotor blades, which work like an airplane wing or helicopter rotor blade.

Wind turbine pitch, yaw, and brake systems use hydraulic actuation. These hydraulic actuation systems use high-pressure, gas-charged hydraulic accumulators. These accumulators use miniature bellows capsule that forms an internal chamber, which contains the hydraulic fluid and separates it from the precharge gas. The bellows collapses and expands to meet the volume or flow demands of the hydraulic system. During operation, the hydraulic system is at full pressure, and the pressures on both sides of the bellows are balanced. While in hydraulic-shutdown mode, the hydraulic fluid pressure reduces to zero and the bellows capsule fully nests with a differential pressure across the bellows equal to the accumulator gas precharge pressure. The hydraulic shutdown mode places the highest stress on the bellows.

### Wind Turbine Accumulator Bellows

The accumulator bellows consists of a stainless-steel bellows capsule welded to the fixed terminal fitting at one end, and to the movable sweeper fitting at the other end. A Teflon guide attaches to the sweeper to ensure smooth motion of the bellows inside the housing with low friction. The metal bellows accumulator completely eliminates use of elastomeric or wearing seals used in traditional bladder or piston accumulators. Both bladder and piston accumulators experience seal deterioration over time, which can allow charge gas migration into the hydraulic fluid. This adversely affects hydraulic system performance and leads to significant downtime and maintenance. With a metal bellows accumulator, the charge gas is hermetically sealed and so it cannot migrate or leak. Additionally, bladder and piston accumulators are adversely affected by low and high temperature conditions, whereas the welded metal bellows accumulator is unaffected by these temperature extremes. Bellows accumulators have been used in high performance, safety critical hydraulic systems with pressures as high as 8,000 psi (550 Bar) and temperatures from  $-100$  to  $450^{\circ}\text{F}$  ( $-73$  to  $232^{\circ}\text{C}$ ). Because of their all welded stainless steel construction, bellows accumulators are compatible with all hydraulic fluids. Bellows accumulator do not use wearing seals and operates a low friction and its response time is far superior to bladder and piston accumulators. Bellows accumulators can be mounted in any orientation and are suitable for use with all standard hydraulic fluids.

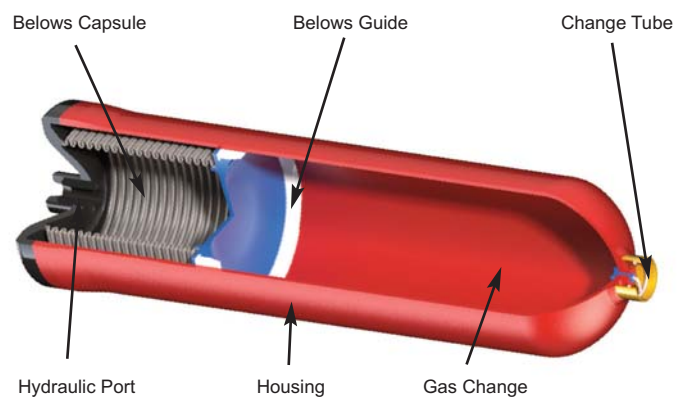

*Cutaway of a piston accumulator with Thorburn's bellows capsule assembly*

## Miniature Bellows Assemblies For Solar Energy

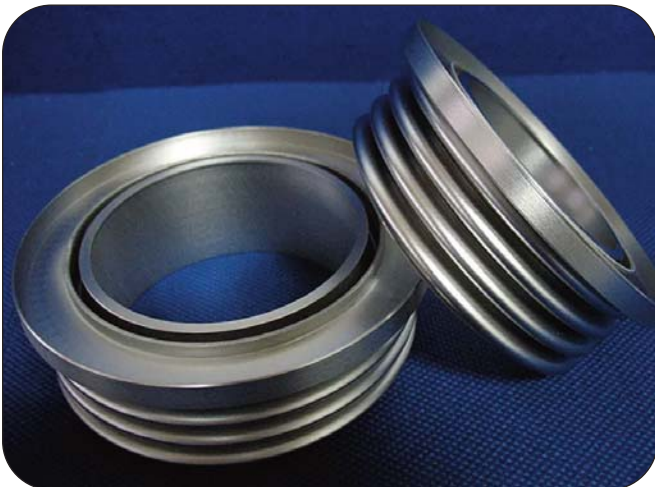

*Solar collector tube metal bellows*

Solar thermal power is becoming an increasingly significant factor in energy generation. The combination of materials with different thermal expansion coefficients results in thermal expansions that must be compensated by a miniature bellows.

Examples include collector tubes for solar power plants. Collector tubes are the heart of parabolic trough power plants. The collector tubes are configured along the focal line of parabolic mirrors. Thermo oil or liquid salt heated by thermal radiation passes through the collector tubes. The heated transfer medium is then used to generate steam for a conventional power plant. The collector itself consists of an outer cladding tube made of coated and highly transparent borosilicate glass and an interior absorber tube made of specially coated steel. The space in between is evacuated to avoid heat loss. Metal bellows at both cuffs of the collectors compensate for the different thermal expansions of glass and steel and ensure a vacuum-tight connection of both tubes.

### Solar Collector Tube Bellows

In solar collector panels in building technology, thermal expansions also have to be compensated at the connection points of the individual collectors. Flexible collector joints are used for this. The illustration left shows a metal bellows design that can be attached to the copper piping of the collectors. Hydraulically formed O-ring grooves and flanges are integrated for attachment purposes at the cuffs of the bellows.

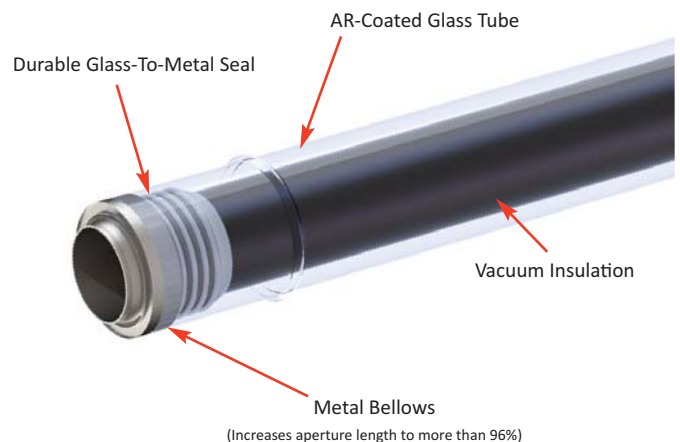

## Miniature Bellows Assemblies For Aviation & Aerospace Service



Thorburn's miniature metal bellows are used in the aerospace industry for fuel lines, exhaust systems, and other applications that require flexibility and durability in extreme environments.



Bellows for trim tank kerosene lines connects the rigid transfer pipe to the flexible trim tank in the horizontal stabilizer and enables continuous drainage and leakage detection for the inner fuel line

Aircraft engine fuel controls require precision bellows for pressure and temperature sensing. These assemblies must tolerate the harsh engine environment, have long cycle life, and provide a precise and repeatable response to changes in pressure or temperature. Metal bellows add mechanical redundancy to electrically based aerospace components to ensure safety and reliability. Many devices as an alternative to digital technology incorporate mechanical bellows in the design, because it is unaffected by electrical signal spikes or electro magnetic pulses. New communications technologies require careful management of signals in high-frequency connections. Gold-plated bellows contacts are used in these devices because they are reliable and exhibit low decibel losses.

### Applications

- Altimeters to help sense altitude changes
- High-Temperature Exhaust Tubing Bellows
- Missile Systems Tubular Components and Assemblies
- Aircraft Hydraulic Accumulator Bellows
- Rocket Ducting Assemblies
- Aircraft fuel valves
- Engine kiss seals
- Toggle switches



Thorburn thin-walled, precision hydro-formed bellows for use in switches as a flexible mechanical seal or as a precision pressure sensing element.

### Miniature Bellows Couplings

Miniature metal bellows are ideal for use as permanent flexible coupling elements for applications in mechanical engineering and precision engineering. The bellows enable direct transmission of force without play of starting and operating torques and compensate for axial, lateral or angular axle offset.

Bellows couplings are used where precise rotation, high speeds, and dynamic motion must be transmitted. They exhibit zero backlash and a high level of torsional stiffness, offering distinct performance advantages. But proper sizing and handling are critical to their successful implementation. Designed for use with shaft couplings, torque limiters, mounts for servo motors, stepper motors and gearboxes.



#### Features

- Maintenance-free and flexible coupling element
- Torsionally-rigid & flexible to bending at the same time
- Symmetrical design for low vibration, high-speed operation
- Ideal transmission of torque
- Long service life

### Jacketed Bellows Assemblies



Jacketed bellows consist of a single bellows with another larger bellows mounted around it forming a chamber between the two bellows. Fluid is circulated between two bellows through inlet and outlet connections attached on the outer pipe on opposite sides of the bellows 180° apart. The media going through the inside bellows is kept under a fixed temperature by passing another liquid on the outside bellows. This facilitates heat exchange through thermal expansion of the pipe.

Jacketed bellows are used where regular insulation is not sufficient to maintain the nominal temperature and when the main fluid flowing through the bellows must be kept at a fixed temperature. Jacketed bellows are highly customized for the exact need and application, as they require a high reliability during the entire service life to avoid the media packing up.

#### Applications

- Pressure switches
- Gauges
- Valves
- Pressure and temperature sensing
- Flexible seals for vacuum interrupters and circuit breakers
- Aneroids for altitude sensing

## Miniature Bellows Assemblies For Medical Service



*Thorburn's miniature metal bellows are used in medical equipment such as robotic actuators, pressure sensors and autoclaves*



*Autoclave machine for sterilization of medical equipment*

Precision miniature metal bellows opens new opportunities for medical equipment, reservoirs, connectivity, and pressure sensor switches. Miniature metal bellows are capable of a very high cycle life and are ideal for service in pharmaceutical and prescription drug manufacturing and clean-room applications.

Thorburn miniature hydro-formed bellows can be used in surgical heat exchangers where human blood flows around the outside of the bellows while saline draws away or restores heat. An autoclave is a machine that uses steam under pressure to kill harmful bacteria, viruses, fungi, and spores on items that are placed inside a pressure vessel. A bellows valve in an autoclave opens when pressure increases during the sterilization process, allowing efficient steam circulation.

### Applications

- Robotic actuators
- Batteries
- Surgical heat exchangers
- Drug delivery
- Autoclaves
- Vacuum pumps and valves
- Precision equipment

## Miniature Bellows Assemblies For Cryogenics Service



Thorburn miniature bellows are used to help regulate temperature and pressure in liquid nitrogen and oxygen tanks, gas pumps, and various other applications. Thorburn's highly useful and effective metal bellows and flexible braided hose can be found in all cryogenic applications such as oil, gas and LNG industries.

### Vacuum Insulated Transfer Piping Systems

Thorburn vacuum insulated transfer piping systems are double-walled pipes that ensure cold liquid gases can safely be transported without excessive warming which can cause the loss of its liquid state. In cryogenic service, the inner pipe gets much colder than the outer pipe and shrinks several millimeters per meter. A Thorburn miniature bellows will absorb the stress caused by the shrinkage of the inner pipe.

### Applications

- Cryogenic Valves
- Self-operated regulators
- Liquid level, differential pressure and flow meters
- Vacuum insulated transfer lines



*Cryogenic mass flow meter*

### Vacuum Insulated Transfer Piping

A Thorburn miniature bellows is mounted between the two spacers to absorb the stress caused by the shrinkage of the inner pipe.



## Miniature Bellows Assemblies For Automotive Service

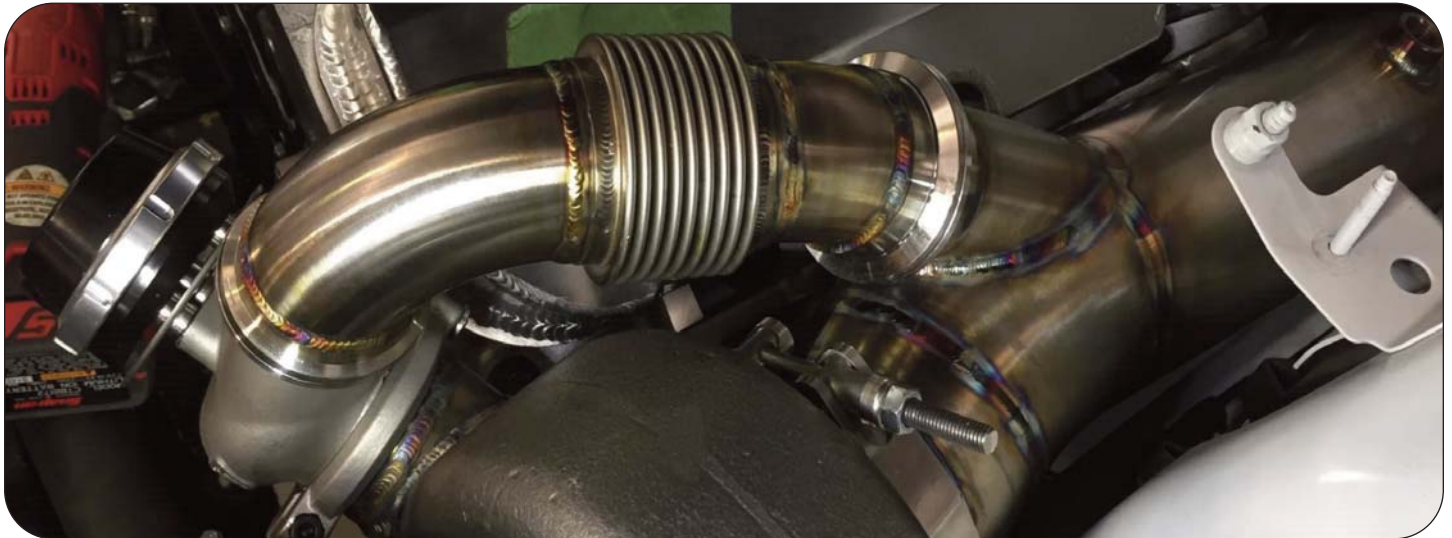

### Piezo\* Fuel Injector

Spray-guided direct injection reduces the fuel consumption of gasoline engines with equal or enhanced engine performance. The requirement for a spray-form combustion consists of highly exact dosages and fine atomization of the injected fuel. These requirements can be met with rapidly switching piezo injectors and injection pressures that exceed 200 bar. The key component of the injector is a piezo actuator, which extends with voltage and thus opens the injection needle. Any type of contact with the fuel would lead to a short-circuit and destroy the piezo actuator. For this reason, a seal which can resist pulsating pressures of up to 300 bar and also allows for over 300 million needle movements is required. Thorburn precision bellows meet these requirements.

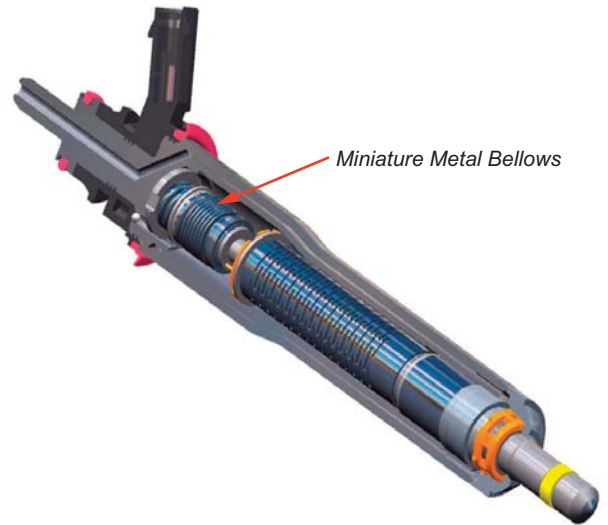

Miniature Metal Bellows

### Fuel Pump

High-pressure pumps are required to supply fuel to direct-injection gasoline engines. These pumps can be designed as one, or multiple-piston pumps with oil-lubricated pistons. Thorburn miniature bellows ensure that the fuel is not contaminated by pump oil. For each piston, a bellows acts as a highly flexible seal and transfer element for pump movements. The bellows are mainly operated in pressure-compensated mode and must execute over 12 billion pump movements over the life of a vehicle.

Bellows component of a Piezo Fuel Injector

### Exhaust Bellows

Thorburn miniature bellows offer customized solutions for vibration and thermal movement challenges found in the exhaust systems installed on all sorts of vehicles and equipment. Exhaust bellows are available in a variety of lengths and end fittings can be customized for various applications to facilitate installation and pressure conditions.



Automotive exhaust pipe metal bellows

\* Piezo is a Greek word meaning "Press" or "Squeeze"

## Miniature Bellows Assemblies For Diesel Engine Service



Thorburn miniature bellows compensate the vibrations and thermal movements developed in the system resulting in a smooth working engine with high efficiency and long life. Thorburn miniature bellows are also a perfect solution for the safety between the engine and the engine charged air line. It is connected between the engine charge airline through the engine cylinder head outlet to the silencer.



*Installed pressure sensor glow plug assembly*

### Pressure Sensor Glow Plug Bellows Systems

To ensure adherence to statutorily prescribed thresholds for NO<sub>x</sub> and CO<sub>2</sub> emissions, an improved regulation of the combustion process in diesel engines is required. By performing an in-situ measurement of the pressure in the combustion chamber, the pressure sensor glow plug provides an important input signal.

The optimized engine control which is achieved with the assistance of the pressure sensor glow plugs allows for the utilization of higher combustion pressures. This is used to increase performance or downsize the engines. In contrast to conventional glow plugs, the plug tip of the pressure sensor glow plugs is mounted for movement. Forces from the pressure in the combustion chamber which is acting on the plug tip is measured with a piezo-resistant sensor.

A Thorburn miniature bellows allows for a friction free transfer of combustion pressure to a piezo sensor. The bellows compensates for heat expansion during the glow operation, and seals the sensor and electronics from the combustion chamber. This application requires the metal bellows to tolerate a high degree of repeated loads in a manner that secures operations. The repeated loads are caused by the resonance initiation of the glow plug tips which are mounted for movement by way of engine vibrations.

## Miniature Bellows Assemblies For Precision Instruments

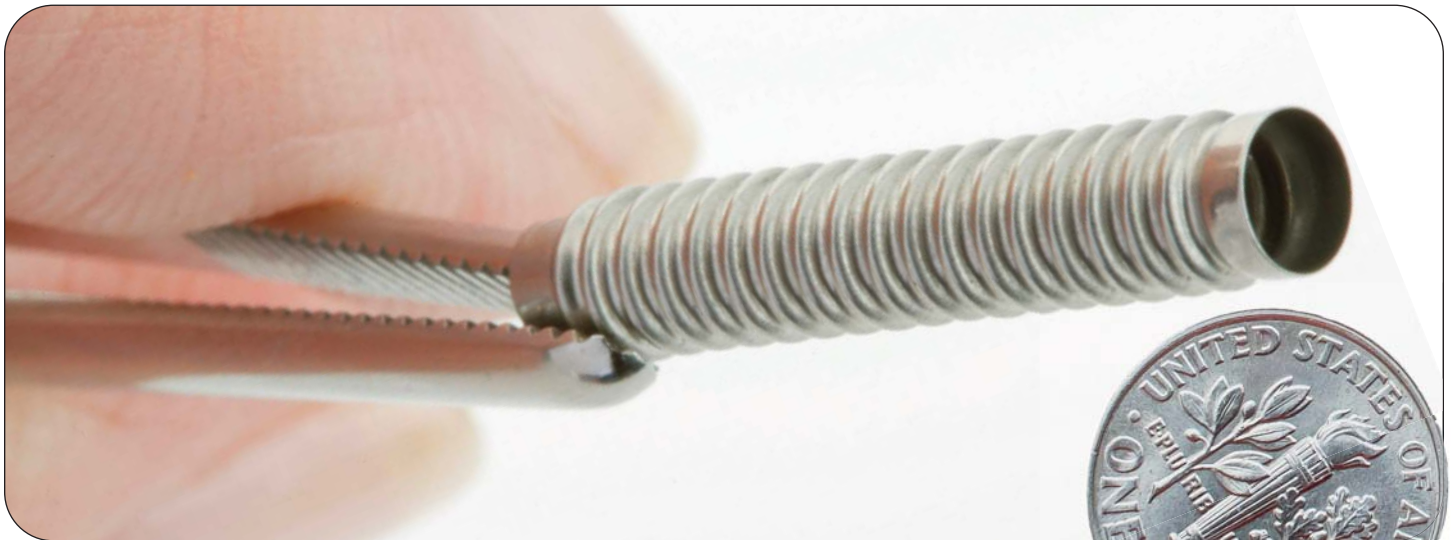

Thorburn miniature bellows assemblies can be used as sensitive elements in pneumatic and electric instruments and can be used as sealing elements in the accessories of vacuum switches, valves and mechanical equipment. They are ideal for use in products where high sensitivity, high pressure resistance, corrosion resistance, reliable performance and long service life are required.

### Applications

- Actuators
- Connectors
- Feed-throughs
- Leak detectors
- Sensors
- Wafer handlers
- Pedestal lift assemblies
- Gate valves



### Bellows For Pressure Sensor

Thorburn miniature bellows for pressure sensors are made of a sealed chamber that contains a miniature metal bellows that is compressed when the sensor is manufactured. When pressure is applied to the inner or outer end of these bellows, the bellows will expand or contract. One end of the bellows connected to a linkage assembly.

Pressure is applied on the closed end which is mobile while the open end does not move. Once the bellows and the assembly move, electrical signals are produced to indicate pressure changes. Bellows pressure sensors are suited for low to medium pressure applications, rather than high pressure.

Thorburn miniature bellows are also used as a differential pressure sensor. In this application two bellows are mounted in a housing where the movement of each bellows oppose the other. This will cause the overall travel of the two bellows to be equal to the difference of pressure that is applied to them.

## Miniature Bellows Assemblies For Vacuum Applications

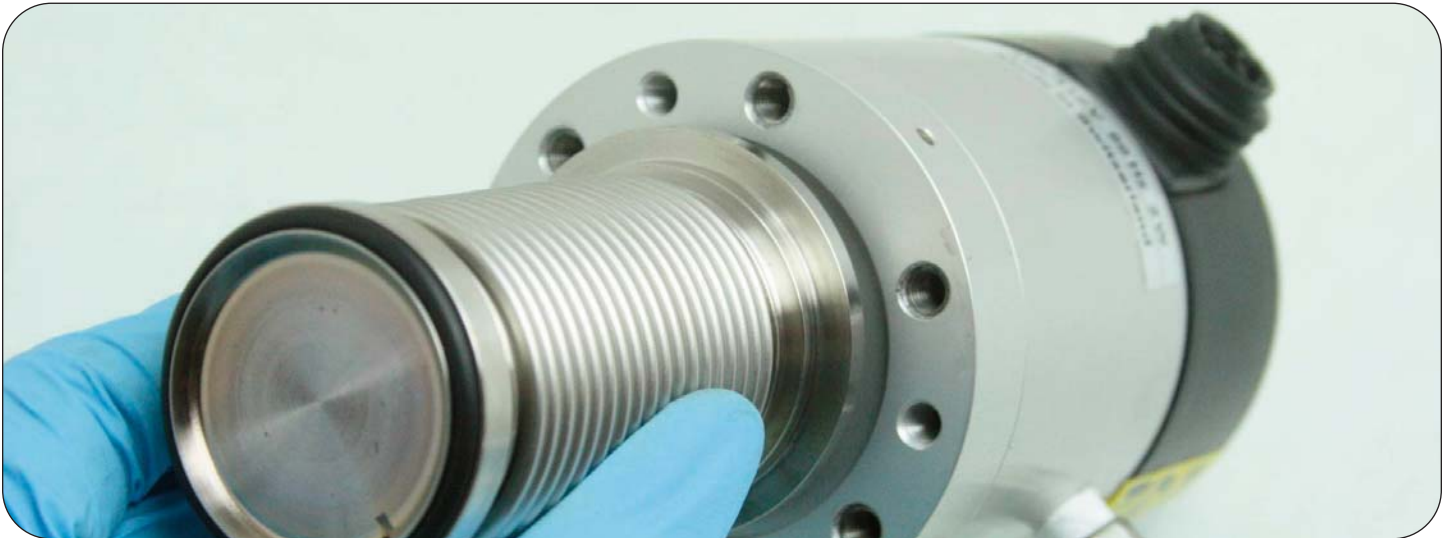

Thorburn vacuum bellows are durable, bendable tubes which are used in the assembly of frontline vacuum plumbing and process systems to pump negative pressure and can only pass gas. The flexible metal bellows allow for movement and misalignment on fixed vacuum piping. Compression and expansion rates are typically 5-10% of the flexible length and is designed to reduce vibration during use and has passed a helium leak test for safety. Thorburn bellows are unsheathed and butt welded for added durability and is resistant to heat and corrosion offering a superior alternative to thick wall PVC vacuum hoses.



*Vacuum Corrugated Bellows Pipe Tubes*

### Applications

- **Semiconductor Industry** vacuum sealing
- **VAT Pneumatic Bellows Actuators** for sealing high vacuum flanges.
- **Freeze Dryers** which conduct lyophilization (cryodesiccation) in vacuum environments with high purity standards.
- **Compressors** can utilize hermetic bellows valves to eliminate leakage past dynamic seals. Compressors can also use valve stem seals when there is a need to hermetically contain the shaft while allowing for axial shaft movement.
- **Volume Compensators** bellows devices have been used to prevent cavitation in when the system's positive pressure must be maintained during any volume fluctuations.
- **Bellows Sealed Linear feed-throughs** are standard positioning devices used to allow movements in the vacuum ranging from coarse to high precision.



*Bellows Sealed Linear feed-through*

## Thorburn's Metallic Bellows Design Elements

### Pressure Thrust

The spring represents the axial spring rate of the bellows. The hydraulic piston represents the effect of the pressure thrust which the expansion joint can exert on the piping anchors or pressure thrust restraints (hinges, Gimbals, tie rods) which may be part of the expansion joint assembly. The area of the hydraulic cylinder would be the effective area of the bellows. Force on equipment or adjacent piping anchors "F" = (the effective area of the bellows) x (the working pressure) + (the spring rate of the bellows) x (the stroke of the bellows). The pressure thrust force would equal (the working pressure) x (the bellows effective area). The pressure thrust force is typically much higher than the spring force. Expansion joints designed for lateral offset or for angular motion are more complicated to model accurately. However, the effect of pressure thrust is the same.

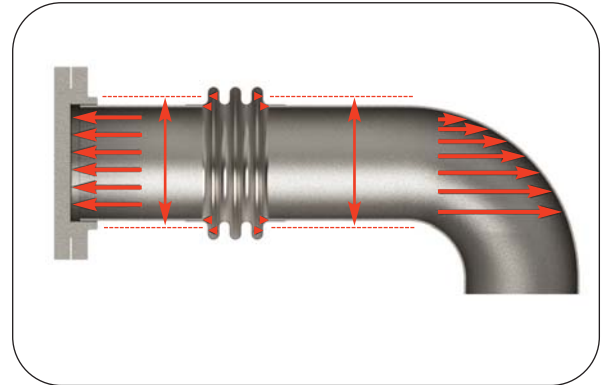

Working pressure acting on the effective area of the bellows is larger than the pipe diameter

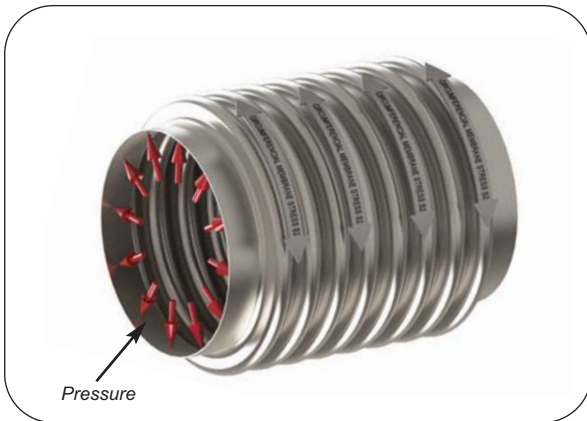

### Circumferential Membrane Stress Due to Pressure $S_2$

The ability of a bellows to carry pressure is measured primarily by hoop stress or  $S_2$  from the standards of the Expansion Joint Manufacturers Association (EJMA).  $S_2$  is the stress which runs circumferentially around the bellows due to the pressure difference between the inside and the outside of the bellows. Hoop stress is what holds a bellows together like the hoops on a barrel. This stress must be held to a code stress level. The user should specify the code to be used.

### Meridional Membrane Stress Due to Pressure $S_4$

The bellows ability to carry pressure is also limited by bulge stress or EJMA stress  $S_4$ . This is a stress which runs longitudinal to the bellows center line. More specifically, it is located in the bellows' side wall and it is a measure of the tendency of the bellows' convolutions to become less U-shaped and more spherical. The value of ( $S_3 + S_4$ ) must be lower than the allowable stress of the bellows' material multiplied by material strength factor which is equal to 3.0 for bellows in the as formed condition (with cold work) and 1.5 bellows in the annealed condition (without cold work). Accommodating a requirement for annealing will often result in the addition of reinforcing rings or a much heavier bellows material and more convolutions. It is Thorburn's standard to not anneal bellows after forming to take advantage of the added performance that is imparted to a bellows through cold work.

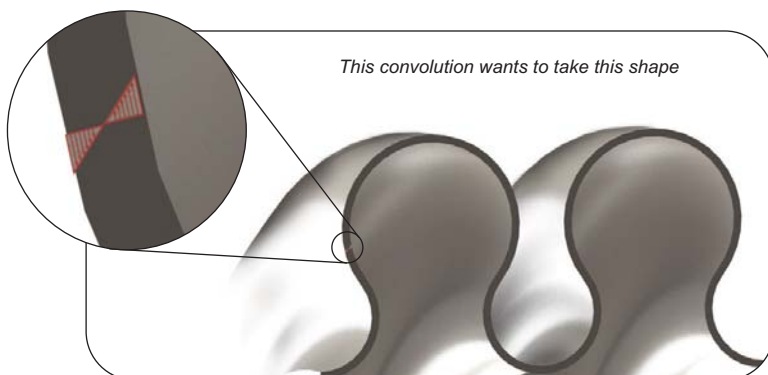

This convolution wants to take this shape

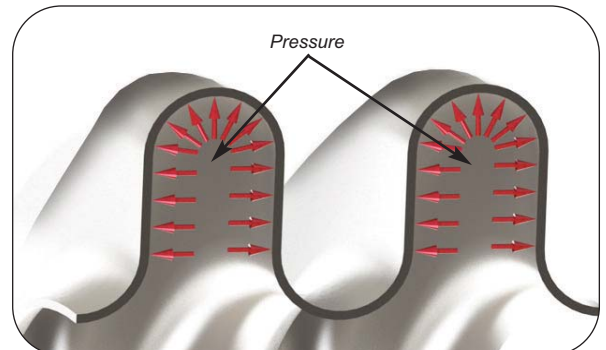

# Thorburn’s Metallic Bellows Design Elements

## Bellows Stability

Excessive internal pressure may cause a bellows to become unstable and squirm. Squirm is detrimental to bellows performance in that it can greatly reduce both fatigue life and pressure capacity. The two most common forms are column squirm and in-plane squirm. Column squirm is defined as a gross lateral shift of the center section of the bellows. It results in curvature of the bellows centerline. This condition is most associated with bellows which have a relatively large length-to-diameter ratio and is analogous to the buckling of a column under compressive load. In-plane squirm is defined as a shift or rotation of the plane of one or more convolutions such that the plane of these convolutions is no longer perpendicular to the axis of the bellows. It is characterized by tilting or warping of one or more convolutions. This condition is predominantly associated with high meridional bending stress and the formation of plastic hinges at the root and crest of the convolutions. It is most common in bellows which have a relatively small length-to-diameter ratio.



*In-plane instability | Column instability*



*Convolution shape before deflecting. When the bellows compresses, the side walls bend to shorten the bellows*

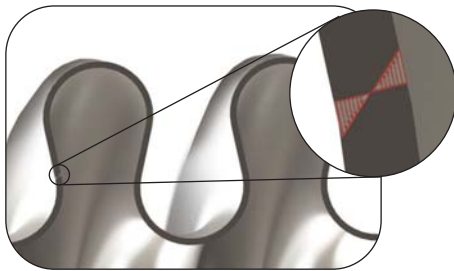

*Convolution shape after deflecting*

## Meridional Bending Stress Due To Deflection $S_6$

When a bellows deflects, the motion is absorbed by deformation of the side walls of each convolution. The associated stress caused by this motion is the deflection stress or EJMA stress  $S_6$ . This stress runs longitudinal to the bellows' center line. The maximum value of  $S_6$  is located in the side wall of each convolution near the crest or root.

Expansion joints are designed to operate with a value of  $S_6$  which far exceeds the yield strength of the bellows material. This means that most expansion joints will take a permanent set at the rated axial or lateral motions. They are rarely designed to be elastic. This also means that the bellows will eventually fatigue after a finite number of movement cycles. It is important to specify a realistic cycle life as a design consideration when ordering an expansion joint. An overly conservative cycle life requirement can result in a bellows design that is so long and soft that it is subject to squirm failure.

## Design Variables As They Affect Metallic Bellows Dynamics

Variation	Stress EJMA S2	Stress EJMA S4	Deflection Stress EJMA S6	Column Squirm Pressure	In-Plane Squirm	Cycle Life	Rated Axial	Rated Lateral	Rated Angular	Axial Spring Rate	Lateral Spring Rate	Angular Spring Rate	Pressure Thrust
Thicker Material	- (1)	- (2)	+ (1)	+ (3)	+ (2)	-	-	-	-	+ (3)	+ (3)	+ (3)	S
Thinner Material	+ (1)	+ (2)	- (1)	- (3)	- (2)	+	+	+	+	- (3)	- (3)	- (3)	S
Higher Convolute	- (1)	+ (2)	- (2)	- (3)	- (2)	+	+	+	+	- (3)	- (3)	- (3)	+
Lower Convolute	- (1)	- (2)	+ (2)	- (3)	+ (2)	-	-	-	-	+ (3)	+ (3)	+ (3)	-
Smaller Pitch	- (1)	+	-	-	-	+	+	+	+	-	-	-	S
Larger Pitch	+ (1)	-	+	+	-	-	-	-	-	+	+	+	S
More Plies	-	-	S	+	-	S	S	S	S	+	+	+	S
Fewer Plies	+	+	S	-	-	S	S	S	S	-	-	-	S
Larger Diameter	+ (1)	S	S	+	-	S	S	-	-	+	+	+	+
Smaller Diameter	+ (1)	S	S	-	-	S	S	+	+	-	-	-	-
More Convolutions	S	S	-	-	-	+	+	+	+	-	-	-	S
Fewer Convolutions	S	S	+	+	-	-	-	-	-	+	+	+	S

**Legend:** + : Increase - : Decrease S: Same (#): Indicates how steeply the variation affects the design variable, i.e., (1) means the change is linear; (2) means the design variable changes by the square of the variable; (3) means the design variable changes by the cube of the variable.

# Bellows Design Analysis Documentation

All custom bellows designs should be documented to prove that the design has been analyzed to the proper code, the design is safe and mechanically stable, the cycle life is in accordance with the specification requirements and the important stress values have been satisfied. Thorburn bellows design analysis shows all the critical information in a summary format. This paper is offered to help a customer interpret the information that is shown on Thorburn's bellows design analysis so the information is more meaningful.

Customer: Project:	File_No := ""	Tag := ""	Qty := 1
INPUT DATA			
Nominal Pipe Size	D := 28-mm	Bellows mat. code	Mat <sub>b</sub> := 5
Design pressure	P := 0.5MPa	Number of bellows	N <sub>b</sub> := 1
Design temp. (°F)	Temp := 446 °F	Spool pipe length	L <sub>s</sub> := 0-mm
Bellows inside diameter	D <sub>b</sub> = 28-mm	Spool pipe thickness	t <sub>s</sub> := 0-mm
Number of cons.	N <sub>c</sub> := 10	Pipe end thickness	t <sub>e</sub> := 0-mm
Thickness of one ply	t := 0.2mm	Collar thickness	t <sub>c</sub> := 0mm
Number of plies	n := 2	Collar length	L <sub>c</sub> := 0-mm
Convolution height	w <sub>c</sub> := 5.5-mm	Bellows neck length	L <sub>r</sub> := 6-mm
Convolution pitch	q <sub>c</sub> := 5.5mm	Spring rate factor	SR := 1.7
Axial (- comp. + ext.)	x := -10mm	Code (10,311,313,8)	Code := 10
Lateral deflection	x <sub>l</sub> := 0mm	Fluid density	ρ <sub>m</sub> := 1.0·kg·L <sup>-1</sup>
Angular rotation	θ := 0-deg	Flow velocity	v <sub>1</sub> := 1m·sec <sup>-1</sup>
Torsional rotation	φ := 0-deg	Factor for flow media	K <sub>f</sub> := 1
Angular rot. preset	θ <sub>p</sub> := 0-deg		
Cold axial preset	x <sub>p</sub> := 0mm		
Cold lateral preset	x <sub>lp</sub> := 0-mm		
		Reinforcement	Type := 0 (0=Unrein, 1=Reinf)
		Reinf. ring type	RR := 1 (0=Integral,1=Bolt)
		Reinf. ring mat. code	Mat <sub>r</sub> := 2
		Collar mat. code	Mat <sub>c</sub> := 2
		Liner mat. code	Mat <sub>l</sub> := 2
		Bolt mat. code	Mat <sub>b</sub> := 24
		Width RR rib	W <sub>rr</sub> := 0-mm
		Thk RR rib	t <sub>rr</sub> := 0-mm
		RR Bolt Diam	D <sub>r</sub> := 14-mm
		Bolt length	L <sub>f</sub> := 125-mm
		Bolt thread pitch	T <sub>pi</sub> := 2·mm <sup>-1</sup>
		No. of gussets per tangent collar	n <sub>g</sub> := 10
		Below actual Yield	S <sub>y<sub>mb</sub></sub> := 206.85-MPa
CALCULATION			
	Temp_C = 230 °C	P = 500-kPa	Tool width T <sub>w</sub> = 0.093-in
	Max_Temp = 1500 °F	P = 73-psi	Flow_Rate = 3·m <sup>3</sup> ·hr <sup>-1</sup>
Bellows_Mat = "SS T321, SA-240, S32100"			
<b>Material Properties</b>	<b>Room Temp.</b>	<b>Design Temp.</b>	<b>Bellows Dimensions</b>
Allowable stress	Sa <sub>0b</sub> = 138-MPa	Sa <sub>b</sub> = 136-MPa	-Bellows eff. area A <sub>e</sub> = 9·cm <sup>2</sup>
Yield strength	Sy <sub>0b</sub> = 207-MPa	Sy <sub>b</sub> = 154-MPa	-Bellows free length L <sub>b</sub> = 55-mm
Moduli of elasticity	E <sub>0b</sub> = 195.12 × 10 <sup>3</sup> ·MPa	E <sub>b</sub> = 180.44 × 10 <sup>3</sup> ·MPa	-Univ E.J. free length L <sub>u</sub> = 55-mm
Convolution factors:	C <sub>d</sub> = 1.8563 C <sub>f</sub> = 1.2352	C <sub>p</sub> = 0.5491	-Bellows weight W <sub>b</sub> = 0·kg
			-Movement/conv. e <sub>r</sub> = 1·mm
			-OD reinf ring od <sub>r</sub> = 0-mm
<b>Stress Values Eq C-4.2 of E.J.M.A.</b>			
S <sub>1</sub> = Tangent circumf. membrane stress due to press.	S <sub>1</sub> = 18-MPa		<b>Stress Verification</b> =1 when is "TRUE"
S <sub>11</sub> = Collar circumf. membrane stress due to press.	S <sub>11</sub> = 0-MPa		S <sub>1</sub> ≤ C <sub>wb</sub> ·Sa <sub>b</sub> = 1 V <sub>1</sub> = "Pass"
S <sub>12</sub> = Collar circumf. bending stress due to press.	S <sub>12</sub> = 0-MPa		S <sub>2</sub> ≤ C <sub>wb</sub> ·Sa <sub>b</sub> = 1 V <sub>2</sub> = "Pass"
S <sub>2</sub> = Circumf. membrane stress due to pressure	S <sub>2</sub> = 9-MPa		S <sub>3</sub> + S <sub>4</sub> ≤ C <sub>m</sub> ·Sa <sub>b</sub> = 1 V <sub>34</sub> = "Pass"
S <sub>21</sub> = Reinf. ring circumferential stress due to press.	S <sub>21</sub> = 0-MPa		S <sub>11</sub> ≤ C <sub>wc</sub> ·Sa <sub>c</sub> = 1 V <sub>11</sub> = "Pass"
S <sub>22</sub> = Fastener Membrane stress due to pressure	S <sub>22</sub> = 0-MPa		<b>For reinforced only</b>
S <sub>3</sub> = Meridional memb. stress due to pressure	S <sub>3</sub> = 4-MPa		S <sub>11</sub> + S <sub>12</sub> ≤ K <sub>s</sub> ·C <sub>wc</sub> ·W <sub>r</sub> ·Sa <sub>c</sub> = 1 V <sub>1112</sub> = "NA"
S <sub>4</sub> = Meridional bending stress due to press.	S <sub>4</sub> = 63-MPa		S <sub>21</sub> ≤ C <sub>wr</sub> ·W <sub>r</sub> ·Sa <sub>r</sub> = 1 V <sub>21</sub> = "NA"
S <sub>5</sub> = Meridional membrane stress due to defl.	S <sub>5</sub> = 16-MPa		S <sub>22</sub> ≤ Sa <sub>f</sub> = 1 V <sub>22</sub> = "NA"
S <sub>6</sub> = Meridional bending stress due to deflection	S <sub>6</sub> = 1053-MPa		
S <sub>7</sub> = Total stress range for design conditions	S <sub>7</sub> = 1115-MPa		
<b>Spring Rates</b>			
-Axial f <sub>wa</sub> = 41·N·mm <sup>-1</sup>			
-Lateral f <sub>wl</sub> = 35·N·mm <sup>-1</sup>			
-Angular f <sub>wθ</sub> = 0·N·m·deg <sup>-1</sup>			
-Torsional f <sub>wφ</sub> = 519 × 10 <sup>0</sup> ·lbf·in·deg <sup>-1</sup>			
-Max. velocity for flow induced vibration (no liner)			
Liner <sub>chk</sub> = "Liner Required"			
<b>Life Expectancy (cycles) for applicable Code</b>			
Nc = 16093 EJMA 10th Ed.			
Nc_B313 = 4050 ASME B31.3			
Nc_VIII = 1760 ASME Sect. VIII, App. 26			
Nc_III = 713 ASME Sect. III, Div.1			
		<b>Reaction Forces</b>	
		F <sub>a</sub> = -407-N	Psc Column squirm Psc = 1180-kPa V_Psc = "Pass"
		V <sub>l</sub> = 0-N	Psi In-plane squirm Psi = 2374-kPa V_Psi = "Pass"
		M <sub>θ</sub> = 0-N·m	
		M <sub>φ</sub> = 0 × 10 <sup>0</sup> ·N·m	
		v <sub>alw</sub> = 0.4·m·s <sup>-1</sup>	
			<b>Dimensions Limitations</b>
			-Extension limit e <sub>e</sub> < e <sub>r</sub> = 1
			-Compression limit e <sub>c</sub> < e <sub>r</sub> = 1
			-Knuckle radius (r <sub>m</sub> > 3·t) = 1
			-Max. liner OD OD <sub>L</sub> = 28-mm
			-Min. liner thk tl = 0.6-mm
			<b>Bellows Natural Frequency</b>
			-Axial vibration (Hz) f <sub>na</sub> = 29
			-Lateral vibration (Hz) f <sub>nl</sub> = 526
			-Rocking vibration (Hz) f <sub>nr</sub> = 299

# Thermal Expansion Of Pipe (inches per 100 feet of pipe)

Temp (°F)	Carbon Steel Carbon-Moly Low-Chrome (thru 3 Cr Mo)	5 Cr Mo thru 9 Cr Mo 18	Austenitic Stainless Steels Cr 8 Ni	12 Cr 17 Cr 27 Cr	25 Cr 20 Ni	Monel 67 Ni 30 Cr	3-1/2 Nickel	Aluminum	Gray Cast Iron	Bronze	Brass	Wrought Iron	70 Cu 30 Ni
-325	-2.37	-2.22	-3.85	-2.04	-3.00	-2.62	-2.22	-4.68		-3.98	-3.88	-2.70	-3.15
-300	-2.24	-2.10	-3.63	-1.92	-2.83	-2.50	-2.10	-4.46		-3.74	-3.64	-2.55	-2.87
-275	-2.11	-1.98	-3.41	-1.80	-2.66	-2.38	-1.98	-4.21		-3.50	-3.40	-2.40	-2.70
-250	-1.98	-1.86	-3.19	-1.68	-2.49	-2.26	-1.86	-3.97		-3.26	-3.16	-2.25	-2.53
-225	-1.85	-1.74	-2.96	-1.57	-2.32	-2.14	-1.74	-3.71		-3.02	-2.93	-2.10	-2.36
-200	-1.71	-1.62	-2.73	-1.46	-2.15	-2.02	-1.62	-3.44		-2.78	-2.70	-1.95	-2.19
-175	-1.58	-1.50	-2.50	-1.35	-1.98	-1.90	-1.50	-3.16		-2.54	-2.47	-1.81	-2.12
-150	-1.45	-1.37	-2.27	-1.24	-1.81	-1.79	-1.38	-2.88		-2.31	2.24	-1.67	-1.95
-125	-1.30	-1.23	-2.01	-1.11	-1.60	-1.59	-1.23	-2.57		-2.06	-2.00	-1.49	-1.74
-100	-1.15	-1.08	-1.75	-0.98	-1.39	-1.38	-1.08	-2.27		-1.81	-1.76	-1.31	-1.53
-75	-1.00	-0.94	-1.50	-0.85	-1.18	-1.18	-0.93	-1.97		-1.56	-1.52	-1.13	-1.33
-50	-0.84	-0.79	-1.24	-0.72	-0.98	-0.98	-0.78	-1.67		-1.32	-1.29	-0.96	-1.13
-25	-0.68	-0.63	-0.98	-0.57	-0.78	-0.77	-0.62	-1.32		-1.25	-1.02	-0.76	-0.89
0	-0.49	-0.46	-0.72	-0.42	-0.57	-0.57	-0.46	-0.97		-0.77	-0.75	-2.56	-0.66
25	-0.32	-0.30	-0.46	-0.27	-0.37	-0.37	-0.30	-0.63		-0.49	-0.48	-0.36	-0.42
50	-0.14	-0.13	-0.21	-0.12	-0.16	-0.20	-0.14	-0.28		-0.22	-0.21	-0.16	-0.19
70	0.00	0.00	0.00	0.00	0.00	0.00	0.00	0.00	0.00	0.00	0.00	0.00	0.00
100	0.23	0.22	0.34	0.20	0.28	0.28	0.22	0.46	0.21	0.36	0.35	0.26	0.31
125	0.42	0.40	0.62	0.36	0.51	0.52	0.40	0.85	0.38	0.66	0.64	0.48	0.56
150	0.61	0.58	0.90	0.53	0.74	0.75	0.58	1.23	0.55	0.96	0.94	0.70	0.82
175	0.80	0.76	1.18	0.69	0.98	0.99	0.76	1.62	0.73	1.26	1.23	0.92	1.07
200	0.99	0.94	1.46	0.86	1.21	1.22	0.94	2.00	0.90	1.56	1.52	1.14	1.33
225	1.21	1.13	1.75	1.03	1.45	1.46	1.13	2.41	1.08	1.86	1.83	1.37	1.59
250	1.40	1.33	2.03	1.21	1.70	1.71	1.32	2.83	1.27	2.17	2.14	1.60	1.86
275	1.61	1.52	2.32	1.38	1.94	1.96	1.51	3.24	1.45	2.48	2.45	1.83	2.13
300	1.82	1.71	2.61	1.56	2.18	2.21	1.69	3.67	1.64	2.79	2.76	2.06	2.40
325	2.04	1.90	2.90	1.74	2.43	2.44	1.88	4.09	1.83	3.11	3.08	2.29	2.68
350	2.26	2.10	3.20	1.93	2.69	2.68	2.08	4.52	2.03	3.42	3.41	2.53	2.96
375	2.48	2.30	3.50	2.11	2.94	2.91	2.27	4.95	2.22	3.74	3.73	2.77	3.24
400	2.70	2.50	3.80	2.30	3.20	3.25	2.47	5.39	2.42	4.05	4.05	3.01	3.52
425	2.93	2.72	4.10	2.50	3.46	3.52	2.69	5.83	2.62	4.37	4.38	3.25	
450	3.16	2.93	4.41	2.69	3.72	3.79	2.91	6.28	2.83	4.69	4.72	3.50	
475	3.39	3.14	4.71	2.89	3.98	4.06	3.13	6.72	3.03	5.01	5.06	3.74	
500	3.62	3.35	5.01	3.08	4.24	4.33	3.34	7.17	3.24	5.33	5.40	3.99	
525	3.86	3.58	5.31	3.28	4.51	4.61	3.57	7.63	3.46	5.65	5.75	4.25	
550	4.11	3.80	5.62	3.49	4.79	4.90	3.80	8.10	3.67	5.98	6.10	4.50	
575	4.35	4.02	5.93	3.69	5.06	5.18	4.03	8.56	3.89	6.31	6.45	4.76	
600	4.60	4.24	6.24	3.90	5.33	5.46	4.27	9.03	4.11	6.64	6.80	5.01	
625	4.86	4.47	6.55	4.10	5.60	5.75	4.51		4.34	6.96	7.16	5.27	
650	5.11	4.69	6.87	4.31	5.88	6.05	4.75		4.57	7.29	7.53	5.53	
675	5.37	4.92	7.18	4.52	6.16	6.34	4.99		4.80	7.62	7.89	5.80	
700	5.63	5.14	7.50	4.73	6.44	6.64	5.24		5.03	7.95	8.26	6.06	
725	5.90	5.38	7.82	4.94	6.73	6.94	5.50		5.26	8.28	8.64	6.32	
750	6.16	5.62	8.15	5.16	7.02	7.25	5.76		5.50	8.62	9.02	6.59	
775	6.43	5.86	8.47	5.38	7.31	7.55	6.02		5.74	8.96	9.40	6.85	
800	6.70	6.10	8.80	5.60	7.60	7.85	6.27		5.98	9.30	9.87	7.12	
825	6.97	6.34	9.13	5.82	7.89	8.16	6.54		6.22	9.64	10.17	7.40	
850	7.25	6.59	9.46	6.05	8.19	8.48	6.81		6.47	9.99	10.57	7.69	
875	7.53	6.83	9.79	6.27	8.48	8.80	7.08		6.72	10.33	10.96	7.97	
900	7.81	7.07	10.12	6.49	8.87	9.12	7.35		6.97	10.68	11.35	8.26	
925	8.08	7.31	10.46	6.71	9.07	9.44	7.72		7.23	11.02	11.75	8.53	
950	8.35	7.56	10.80	6.94	9.37	9.77	8.09		7.50	11.37	12.16	8.81	
975	8.62	7.81	11.14	7.17	9.66	10.09	8.46		7.76	11.71	12.57	9.08	
1000	8.89	8.06	11.48	7.40	9.95	10.42	8.83		8.02	12.05	12.98	9.36	
1025	9.17	8.30	11.82	7.62	10.24	10.75	9.18			12.40	13.39		
1050	9.46	8.55	12.16	7.95	10.54	11.09	9.54			12.76	13.81		
1075	9.75	8.80	12.50	8.18	10.83	11.43	9.92			13.11	14.23		
1100	10.04	9.05	12.84	8.31	11.12	11.77	10.35			13.47	14.65		
1125	10.31	9.28	13.18	8.53	11.41	12.11	10.78						
1150	10.57	9.52	13.52	8.76	11.71	12.47	11.11						
1175	10.83	9.76	13.86	8.98	12.01	12.81	11.44						
1200	11.10	10.00	14.20	9.20	12.31	13.15	11.78						
1225	11.38	10.26	14.54	9.42	12.59	13.50							
1250	11.66	10.53	14.88	9.65	12.88	13.86							
1275	11.94	10.79	15.22	9.88	13.17	14.22							
1300	12.22	11.06	15.56	10.11	13.46	14.58							
1325	12.50	11.30	15.90	10.33	13.75	14.94							
1350	12.78	11.55	16.24	10.56	14.05	15.30							
1375	13.06	11.80	16.58	10.78	14.35	15.66							
1400	13.34	12.05	16.92	11.01	14.65	16.02							
1425			17.30										
1450			17.69										
1475			18.08										
1500			18.47										

This data is for information purposes only and does not imply that materials are suitable for all the temperatures shown.

## Material Standards Comparison

International steel designation				ISO	National designations superseded by EN						
EN	ASTM	UNS	JIS		BS (UK)	DIN (Germany)	NF (France)	SS (Sweden)	BG/PR (China)	KS (Korea)	GOST (Russia)
<b>FERRITIC GRADES</b>											
1.4600						1.4600					
1.4512	406		SUS409		409S19	1.4512	Z3 CT12				
1.4003		S40977		4003-410-77-I		1.4003					
1.4000	410S	S41008	SUS403	4000-410-08-I	403S17	1.4000	Z8 C12	2301			08X13
1.4589		S42035		4589-429-70-E		1.4589					
1.4016	430	S43000	SUS430	4016-430-00-I	430S17	1.4016	Z8 C17	2320	1Cr17	STS 430	12X17
1.4511				4511-430-71-I		1.4511	Z4 CNb17				
1.4520				4520-430-70-I		1.4520					
1.4510	439	S43035	SUS430LX	4510-430-35-I							
1.4509		S43940		4509-439-40-X		1.4509	Z3 CT Nb 18				
1.4607						1.4607					
1.4113	434	S43400		4113-434-00-I	434S17	1.4113					
1.4513		S43600		4513-436-00-J		1.4513					
1.4521	444	S44400	SUS444	4521-444-00-I		1.4521	Z3 CDT 18-02	2326			
<b>MARTENSITIC AND PRECIPITATION HARDENING GRADES</b>											
1.4006	410	S41000	SUS410	4006-410-00-I	410S21	1.4006	Z10 C13	2302	1Cr12	STS 410	12X13
1.4005	416	S41600	SUS416	4005-416-00-I	416S21	1.4005	Z11 CF13	2380	Y1Cr13	STS 416	
1.4021	420	S42000	SUS420J1	4021-420-00-I	420S29	1.4021	Z20 C13	2303	2Cr13	STS 120J1	20X13
1.4031	420	S42000		4031-420-00-I	420S45	1.4031	Z33 C13	2304			
1.4034	420	S42000		4034-420-00-I		1.4034	Z44 C14				
1.4028	420	S42000	SUS420J2	4028-420-00-I	420S45	1.4028	Z33 C13	2304	3Cr13	STS420J2	30X13
1.4313		S41500	SUSTi6NM	4313-415-00-I		1.4313	Z6 CN 13-04	2385			
1.4542	630	S17400	SUS630			1.4542	Z7 CNU 16-04				
1.4116				4116-420-77-E		1.4116	Z50 CD15				
1.4110				4110-420-69-E		1.4110					
1.4568	631	S17700	SUS631			1.4568	Z9 CNA 17-07	2388			
1.4122				4122-434-19-I		1.4122					
1.4574	632	S15700				1.4574					
<b>FERRITIC HIGH TEMPERATURE GRADES</b>											
1.4713						1.4713					
1.4724				4724-405-77-I		1.4724	Z13 C13				10X13CI0
1.4736						1.4736					
1.4742				4742-430-77-I		1.4742	Z12 CAS18				
1.4762				4762-445-72-I		1.4762	Z12 CAS25				
<b>AUSTENITIC HIGH TEMPERATURE GRADES</b>											
1.4948	304H	S30409	SUS304	4948-304-09-I	304S51	1.4948	Z6 CN 18-09	2333	1Cr18Ni9	STS 304	08X18H10
1.4878	321H		SUS321		321S51	1.4878	Z6 CNT 18-10	2337	1Cr18Ni9Ti	STS 321	08X18H10T
1.4818		S30415		4818-304-15-E				2372			
1.4833	309S	S30908	SUS309	4833-309-08-I	309S16	1.4833	Z15 CN 23-13		0Cr23Ni13	STS309S	20X23H13
1.4828			SUH309	4828-305-09-I		1.4828	Z17 CNS 20-12		1Cr20Ni14Si2		08X20H14C2
1.4835		S30815		4835-308-15-U		1.4835		2368			
1.4845	310S	S31008	SUS310S	4845-310-08-E	310S16	1.4845	Z8 CN25-20	2361	0Cr25Ni20		10X23H18
1.4841	314	S31400		4841-314-00-E		1.4841	Z15 CNS 25-20				20X25H2052

## Material Standards Comparison

International steel designation				ISO	National designations superseded by EN						
EN	ASTM	UNS	JIS		BS (UK)	DIN (Germany)	NF (France)	SS (Sweden)	BG/PR (China)	KS (Korea)	GOST (Russia)
<b>DUPLEX GRADES</b>											
1.4162		S32101		4162-321-01-E							
1.4362		S32304		4362-323-04-I		1.4362	Z3 CN 23-04 Az	2327			
1.4662		S82441									
1.4662		S32205	SUS 329J3L	4462-318-03-I	318S13	1.4462	Z3 CND 22-05 Az	2377	00Cr22Ni5Mo3N	STS 329J3L	
1.4501		S32760		4501-327-60-I							
1.4410		S32750		4410-327-50-E			Z3 CND 25-06 Az	2328		STS 329J4L	
<b>AUSTENITIC GRADES</b>											
1.4310	301	S30100	SUS 301	4310-301-00-I	301S21	1.4310	Z11 CN 18-08	2331	1Cr17Ni7	STS 301	07X16H6
1.4618				4618-201-76-E		1.4618					
1.4318	301LN	S30153	SUS 301L	4318-301-53-I			Z3 CN 18-07 Az			STS 301L	
1.4376						1.4376					
1.4372	201	S20100	SUS 201	4372-201-00-I	284S16		Z12 CMN 17-07 Az		1Cr17Mn6Ni5N	STS 201	
1.4301	304	S30400	SUS304	4301-304-00-I	304S31	1.4301	Z7 CN 18-09	2333	0Cr18Ni9	STS 304	08X18H10
1.4307	304L	S30403		4307-304-03-I	304S11	1.4307	Z3 CN 18-10	2352	00Cr19Ni10	STS 304L	03X18H11
1.4311	304LN	S30453	SUS304LN	4311-304-53-I	304S61	1.4311	Z3 CN 18-10 Az	2371	00Cr18Ni10N	STS 304LN	
1.4541	321	S32100	SUS 321	4541-321-00-I	321S31	1.4541	Z6 CNT 18-10	2337	0Cr18Ni10Ti	STS 321	08X18H10T
1.4550	347	S34700	SUS 347	4550-347-00-I	347S31	1.4550	Z6 CNNb 18-10	2338	0Cr18Ni11Nb	STS 347	08X18H12B
1.4305	303	S30300	SUS 303	4305-303-00-I	303S31	1.4305	Z8 CNF 18-09	2346	0Cr18Ni11Nb		12X18H10E
1.4303	305	S30403	SUS305J1	4303-305-00-I	305S19	1.4303	Z1 CN 18-12	2333	0Cr18Ni11Nb	STS 305	06X18H11
1.4306	304L	S30430	SUS304L	4306-304-03-I	304S11	1.4306	Z3 CN 18-10	2352	0Cr18Ni11Nb	STS 304L	03X18H11
1.4567			SUSXM7	4567-304-30-I	304S17	1.4567	Z3 CNU 18-09 FF		0Cr18Ni11Nb		
1.4640						1.4640					
1.4401	316	S31600	SUS 316	4401-316-00-I	316S31	1.4401	Z7 CND 17-11-02	2347	0Cr17Ni12Mo2	STS 316	
1.4404	316L	S31603		4404-316-03-I	316S11	1.4404	Z3 CND 17-11-02	2348	00Cr17Ni14Mo2	STS 316L	03X17H14M2
1.4427											
1.4436	316	S31600	SUS 316	4436-316-00-I	316S33	1.4436	Z7 CND 18-12-03	2343	0Cr17Ni12Mo2	STS 316	
1.4432	316L	S31603		4432-316-03-I	316S13	1.4432	Z3 CND 18-14-03	2353	00Cr17Ni14Mo2	STS 316L	03X17H14M3
1.4406	316LN	S31653	SUS 316LM	4406-316-53-I	316S61	1.4406	Z3 CND 17-11-Az		00Cr17Ni12Mo2N	STS 316LN	
1.4441						1.4441					
1.4429		S31653	SUS316LN	4429-316-53-I	316S63	1.4429	Z3 CND 17-12 Az	2375	00Cr17Ni13Mo2N	STS 316LN	
1.4571	316Ti	S32100	SUS316Ti	4571-316-35-I	320S31	1.4571	Z6 CNDT 17-12	2350	0Cr18Ni12Mo2Ti	STS 316Ti	08X17H13M2T
1.4435	316L		SUS 316L	4435-316-91-I	316S13	1.4435	Z3 CND 18-14-03	2353	00Cr17Ni14Mo2	STS 316L	03X17H14M3
1.3952											
<b>HIGH PERFORMANCE AUSTENITIC GRADES</b>											
1.4438	317L	S31703	SUS 317L	4438-317-03-I	317S12	1.4438	Z3 CND 19-15-04	2367	00Cr19Ni13Mo3	STS 317L	
1.4439	317LMN	S31726		4439-317-26-E		1.4439	Z3 CND 18-14-05-Az				
1.4466		S31050		4466-310-50-E							
1.3964											
1.4539	904L	N08904		4539-089-04-I	904S13	1.4539	Z2 NCDU 25-20	2562		STS 317J5L	
1.4547		S31254	SUS 312L	4547-312-54-I				2378			
1.4529		N08926		4529-089-26-I							
1.4565		S34565		4565-345-65-I		1.4565					
1.4652		S32654		4652-326-54-I							

## Types Of Corrosion



Thorburn's flexible metal hoses are suitable for the transport of critical fluids if a sufficient resistance is ensured against all corrosive media that may occur during the lifetime of the hose. The flexibility of the hose's corrugated elements require their wall thickness to be considerably thinner than that of all other parts of the piping system. Special attention must be paid to all possible kinds of corrosion, especially pitting corrosion, intergranular corrosion, crevice corrosion and stress corrosion cracking. This leads to the fact that the corrugated flexible element that is exposed to the corrosive fluid has to be chosen from a material with even higher corrosion resistance than those of the piping system parts it is connected to.

According to EN ISO 8044, corrosion is the "physicochemical interaction between a metal and its environment that results in changes in the properties of the metal, and which may lead to significant impairment of the function of the metal, the environment, or the technical system, of which these form a part. This interaction is often of an electrochemical nature". Different types of corrosion may occur, depending on the material and on the corrosion conditions.



### Uniform Corrosion

A general corrosion proceeding at almost the same rate over the whole surface. This type of corrosion includes rust which commonly is found on unalloyed steel (e. g. caused by oxidation in the presence of water). Stainless steels can only be affected by uniform corrosion under extremely unfavorable conditions, e.g. caused by liquids, such as acids and salt solutions. The loss in weight is specified in g/m<sup>2</sup>h or as the reduction in the wall thickness in mm/year.



### Pitting Corrosion

A locally limited corrosion attack that may occur under certain conditions, called pitting corrosion on account of its appearance. It is caused by the effects of chlorine, bromine and iodine ions, especially when they are present in hydrous solutions. This selective type of corrosion cannot be calculated, unlike surface corrosion, and can therefore only be kept under control by choosing an adequate resistant material. The resistance of stainless steels to pitting corrosion increases in line with the molybdenum content in the chemical composition of the material.



### Crevice Corrosion

This type of corrosion is caused by the lack of oxygen in crevices which results in a localized attack on a metal surface at, or immediately adjacent to, the gap or crevice between two joining surfaces. The gap or crevice can be formed between two metals or a metal and non-metallic material. Examples of crevices are gaps and contact areas between parts, under gaskets or seals, inside cracks and seams and spaces filled with deposits.

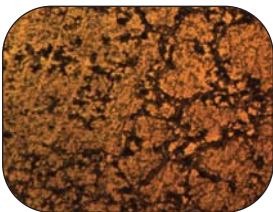

### Intergranular Corrosion

Intergranular corrosion is a local, selective type of corrosion which primarily affects the grain boundaries. It is caused by deposits in the material structure, which lead to a reduction in the corrosion resistance in the regions close to the grain boundaries. In stainless steels this type of corrosion can advance up to the point where the grain composition is dissolved. These deposit processes are dependent on temperature (critical temperature range is between 550°C and 650°C) and time in CrNi alloys. The onset of the deposit processes differs according to the type of steel. Intergranular corrosion can be avoided by using stainless steels with low carbon content ( $\leq 0,03\%$  C) or containing elements, such as titanium or niobium. Thin wall flexible elements made of materials such as 1.4541(SA 240 Type 321) or low-carbon qualities like 1.4404 (SA 240 Type 316L) can protect against intergranular corrosion. The resistance of materials to intergranular corrosion can be verified by a standardized test (Monypenny - Strauss test according to ISO 3651-2).

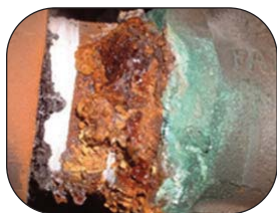

### Dezincing

A type of corrosion which occurs primarily in copper-zinc alloys with more than 20% zinc. During the corrosion process the copper is separated from the brass and the zinc either remains in solution or is separated in the form of basic salts above the point of corrosion. The dezincing can be either of the surface type or locally restricted, and can also be found deeper inside. Conditions which encourage this type of corrosion include thick coatings from corrosion products, lime deposits from the water or other deposits of foreign bodies on the metal surface. Water with high chloride content at elevated temperature in conjunction with low flow velocities further the occurrence of dezincing.



### Galvanic Corrosion

This type corrosion is an electrochemical process in which one metal corrodes preferentially when it is in electrical contact with another, in the presence of an electrolyte. A similar galvanic reaction is exploited in primary cells to generate a useful electrical voltage to power portable devices. Materials which can be encountered in both the active and passive state must also be taken into account. A CrNi alloy, for example, can be activated by mechanical damage to the surface, by deposits (diffusion of oxygen made more difficult) or by corrosion products on the surface of the material. This may result in a potential difference between the active and passive surfaces of the metal, and in material erosion (corrosion) if an electrolyte is present.



### Stress corrosion cracking (SCC)

This type of corrosion is observed most frequently in austenitic materials, subjected to tensile stresses and exposed to a corrosive agent. The most common corrosive agents are alkaline solutions and those containing chlorides. The form of the cracks may be either transgranular or intergranular. Whereas the transgranular form only occurs at temperatures higher than 50°C (especially in solutions containing chloride), the intergranular form can be observed already at room temperature in austenitic materials in neutral solutions containing chloride. At temperatures above 100°C, SCC can already be caused by very small concentrations of chloride or lye – the latter always leads to the transgranular form. Stress corrosion cracking takes the same forms in non-ferrous metals as in austenitic materials. Damage caused by intergranular stress corrosion cracking can occur in nickel and nickel alloys in highly concentrated alkalis at temperatures above 400°C, and in solutions or water vapour containing hydrogen sulphide at temperatures above 250°C. A careful choice of materials based on a detailed knowledge of the existing operating conditions is necessary to prevent from this type of corrosion damage.

Common Metallurgical Problems in Bellows		
Failure Mode	Cause	Solution
Chloride Stress Corrosion Cracking	Chlorides acting on austenitic stainless steel bellows (T-304, T-316, T-321)	Use a high nickel alloy like Inconel-600 or Inconel-625
Carbide Precipitation	Chromium carbides form in unstabilized stainless steels (T-304, T316) at high temperatures (over 700°F) causing loss of corrosion resistance	Use a stabilized stainless steel (T-321) or low carbon stainless steel (T-304L) or another high alloy material not affected by carbide precipitation
Pitting Corrosion	Galvanic action causing holes to form in a bellows, usually from acids	Use a bellows material containing molybdenum (T-316, I-825, I-625) or one of the specialty materials such as Zirconium, Titanium or Tantalum

# Corrosion Resistance Tables

## Table Key

### Meanings of abbreviations

- adp:** acid dew point
- bp:** boiling point
- cs:** cold-saturated (@ room temp)
- dr:** dry condition
- hy:** hydrous solution
- me:** melted
- mo:** moist condition
- sa:** saturated (@ boiling point)

Assessment	Corrosion Behavior	Suitability
A	Resistant	Suitable
B	Uniform corrosion with reduction in thickness of up to 1 mm/year	Restricted suitability
C	Risk of pitting corrosion	
D	Risk of stress corrosion cracking	
E	Hardly resistant, uniform corrosion with reduction in thickness of more than 1 mm/year up to 10 mm/year	Not recommended
F	Not resistant (different forms of corrosion)	Unsuitable

Medium		Materials																
Designation Chemical Formula	Concentration	Temperature	Non/Low Alloy Steels				Stainless Steels				Nickel Based Alloys				Copper Based Alloys		Pure Metals	
	%	°C	409, 410L, 430	SS304, SS321	SS316, SS316L	Incoloy 825 2.4858	Inconel 600 2.4816	Inconel 625 2.4856	Hastelloy-C 2.4610 C276 2.4819	Monel 2.4360	Alloy CuNi 70/30	Bronze	Titanium	Tantalum	Aluminum			
<b>Acetanilide (Antifebrine)</b> C <sub>8</sub> H <sub>9</sub> NO																		
<b>Acetic acid</b> CH <sub>3</sub> COOH or C <sub>2</sub> H <sub>4</sub> O <sub>2</sub>	5	20	F	A	A	A	B	A	A	B			A	A	A			
	50	20	F	F	F	F	A	A	A	B			A	A	A			
	80	20	F	F	F	F	A	A	A	B			A	A	A			
	96	20	F	F	F	F	A	A	A	B			A	A	A			
	98	20	F	F	F	F	A	A	A	B			A	A	A			
<b>Acetic acid vapour</b>	33	20	F	B	B	B	A	A	A	B			A	A	A			
	100	>50	F	F	F	F	A	A	A	B			A	A	A			
<b>Acetic aldehyde</b> CH <sub>3</sub> -CHO	100	bp	B	B	A	A	A	A	A	A	A	A	A	A	A			
<b>Acetic anhydride</b> (CH <sub>3</sub> -CO) <sub>2</sub> O	all	20	B	A	A	A	B	A	A	B	B	A	A	A	A			
	100	60	F	A	A	A	F	A	A			A	A	A	B			
<b>Acetic anilide</b> (Antifebrine)		<114	A	A	A	A	A	A	A	A	A	A	A	A	A			
<b>Acetone</b> CH <sub>3</sub> COCH <sub>3</sub>	100	bp	B	A	A	A	A	A	A	A	A	A	A	A	A			
<b>Acetyl chloride</b> CH <sub>3</sub> COCl		20	B	B	B	B	B	A	A	B	B	B		A	B			
<b>Acetylene</b> HC=CH	dr	200	A	A	A	A	A	A	A	A	F	F	A	A	A			
	dr																	
<b>Acetylene dichloride</b> C <sub>2</sub> H <sub>2</sub> Cl <sub>2</sub>	hy	5	20												B			
	dr	100	20	A	C	C	C	A	A	A					A			
<b>Acetylen tetrachloride</b> CHCl <sub>2</sub> -CHCl <sub>2</sub>	100	100	A	A	A	A				A			A	B	A			
<b>Adipic acid</b> HOOC(CH <sub>2</sub> ) <sub>4</sub> COOH	all	200	A	A	A	A	A	A	A	A			A	A	A			
<b>Alcohol</b> see ethyl or methyl alcohol																		

Medium		Materials																
Designation Chemical Formula	Concentration	Temperature	Non/Low Alloy Steels				Stainless Steels				Nickel Based Alloys				Copper Based Alloys		Pure Metals	
	%	°C	409, 410L, 430	SS304, SS321	SS316, SS316L	Incoloy 825 2.4858	Inconel 600 2.4816	Inconel 625 2.4856	Hastelloy-C 2.4610 C276 2.4819	Monel 2.4360	Alloy CuNi 70/30	Bronze	Titanium	Tantalum	Aluminum			
<b>Allyl alcohol</b> CH <sub>2</sub> CHCH <sub>2</sub> OH	100	bp																
<b>Allyl chloride</b> CH <sub>2</sub> =CHCH <sub>2</sub> Cl	100	25																
<b>Alum</b> KAl (SO <sub>4</sub> ) <sub>2</sub>	100	20	B	B	A	A	A	B	A									
	10	20	B	B	A	A	A											
	10	<80	B	B	F	F	F											
<b>Alum</b> KAl (SO <sub>4</sub> ) <sub>2</sub>	hy	hy																
<b>Aluminium</b> Al	me	750	B	B	B	B							B		B			
<b>Aluminium acetate</b> (CH <sub>3</sub> -COO) <sub>2</sub> Al(OH)	hy	3	20	F	A	A	A								A			
	sa														B			
<b>Aluminium chloride</b> AlCl <sub>3</sub>	hy	5	20	F	F	F	C	B	B	A	A	B	F	B	A			
<b>Aluminium fluoride</b> AlF <sub>3</sub>	hy	10	25	F	F	F	F						B	B	A			
<b>Aluminium formate</b> Al (HCOO) <sub>2</sub>				B	A	A	A	A	A	A	A	A		A	A			
<b>Aluminium hydroxide</b> Al (OH) <sub>3</sub>	hy	10	20	B	F	A	A	A							A			
<b>Aluminium nitrate</b> Al(NO <sub>3</sub> ) <sub>3</sub>				A	A	A	A	A	A	A	A	A			A			
<b>Aluminium oxide</b> Al <sub>2</sub> O <sub>3</sub>		20	B	B	A	A	A						F	A	A			
<b>Aluminium potassium sulphate</b> see alum																		
<b>Aluminium sulphate</b> Al <sub>2</sub> (SO <sub>4</sub> ) <sub>3</sub>	hy	10	<bp	F	F	F	F	A	A	B	B	B	B	F	F			
	sa	50	50	F	F	F	F	B	B	B	B	B	B	F	F			
<b>Ammonia</b> NH <sub>3</sub>	dr	10	20	A	A	A	A	A	A	A	A	A	A	A	A			
	hy	2	20	A	A	A	A	A	A	A	A	A	A	A	A			
	sa	40	40	A	A	A	A	A	A	A	A	A	A	A	A			



# Corrosion Resistance Tables

Medium				Materials															
Designation Chemical Formula	Concentration %	Temperature °C	Non/Low Alloy Steels	Stainless Steels			Nickel Based Alloys				Copper Based Alloys		Pure Metals						
				409, 410L, 430	SS304, SS321	SS316, SS316L	Incoloy 825 2.4858	Inconel 600 2.4816	Inconel 625 2.4856	Hastelloy-C 2.4610 C276 2.4819	Monel 2.4360	Alloy CuNi 70/30	Bronze	Titanium	Tantalum	Aluminium			
																	C	C	C
Bromine Br	dr mo	100 20	C C	C C	C C	C C	B	A	A	A	A	A	A	A	A	A	F	F	
Bromine water	0.03 1	20 20	C C	C C	C C	C C													
Bromofom CHBr <sub>3</sub>	dr mo	20	A F	A A	A A	A A	A A	A A	A A	A A	A A	A A	A A	A A	A A	A A	F	F	
1,3-Butadiene CH <sub>2</sub> =CHCH=CH <sub>2</sub>							A	A	A		A							A	
Butane C <sub>4</sub> H <sub>10</sub>	100 120	20 20	A A	A A	A A	A A	A A	A A	A A	A A	A A	A A	A A	A A	A A	A A			B
Butanol CH <sub>3</sub> -CH <sub>2</sub> -CH <sub>2</sub> -CH <sub>2</sub> OH	100 100	bp 100	A A	A A	A A	A A	A A	A A	A A	A A	A A	A A	A A	A A	A A	A A	A A	A A	A A
Butter		20	F	A	A	A	A	A	A										A
Buttermilk		20	F	A	A	A	A		A	A	F		F						A
Butylacetate CH <sub>3</sub> COOC <sub>4</sub> H <sub>9</sub>	20 bp	B A	A A	A A	A A	A A	A A	A A	A A	B A	A A	A A	A A	A A	A A	A A	A A	A A	A A
Butyric acid CH <sub>3</sub> -CH <sub>2</sub> -CH <sub>2</sub> -COOH	hy hy	cs sa	20 bp	F F	A A	A A	B A	F A	A A	A A	B A	A A	A A	A A	A A	A A	A A	A A	A B
Cadmium Cd	me				F	F													
Calcium Ca	me	850	F		F	F													
Calcium bisulphite CaSO <sub>3</sub>	cs sa	20 bp	F F	F F	A A	A A					B	B	A	A					
Calcium carbonate CaCO <sub>3</sub>		20	B	A	A	A	A	A	A	A	A	A	A	A	A	A	A	A	A
Calcium chlorate Ca(ClO <sub>3</sub> ) <sub>2</sub>	hy hy	10 10	20 100	F C	F C	F C	B B	B B	B B	B B	F B	F F						A	A
Calcium chloride CaCl <sub>2</sub>	hy hy	5 10 cs sa	100 20	F F C C	C C C C	C C C C	A A A A	A A A A	A A A A	A A A A	B A A A	A A A A	A A A A	A A A A	A A A A	A A A A	A A A A	F F F F	
Calcium hydroxide Ca(OH) <sub>2</sub>			A	A	A	A	B	B	A	A	B	A	A	A	A	A	A	A	F
Calcium hypochlorite Ca(OCl) <sub>2</sub>	hy hy	2 cs	20	F F	F F	F F	C	C	F	A	A	F	F					A	A
Calcium nitrate Ca(NO <sub>3</sub> ) <sub>2</sub>		20 100	F F	A A	A A	A A	A A	A A	A A	A A	A A	A A	A A	A A	A A	A A	A A	A A	A A
Calcium oxalate (COO) <sub>2</sub> Ca	mo		20	B	A	A	A	A	A	A	A	A	A	A	A	A	A	A	F
Calcium oxide CaO		20	A	A	A	A	A	A	A	A	A	A	A	A	A	A	A	A	F
Calcium sulphate CaSO <sub>4</sub>	mo mo	20 bp	B A	A A	A A	A A	A A	A A	A A	A A	A A	A A	A A	A A	A A	A A	A A	A A	B B
Calcium sulphite CaSO <sub>3</sub>	hy hy	cs sa	A A	A A	A A	A A												A	B
Carbolic acid C <sub>6</sub> H <sub>5</sub> (OH)	hy	90	A	A	A	A	A	B	A	A	B	A	A	A	A	A	A	A	A
Carbon dioxide CO <sub>2</sub>	dr dr mo mo	100 100 1000 20	A B F B	A A B B	A A B A	A A B A	A A A A	A A A A	A A A A	A A A A	A A A A	A A A A	A A A A	A A A A	A A A A	A A A A	A A A A	A A A A	
Carbo monoxide CO	100 100	20 -540	A F	A A	A A	A A	A A	A A	A A	A A	A A	A A	A A	A A	A A	A A	A A	A A	A B
Caustic-soda solution see sodium hydroxide																			
Chilean nitrate see sodium nitrate																			
Chloral CCl <sub>3</sub> -CHO		20																	A

Medium				Materials															
Designation Chemical Formula	Concentration %	Temperature °C	Non/Low Alloy Steels	Stainless Steels			Nickel Based Alloys				Copper Based Alloys		Pure Metals						
				409, 410L, 430	SS304, SS321	SS316, SS316L	Incoloy 825 2.4858	Inconel 600 2.4816	Inconel 625 2.4856	Hastelloy-C 2.4610 C276 2.4819	Monel 2.4360	Alloy CuNi 70/30	Bronze	Titanium	Tantalum	Aluminium			
																	F	F	B
Chloramine			F	F	B	A	A												
Chloric acid HClO <sub>3</sub>	hy	20	F	F	F	F	A											A	A
Chlorinated lime see calcium hypochlorite																			
Chlorine Cl <sub>2</sub>	dr dr mo mo	100 200 300 400 20 150	A F F F F	F F F F F	F F F F F	F F F F F	A	A	A	A	A	A	A	A	A	A	A	A	A
Chlorine dioxide ClO <sub>2</sub>	hy	0.5	20	F	F	F	F											B	A
Chloroacetic acid CH <sub>2</sub> Cl-COOH	hy	all 30	20 80	F F	F F	F F	F	F	B	B	F	F	F	A	A	A	A	F	F
Chlorobenzene C <sub>6</sub> H <sub>5</sub> Cl	dr mo	100	20	A	A	C	C	A	A	A	A	A	A	A	A	A	A	A	B
Chloroethane C <sub>2</sub> H <sub>5</sub> Cl - see ethyl chloride																			
Chloroform CHCl <sub>3</sub>	dr mo			B	F	B	C	B	C	A	A	A	A	A	A	A	A	A	A
Chloronaphthalene C <sub>10</sub> H <sub>7</sub> Cl				A	A	A	A	A	A	A	A	A	A	A	A	A	A	A	A
Chlorophenol C <sub>6</sub> H <sub>4</sub> (OH)Cl				B	A	A	A												
Chlorosulphon acid HOSO <sub>2</sub> Cl	hy mo	100 20	20	A	F	A	F	A	B	A	B	A	B	A	B	A	A	A	A
Chrome alum KCr(SO <sub>4</sub> ) <sub>2</sub>	hy	1 cs sa	20	F F F	F F F	F B F	A A F											B	A
Chromic acid Cr <sub>2</sub> O <sub>3</sub> (H <sub>2</sub> CrO <sub>4</sub> )	hy hy hy hy hy hy	5 5 90 10 10 50 60	20 20 20 65 bp bp 20	F F F F F F	F F F F F F	F F F F F F	A A A A A A	A A A A A A	A A A A A A	A A A A A A	B B F F F F	F F F F F F	A A A A A A	A A A A A A	A A A A A A	A A A A A A	A A A A A A	B B B B B B	
Chromic-acid anhydride see chromium oxide																			
Chromium oxide Cr <sub>2</sub> O <sub>3</sub>				A	A	A	A	A	A	A	A	A	A	A	A	A	A	A	A
Chromium sulphate Cr <sub>2</sub> (SO <sub>4</sub> ) <sub>3</sub>	cs sa			F	F	A	A	B	B	A	A	A	A	A	A	A	A	A	A
Cider				F	A	A	A	A	A	A	A	A	A	A	A	A	A	A	B
Citric acid C <sub>6</sub> H <sub>8</sub> O <sub>7</sub>	hy hy	all all	<80 bp	F F	F F	F F	A A	A A	A A	A A	A A	A A	A A	A A	A A	A A	A A	A A	A A
Combustion gases free from S or H <sub>2</sub> SO <sub>4</sub> and Cl with S or H <sub>2</sub> SO <sub>4</sub> and Cl				<400 >adp <400	A	A	A	A	A	A	A	A	A	A	A	A	A	A	A
Copper (II) acetate Cu <sub>2</sub> (CH <sub>3</sub> COO) <sub>4</sub>	hy hy	20 bp	F F	A A	A A	A A	A A	A A	A A	A A	B A	A A	A A	A A	A A	A A	A A	A A	F F
Copper (II) chloride CuCl <sub>2</sub>	hy hy	1 cs	20	F F	F F	C F	C F	A F	F F									A	A
Copper (II) nitrate Cu(NO <sub>3</sub> ) <sub>2</sub>	hy hy hy	1 50 cs	20 bp	A A A	A A A	A A A	A A A	A A A	A A A	A A A	A A A	A A A	A A A	A A A	A A A	A A A	A A A	A A A	F F F
Copper (II) sulphate CuSO <sub>4</sub>	hy hy	cs sa		F F	A A	A A	A A	A A	A A	A A	F F	A A	A A	A A	A A	A A	A A	A A	F F
Creosol C <sub>8</sub> H <sub>8</sub> (CH <sub>3</sub> )OH	all all	20 bp	F F	B B	A A	A A	A A	A A	A A	A A	A A	A A	A A	A A	A A	A A	A A	A A	A A
Crotonaldehyde CH <sub>3</sub> -CH=CH-CHO		20 bp	F		A	B	A	A	A	A	A	A	A	A	A	A	A	A	A
Cyclohexane (CH <sub>2</sub> ) <sub>6</sub>				A	A	A	A	A	A	A	A	A	A	A	A	A	A	A	A

# Corrosion Resistance Tables

Medium			Materials															
Designation Chemical Formula	Concentration Temperature	Non/Low Alloy Steels	Stainless Steels			Nickel Based Alloys				Copper Based Alloys		Pure Metals						
			409, 410L, 430	SS304, SS321	SS316, SS316L	Incoloy 825 2.4858	Inconel 600 2.4816	Inconel 625 2.4856	Hastelloy-C 2.4610 C276 2.4819	Monel 2.4360	Alloy CuNi 70/30	Bronze	Titanium	Tantalum	Aluminum			
																%	°C	%
Diammonium phosphate <i>see ammonium phosphate</i>																		
Dibromomethane CH <sub>2</sub> Br-CH <sub>2</sub> Br			B		A	A												F
Dichlorofluoromethane CF <sub>2</sub> Cl <sub>2</sub>	dr dr mo	bp 20 20		A	A	A	A	A	A	A	A				A	A	A	A
Dichloroethane CH <sub>2</sub> Cl-CH <sub>2</sub> Cl	dr mo	100 20 100	A	C	C	C	B	A			A			A	A	A	A	A
Dichloroethylene <i>see acethylene dichloride</i>																		
Diethyl ether (C <sub>2</sub> H <sub>5</sub> ) <sub>2</sub> O			A	A	A	A	A	A	A	B	A	A	A	A	A	A	A	A
Ethane CH <sub>3</sub> -CH <sub>3</sub>		20	A	A	A	A	A	A	A	A	A	A	A	A	A	A	A	A
Ether <i>see diethyl ether</i>																		
Ethereal oils		20	B	A	A	A	A	A	A	B	A	A	A	A	A	A	A	A
Ethyl alcohol C <sub>2</sub> H <sub>5</sub> OH	all all	20 bp	A	A	A	A	A	A	A	A	A	A	A	A	A	A	A	A
Ethylbenzene C <sub>6</sub> H <sub>5</sub> -C <sub>2</sub> H <sub>5</sub>			B	A	A	A	A	A	A	A	A	A	A	A	A	A	A	A
Ethyl chloride C <sub>2</sub> H <sub>5</sub> Cl			A	D	D	D	A	A	A	B	A	A	B		A	B		
Ethylene CH <sub>2</sub> =CH <sub>2</sub>		20	A	A	A	A												A
Ethylene dibromide CH <sub>2</sub> Br-CH <sub>2</sub> Br			B		A	A												F
Ethylene dichloride CH <sub>2</sub> ClCH <sub>2</sub> Cl	dr mo	100 20 100	A	C	C	C	B	A			A			A	A	A	A	A
Ethylene glycol CH <sub>2</sub> OH-CH <sub>2</sub> OH		100 20	A	A	A	A	A	B	A	A	B	A	A	A	A	A	A	A
Exhaust gases <i>see combustion gases</i>																		
Fats			A	A	A	A	A	A	A	A	A	A	A	A	A	A	A	A
Fatty acid C <sub>17</sub> H <sub>35</sub> COOH	100 100 100 100 100	20 60 150 180 300	A F F F F	A F F F F	A A A A A	A A A A A	A A A A A	A A A A A	A A A A A	B A B B	B B B F	A B A A	A A A A	A A A A	A A A A	A B A A	A F F F	
Fixing salt <i>see sodium thiosulphate</i>																		
Flue gases <i>see combustion gases</i>																		
Fluorine	mo dr dr dr	100 200 100 500	F A A A	F A A A	F A C C	F A C C				A A A A	A A A A	F A A A	B A A A	F A A A	F A A A	F A A A	F F F F	
Fluorosilicic acid H <sub>2</sub> (SiF <sub>6</sub> )		100 25 70	F F F	F F F	F F F	F F F	B B B	B B B	F B B	F B B	F B B	F B B	F B B	F B B	F B B	F B B	F F F	
Formaldehyde CH <sub>2</sub> O	hy hy hy	10 40 all	F F F	A A A	A A A	A A A	A A A	A A A	A A A	A A A	A A A	A A A	A A A	A A A	A A A	A A A	B B B	
Formic acid HCOOH		10 10 80 85	F F F F	F F F F	B B B B	A A A A	B A B A	A B A A	A A A A	B B F E				A A F F	A A F F	A A F F	F F F F	

Medium			Materials															
Designation Chemical Formula	Concentration Temperature	Non/Low Alloy Steels	Stainless Steels			Nickel Based Alloys				Copper Based Alloys		Pure Metals						
			409, 410L, 430	SS304, SS321	SS316, SS316L	Incoloy 825 2.4858	Inconel 600 2.4816	Inconel 625 2.4856	Hastelloy-C 2.4610 C276 2.4819	Monel 2.4360	Alloy CuNi 70/30	Bronze	Titanium	Tantalum	Aluminum			
																%	°C	%
Fuels																		
Benzene		20 bp	A	A	A	A	A	A	A	A	A	A	A	A	A	A	A	A
Benzene-alcohol-mixture Diesel oil		20 20	A	A	A	A	A	A	A	A	A	A	A	A	A	A	A	A
Furfural		100 25 100	B F	B B	B B					A		A	A	A	A	A	A	
Galic acid C <sub>6</sub> H <sub>4</sub> (OH) <sub>3</sub> COOH	hy	1 100 100	B F F	A A A	A A A					A							A A A	
Gelatine		20 80	A B	A A	A A	A A				A		A	A	A	A	A	A	
Glacial acetic acid CH <sub>3</sub> CO <sub>2</sub> H <i>see acetic acid</i>																		
Glass	me	1200	B		B	B												
Glauber salt <i>see sodium sulphate</i>																		
Gluconic acid CH <sub>2</sub> OH(CHOH) <sub>4</sub> -COOH		100 20	B	A	A	A	A	A	A	A	A	A	A	A	A	A	A	
Glucose C <sub>6</sub> H <sub>12</sub> O <sub>6</sub>	hy	20		A	A	A						A	A	A	A	A		
Glutamic acid HOOC-CH <sub>2</sub> -CH <sub>2</sub> -CHNH <sub>2</sub> -COOH		20 80	B F	C C	C C	A A	A B	A A	B A	B A								
Glycerine CH <sub>2</sub> OH-CHOH-CH <sub>2</sub> OH		100 20 100	A B	A B	A A	A A	A A	A A	A A	A A	A A	A A	A A	A A	A A	A A	A A	
Glycol <i>see ethylene glycol</i>																		
Glycolic acid CH <sub>2</sub> OH-COOH		20 bp	F F	B F	B F	B F								A			A B	
Glystantine <i>see antifreeze</i>																		
Hexachloroethane CCl <sub>2</sub> -CCl <sub>2</sub>		20			A	A	A	A	A	A	A	A	A	A	A	A	F	
Hexamethylene - tetramine (CH <sub>2</sub> ) <sub>6</sub> N <sub>4</sub>	hy hy	20 60 80	B F		A	A								A				
Household ammonia <i>see ammonium hydroxide</i>																		
Hydrazene H <sub>2</sub> N-NH <sub>2</sub>		20	A		A		F	F				F					B	
Hydrazine sulphate (NH <sub>2</sub> ) <sub>2</sub> H <sub>2</sub> SO <sub>4</sub>	hy	10 bp	F		F	F												
Hydrobromic acid aqueous solution of hydrogen bromide (HBr)		20	F	F	F	F	F	F	F	F	F	F	F	F	F	F	F	
Hydrochloric acid HCl		0.2 0.5 0.5 1 2 15 32 32	F F F F F F F	F F F F F F F	F F F F F F F	F F F F F F F	F F F F F F F	F F F F F F F	F F F F F F F	F F F F F F F	F F F F F F F	F F F F F F F	F F F F F F F	F F F F F F F	F F F F F F F	F F F F F F F		
Hydrochloric-acid gas <i>see hydrogen chloride</i>																		
Hydrofluoric acid HF		10 80 80 90	F B	F	F	F	F	F	F	F	F	F	F	B	B	B	F F F F	

# Corrosion Resistance Tables

Medium			Materials												
Designation Chemical Formula	Concentration Temperature	Non/Low Alloy Steels	Stainless Steels			Nickel Based Alloys				Copper Based Alloys		Pure Metals			
			409, 410L, 430	SS304, SS321	SS316, SS316L	Incoloy 825 2.4858	Inconel 600 2.4816	Inconel 625 2.4856	Hastelloy-C 2.4610 C276 2.4819	Monel 2.4360	Alloy CuNi 70/30	Bronze	Titanium	Tantalum	Aluminium
Hydrogen H		-300 -300	A F	A A	A A	A A	A A	A A	A A	A A				A A	
Hydrogen bromide HBr	dr mo	100 30	F F	F F	F F	F F	F F	F F	F F	F F				A A	
Hydrogen chloride HCl	dr dr dr dr	20 100 250 500	A A B F	F F F F	F F F F	F F F F	A A A A	A A A A	A A A A	A A A A				B B F F	
Hydrogen cyanide HCN	dr hy hy	20 20 20	F B F	A B A	A A A	A A A	A A A	A A A	A A A	B F F	F F F	A A A	A A A	A A A	
Hydrogen fluoride HF		5 100	F F	F F	F F	F F	F F	F F	F F	F F	F F	F F	F F	F F	
Hydrogen peroxide H <sub>2</sub> O <sub>2</sub>		all	F	F	F	F	F	F	F	F	F	F	F	F	
Hydrogen sulphide H <sub>2</sub> S	dr dr dr mo	100 100 200 100	B F F F	D D A A	A A A A	A A A A	A A A A	B A A A	A A A A	B A A A	A A A A	A A A A	A A A A		
Hydroiodic acid	dr mo	20 20	A F	F F	F F	F F	F F	F F	F F	F F					
Hypochlorous acid HOCl		20	F	F	F	F	F	F	F	F				F	
Indol		20	A	A	A	A	A	A	A	A	A	A	A	A	
Ink <i>see gallic acid</i>															
Iodine I <sub>2</sub>	dr mo mo	100 20 bp	F F F	C F F	C F F	C F F	C F F	A B B	A F F	F F F	F F F	F A A	A A A	A F F	
Iodoform CHI <sub>3</sub>	dr mo	60 20	A F	A C	A C	A C	A C							A	
Iron (II) chloride FeCl <sub>2</sub>	hy hy	10 cs	A	C	C	C	F	F	B	F	B	B	A	A	
Iron (II) sulphate FeSO <sub>4</sub>	hy	all	bp	A	A	A	A	A	A	A	A	A	A	F	
Iron (III) chloride FeCl <sub>3</sub>	dr hy hy hy	100 5 10 50	F F F F	C F B B	C F B B	C F B B	F F F F	A A F B	F F F F	F F F F	F F F F	A A A A	A A A A	B B	
Iron (III) nitrate Fe(NO <sub>3</sub> ) <sub>3</sub>	hy hy	10 all	bp	F	A	A	A	F	F	F	F	F	F	A	
Iron (II) sulphate FeSO <sub>4</sub>	hy	all	bp	A	A	A	A	A	A	A	A	A	A	A	
Iron (III) sulphate Fe(SO <sub>4</sub> ) <sub>3</sub>	hy hy	<30 all	bp	F	A	A	A	A	F	A	B	F	F	A	
Isatine C <sub>8</sub> H <sub>5</sub> NO <sub>2</sub>		20	B	A	A	A	A	A	A	A	A	A	A	A	
Kalinite <i>see alum</i>															
Ketene R <sub>2</sub> C=C=O		20	bp	A	A	A	A	A	A	A	A	A	A	A	
Lactic acid C <sub>3</sub> H <sub>5</sub> O <sub>3</sub>	hy hy hy	1 all 10	all	F F F	F F F	F F F	F F F	A A A	A A A	A A A	A A A	A A A	A A A	A B B	
Lactose C <sub>12</sub> H <sub>22</sub> O <sub>11</sub>	hy	20	A	A	A	A	A	A	A	A	A	A	A	A	
Lead Pb	me	388 900	F F	B F	B F	B F	B F	A	A	F			A	A	
Lead acetate (CH <sub>3</sub> -COO) <sub>2</sub> Pb	me		F	A	A	A	A		A	A	F			F	
Lead acide Pb(NO <sub>3</sub> ) <sub>2</sub>		<20 <30						A	A	A	B				

Medium			Materials												
Designation Chemical Formula	Concentration Temperature	Non/Low Alloy Steels	Stainless Steels			Nickel Based Alloys				Copper Based Alloys		Pure Metals			
			409, 410L, 430	SS304, SS321	SS316, SS316L	Incoloy 825 2.4858	Inconel 600 2.4816	Inconel 625 2.4856	Hastelloy-C 2.4610 C276 2.4819	Monel 2.4360	Alloy CuNi 70/30	Bronze	Titanium	Tantalum	Aluminium
Lead nitrate Pb(NO <sub>3</sub> ) <sub>2</sub>	hy	100	B	A	A	A	A	A	A	A	A	A	A	A	
Lime CaO <i>see calcium oxide</i>															
Lithium Li	me	300	A	A	A	A	A	A	A	F	F	F	A	F	
Lithium chloride LiCl	hy	cs		F	F	F	C	A	A	A	A	B		A	
Lithium hydroxide LiOH	hy	all	20	B	A	A	A	A	A	A	A	A	A	A	
Magnesium Mg	me	650		B	F	F	F	F	F	F	F	F	F	A	
Magnesium carbonate MgCO <sub>3</sub>	hy hy	20 bp	A	A	A	A	A	A	A	A	A	A	A	B	
Magnesium chloride MgCl <sub>2</sub>	hy hy hy	5 5 50	20 bp	F F F	F F F	F F F	C C C	A A A	A A A	A A A	A A A	A A A	A A A	F F F	
Magnesium hydroxide Mg(OH) <sub>2</sub>	hy hy	cs sa		A	A	A	A	A	A	A	A	A	A	A	
Magnesium nitrate Mg(NO <sub>3</sub> ) <sub>2</sub>		cs		A	A	A	A	F	F		F	A	F	A	
Magnesium oxide <i>see magnesium hydroxide</i>															
Magnesium sulphate MgSO <sub>4</sub>	hy hy hy	0.1 5 50	20 bp	A F F	B B B	A A A	A A A	A	B	A	A	A	B	A	
Maleic acid HOOC-CH=CH-COOH	hy hy	5 50	20 100	F F	A A	A A	A A	A	B	A	A	A	B	A	
Maleic anhydride		100	285										A		
Mallic acid	hy hy	50	20	F	F	F	A	A	A	A	B	A	A	A	
Malonic acid CH <sub>2</sub> (COOH) <sub>2</sub>		20 50 100				B	B	B	B	B	B	B	B	B	
Manganese(II) chloride MnCl <sub>2</sub>	hy hy	5 50	100	F	C	C	C	C	B	B	B	B	B	B	
Manganese(II) sulphate MnSO <sub>4</sub>		cs		A	A	A	A	A	A	A	A	A	A	A	
Maritime climate	mo			EC	BC	BC	BC	A	A	A	A	A	A	A	
Methanol <i>see methyl alcohol</i>															
Menthol C <sub>10</sub> H <sub>18</sub> O					A	A	A	A	A	A	A	A	A	A	
Mercury Hg	dr	100	<500	A	B	C	C	C	A	A	A	A	A	A	
Methane CH <sub>4</sub>		200 600		A	A	A	A	A	A	A	A	A	A	A	
Methyl acetate CH <sub>3</sub> COOCH <sub>3</sub>		60 60	bp	A	A	A	A	A	A	A	A	A	A	A	
Methyl alcohol CH <sub>3</sub> OH		<100 100	bp	B	F	F	B	B	B	A	A	A	A	A	
Methylamine CH <sub>3</sub> -NH <sub>2</sub>	hy	25	20	B	A	A	A	A	A	A	F	F	F	A	
Methyl chloride CH <sub>3</sub> Cl	dr mo mo	20 20 bp		A	C	C	C	C	C	C	C	C	C	A	
Methyldehyde <i>see formaldehyde</i>															
Methylene dichloride CH <sub>2</sub> Cl <sub>2</sub>	dr mo mo	20 20 bp		A	C	C	C	C	C	C	C	C	C	A	



# Corrosion Resistance Tables

Medium				Materials														
Designation Chemical Formula	Concentration %	Temperature °C	Non/Low Alloy Steels	Stainless Steels			Nickel Based Alloys					Copper Based Alloys		Pure Metals				
				409, 410L, 430	SS304, SS321	SS316, SS316L	Incoloy 825 2.4858	Inconel 600 2.4816	Inconel 625 2.4856	Hastelloy-C 2.4610 C276 2.4819	Monel 2.4360	Alloy CuNi 70/30	Bronze	Titanium	Tantalum	Aluminum		
				Potassium carbonate K <sub>2</sub> CO <sub>3</sub>	hy hy	50 50	20 bp	F F	A A	A A	A A	A A	A A	A A	A A	A A	A A	B B
Potassium chlorate KClO <sub>3</sub>	hy hy	5 sa	20	F F	A A	A A	A A	A A	A A	A A	A A	A A	A A	B B	F F	B B		
Potassium chloride KCl	hy hy hy hy hy	10 10 30 cs sa	-20 bp	F F F F F	F F F F F	C C C C C	C C C C C	A A A A A	A A A A A	A A A A A	A A A A A	A A A A A	A A A A A	A A A A A	A A A A A			B B B B B
Potassium chromate K <sub>2</sub> CrO <sub>4</sub>	hy hy	10 10	20 bp	A B	A A	A A	A A	A A	A A	A A	A A	A A	A A	B B	A A	A A	A A	A A
Potassium cyanide KCN	hy hy	10 10	20 bp	F F	A A	A A	A A	A A	F F		A A	B B	F F	F F	F F		A A	F F
Potassium dichromate K <sub>2</sub> Cr <sub>2</sub> O <sub>7</sub>	hy hy hy	10 25 40	40 bp	F F F	A A A	A A A	A A A	B B B	B B B	B B B	B B B	B B B	B B B	A A A	F F F	B B B	A A A	A A A
Potassium ferricyanide K <sub>3</sub> (Fe(CN) <sub>6</sub> )	hy hy hy	1 cs sa	20	A F	A A A	A A A	A A A	B B B	A A A	A A A	A A A	A A A	A A A	A A A	A A A	A A A	A A A	A A A
Potassium ferrocyanide K <sub>4</sub> (Fe(CN) <sub>6</sub> )	hy hy hy	1 25 25	20 bp	A B	A A A	A A A	A A A	B B B	A A A	A A A	A A A	A A A	A A A	A A A	A A A	A A A	A A A	A A A
Potassium fluoride KF	hy hy	cs sa		A B	A A	A A	A A			A A								F
Potassium hydroxide	hy hy hy hy hy hy me	10 20 30 50 50 100	20 bp bp bp bp sa 360	D D D D D D F	A A A A A A F	D D D D D D F	D D D D D D F	B B B B B B F	B B B B B B F	B B B B B B F	B B B B B B F	B B B B B B F	A A A A A A F	A A A A A A F	A A A A A A F	A A A A A A F	F F F F F F F	
Potassium hypochlorite KClO	hy hy	all all	20 bp	C C	C C	C C	C C	F F	F F		A B	F F	F F	A A	A A	A A	A A	F F
Potassium iodide KI	hy hy	20 bp	A C	A C	C C	C C	C C	A B	B B	B B	A A	F F	A A	A A	A A	A A	A A	F F
Potassium nitrate KNO <sub>3</sub>	hy hy	all all	20 bp	A A	A A	A A	A A	A B	B B	B B	B B					A A	A A	B B
Potassium nitrite KNO <sub>2</sub>	all	bp	B	A	A	A	A	B	A	A	A	A	B	B				
Potassium permanganate KMnO <sub>4</sub>	hy hy	10 all	20 bp	A F	A B	A B	A B	A A	B B	B B	A A	B B	A A	A A	A A	A A	A A	A A
Potassium persulphate K <sub>2</sub> S <sub>2</sub> O <sub>8</sub>	hy	10	50	F	F	A	A		A		A	F		F	A			F
Potassium silicate K <sub>2</sub> SiO <sub>3</sub>		20	B	A	A	A	A	A	A	A	A	A	A	A	A	A	A	F
Potassium sulphate K <sub>2</sub> SO <sub>4</sub>	hy hy	10 all	25 bp	F A	A A	A A	A A	A A	A A	A A	A A	A A	A A	A A	A A	A A	A A	A B
Protein solutions		20	B	A	A	A	A	A	A	A	A	A	A	A	A	A	A	A
Pyridine C <sub>5</sub> H <sub>5</sub> N	dr	all	bp	A	A	A	A		A	A	A	A			A	A	A	
Pyrogallol C <sub>3</sub> H <sub>3</sub> (OH) <sub>3</sub>	all all	20 bp	F A	A A	A A	A A	A A			A A				A A	A A	A A	A A	
Quinine bisulphate	dr	20	F	F	F	A	A		A	A	B	A		A	A			
Quinine sulphate	dr	20	F	A	A	A	A		A	A	B	A		A	A			
Quinol HO-C <sub>6</sub> H <sub>4</sub> -OH			F		A	A	A	A	A		B	A					A	
Salicylic acid HOC <sub>6</sub> H <sub>4</sub> COOH	dr mo hy	100 100 cs	20 bp F	B F	A A	A A	A A	B A	A A	A A	B A	A A	A A	A A	A A	A A	A A	B
Salmiac see ammonium chloride																		

Medium				Materials															
Designation Chemical Formula	Concentration %	Temperature °C	Non/Low Alloy Steels	Stainless Steels			Nickel Based Alloys					Copper Based Alloys		Pure Metals					
				409, 410L, 430	SS304, SS321	SS316, SS316L	Incoloy 825 2.4858	Inconel 600 2.4816	Inconel 625 2.4856	Hastelloy-C 2.4610 C276 2.4819	Monel 2.4360	Alloy CuNi 70/30	Bronze	Titanium	Tantalum	Aluminum			
				Salpetre see potassium nitrate															
Seawater at flow velocity v (m/s) 0 < v ≤ 1.5 1.5 < v < 4.5		20 20	B B	C A	C A	C A	C C	C A	A A	A A	A A	C A	B A	F F	F F	F F	A A	A A	
Siliceous flux acid see fluorsilicic acid																			
Silver nitrate AgNO <sub>3</sub>	hy hy hy hy me	10 10 20 40 100	20 bp 60 20 250	F F F F F	A A A A A	A A A A A	A A A A A	A A A A A	A A A A A	B B	B B	B B	B B	F F	F F	F F	A A	A A	
Soap	hy hy hy	1 1 10	75 20	A A A	A A A	A A A	A A A	A A A	A A A	A A A	A A A	A A A	A A A	A A A	A A A	A A A	A A A	A A A	
Sodium (O <sub>2</sub> 0.005 %) Na	me	200 600	A F	A B	A A	A A											A A	B	
Sodium acetate CH <sub>3</sub> -COONa	hy hy	10 sa	25	A F	A A	A A	A A	A A	A A	A A	A A	A A	A A	A A	A A	A A	A A	A A	
Sodium aluminate Na <sub>2</sub> AlO <sub>3</sub>	hy	100 10	20 25	A A	A A	A A	A A						B				A A	F	
Sodium arsenate Na <sub>2</sub> HAsO <sub>4</sub>	hy	cs		A	A	A	A										A	A	
Sodium bicarbonate NaHCO <sub>3</sub>	hy hy hy	100 10 cs sa	20 20	A	A	A	A	A	A	A	A	A	A	A	A	A	B	A	A
Sodium bisulphate NaHSO <sub>4</sub>	hy hy	all all	20 bp	F F	F F	F F	F F	B A	B A	B B	B B	B B	B B	B B	F F	B B	A A	A B	
Sodium bisulphite NaHSO <sub>3</sub>	hy hy hy	10 50 50	20 bp	F F F	F A A	F A A	F A A						B B	A A	A A	A A	A A		
Sodium borate NaB <sub>3</sub> O <sub>4</sub> 4 H <sub>2</sub> O	hy me	cs		F	A	F	F	A	A	A	A	A	A	A	F	B	A	A	
Sodium bromide NaBr	hy hy	all all	20 bp	F F	F F	F F	F C						B B				A A	F F	
Sodium carbonate Na <sub>2</sub> CO <sub>3</sub>	hy hy me	B all 400 900	20 bp	F F F	A A F F	A A F F	A A F F	A A A A	A A A A	A A A A	A A A A	A A A A	A A A A	A A A A	A A A A	A A A A	A A A A	E F	
Sodium chloride NaCl	hy hy hy	0.5 2 cs sa	20 20	F F	C C C	C C C	C C C	A A A	B B B	A A A	A A A	A A A	A A A	A A A	A A A	A A A	A A A	E F	
Sodium chlorite NaClO <sub>2</sub>	dr hy hy hy	100 5 5 10	20 bp 80	F F	C F F	C F F	C F F	A A					B B				A A		
Sodium chromate Na <sub>2</sub> CrO <sub>4</sub>	hy	all	bp	A	A	A	A	A	A	A	A	A	A	A	A	A	A	A	
Sodium cyanide NaCN	me hy	600 B	B B	A	A	A	A							F F	F B	F F	A	F F	
Sodium fluoride NaF	hy hy hy	10 10 cs	20 bp	A A	A A	A A	A D									F		A	
Sodium hydrogensulphate see sodium bisulphate																			
Sodium hydrogensulphite see sodium bisulphite																			



# Corrosion Resistance Tables

Medium		Materials															
Designation Chemical Formula	Concentration Temperature	Non/Low Alloy Steels			Stainless Steels				Nickel Based Alloys				Copper Based Alloys		Pure Metals		
		%	°C	Non/Low Alloy Steels	409, 410L, 430	SS304, SS321	SS316, SS316L	Incoloy 825 2.4858	Inconel 600 2.4816	Inconel 625 2.4856	Hastelloy-C 2.4610 C276 2.4819	Monel 2.4360	Alloy CuNi 70/30	Bronze	Titanium	Tantalum	Aluminum
Trichloromethane <i>see chloroform</i>																	
Tricresylphosphate				A	A	A	A	A	A	A	A						
Trinitrophenol <i>see picric acid</i>																	
Trichloroacetic acid <i>see chloroacetic acid</i>																	
Urea CO(NH <sub>2</sub> ) <sub>2</sub>	100 100	20 150	A F	A B	A A	A A	A A	A A	A A	A A	A A	A A	A A	A A	A A	A A	A F
Uric acid C <sub>2</sub> H <sub>4</sub> O <sub>4</sub> N <sub>2</sub>	hy hy	20 100	F F	A A	A A	A A	A A	A A	B A	A A	A A	A A	A A	A A	A A	F F	F F
Vinyl chloride CH <sub>2</sub> =CHCl	dr	20 400	A A	A A	A A	A A	A A			A A	A A		A	A	A		A
Water vapour <i>see steam</i>																	
Wine		20 bp	F F	A A	A A	A A	A A	A A					F F		A A	F F	F F
Yeast		20	B	A	A	A	A	A	A	A	A	A	A	A	A	A	A
Yellow potassium prussiate <i>see potassium ferricyanide</i>																	
Zinc chloride ZnCl <sub>2</sub>	hy hy hy hy	5 10 20 75	20 20 20 20	F F F F	C C C C	C C C C	C C C C	A A	B F	A A	A B	B F F	F F F	F	A A A A	A A A A	F F A
Zinc sulphate ZnSO <sub>4</sub>	hy hy hy cs sa	2 30 30	20 bp bp	F F F F	A A A A	A A A A	A A A A	A A	B A	A A	A B B B	A A	A A	A A	A A A A	A A A A	A F F B F

### Hastelloy® C-276. UNS N10276 / EN 2.4819

A nickel-chromium-molybdenum super alloy with addition of tungsten designed to have excellent corrosion resistance for severe environments. Especially resistant to pitting and crevice corrosion. Resistant to the formation of grain boundary precipitants in the heat affected zone making it suitable for most chemical process applications in an as-welded condition.

### T-300 Series Stainless Steel (Austenitic)

Thorburn's metal hose is typically made from austenitic stainless steel, such as, 304, 304L, 316, 316L & 321

### T-304 Stainless Steel UNS S30400 / EN 1.4301

T-304 is the most commonly used stainless in the world and is referred to as 18/8. It is weldable, machinable with the right techniques, and has good corrosion resistance.

### T-304L Stainless Steel UNS S30403 / EN 1.4307

T-304L has reduced or low carbon to eliminate carbide precipitation due to welding so the alloy can be used in the "as welded" condition even in severe corrosive conditions.

### T-316 Stainless Steel UNS S31600 / EN 1.4401

T316 stainless steel is 18/8 with the inclusion of molybdenum (Mo) in the alloy. To give better overall corrosion resistant properties than Grade 304, particularly higher resistance to pitting and crevice corrosion in chloride environments.

### T-316L Stainless Steel UNS S31603 / EN 1.4404

T-316L has reduced or low carbon to eliminate carbide precipitation and offers higher creep, stress to rupture and tensile strength at elevated temperatures.

### T-321 Stainless Steel UNS S32100 / EN 1.4541

Type 321 is an austenitic chrome nickel steel stabilized with titanium. This material has similar properties to alloy 304, but its titanium content limits carbide precipitation, making it somewhat easier to machine. This grade is recommended for parts fabricated by welding which cannot be subsequently annealed.

## Material Selection At A Glance

### Bronze®

Alloy consisting of primarily copper (Cu) and around 12% tin (Sn) alloy

### Monel® 400. UNS N04400 / EN 2.4360

A high nickel-copper alloy which offers superior strength and corrosion resistance with a wide range of media including seawater and chlorine.

### Inconel® 625. UNS N06625 / EN 2.4856

A nickel-chromium-molybdenum super alloy with an addition of niobium that acts with the molybdenum to stiffen the alloy matrix and provides ultra-high strength without the need for heat treatment. This material provides superior resistance to pitting and crevice corrosion. Thorburn's Inconel 625 UNS N06625 / EN 2.4856 is compliant with NACE MR0175-2009/ISO 15156-2009



## METALLIC EXPANSION JOINTS

Engineered Solutions for Pipe & Duct Motion



## Metallic Expansion Joints Catalog

Thorburn Flex manufactures a wide range of custom built metallic expansion joints which are used in industrial piping systems to accommodate thermal and mechanical movement. Metal bellows are designed to accommodate certain movements while minimizing the transfer of forces to sensitive components in the piping system. They are made of a series of one or more convolutions and are flexible enough to accept the axial, lateral, and angular deflections.

### Applications



Clean Power Generation



Petro-Chemical Processing



Hydro/Pyro Metallurgical Processing



## METALLIC HOSE ASSEMBLIES

Engineered Solutions For Pipe Motion



## Metallic Hose Assemblies Catalog

Thorburn Flex provides end-user engineered solutions for pipe motion. You specify the operating conditions and we will produce a custom metal hose assembly that will satisfy the operating conditions. Thorburn's metal hose assemblies may be exceptionally flexible, or you may need several hoses encapsulated in outer hose: a jacketed hose for heat exchange; an armoured hose; a hose to carry sensitive cables; an articulated robotic cover; an insulated hose; a colour coded hose. Our "Can-Do" design specialists are only a phone call away.

### Applications



Clean Gas Power Generation



Petro-Chemical Processing



Hydro/Pyro Metallurgical Processing

**THORBURN FLEX - Canada**  
 165 Oneida, Pointe-Claire, Quebec  
 Canada, H9R 1A9  
 Tel: +1-514-695-8710  
 Fax: +1-514-695-1321  
 sales@thorburnflex.com



ISCIR Romania | CNCAN Romania | EN 13480-2002 | HAF 604 China | TSG China  
 (CRN for all Canadian Provinces)

# Thorburn's Global Presence

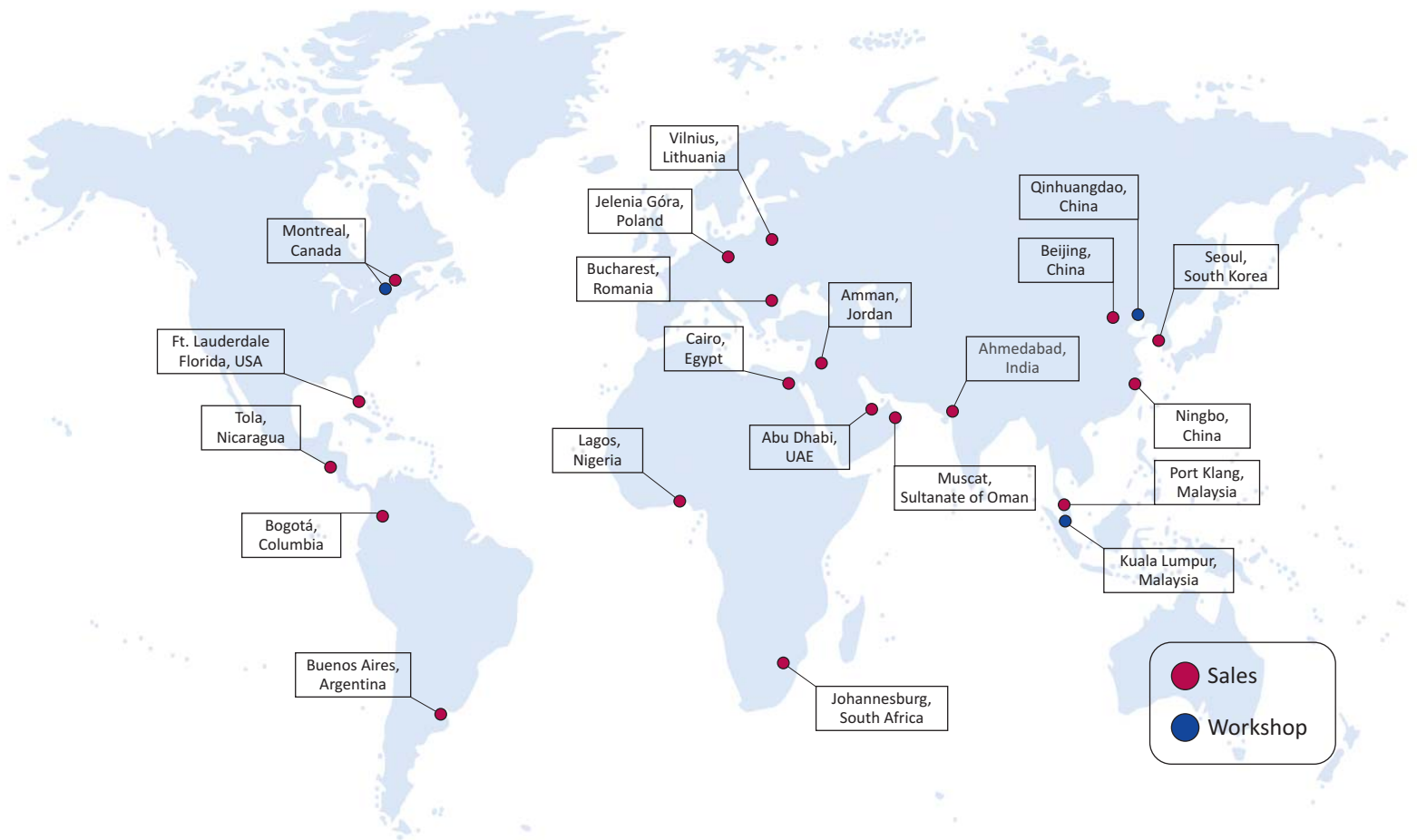

www.thorburnflex.com