

ThorburnFlex

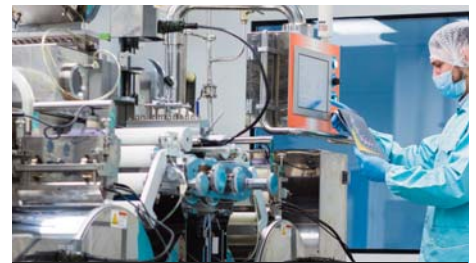

Petrochemical Processing



Pharmaceutical, Food & Beverage



Automotive & Aerospace

PTFE HOSE ASSEMBLIES

Engineered Solutions For Pipe Motion



www.thorburnflex.com



ThorburnFlex

Thorburn Flex is an innovative manufacturer of specialized engineered flexible piping systems (i.e. custom hose assemblies and expansion joints). Since 1954, Thorburn’s corporate mission evolution and business philosophy have been customer driven and targeted to select niche applications where Thorburn can achieve clear positions of sustainable technological and market share leadership. Thorburn is committed to a policy of continuous development and research to provide engineered solutions for pipe motion that set the industry standards for quality, safety, environmental protection, durability and value.



European
Conformity



ISO
9001



B31.1,
B31.3



ASME “NPT”
Sec. III Class 1



ASME “U”
Sec. VIII Div. 1



N285.0, B51
CGA CR96-001



97/23/EC
Module H



UL
536

ISCIR Romania | CNCAN Romania | EN 13480-2002 | HAF 604 China | TSG China

www.thorburnflex.com

Table Of Contents

Introduction

| | |
|-------------------------------------|---|
| Engineered PTFE Hose Assemblies | 4 |
| PTFE Hose Benefits and Capabilities | 6 |
| PTFE Hose Specifications | 7 |
| PTFE Hose Applications | 8 |

Smooth Bore PTFE Hose Assemblies

| | |
|------------------------------------|----|
| TS11/TS12 PTFE Hose Assemblies | 10 |
| TS Series PTFE Hose Couplings | 11 |
| TSX16 PTFE Hose Assemblies | 30 |
| TSX16 PTFE Hose Permanent Fittings | 31 |
| TSX17 PTFE Hose Assemblies | 36 |
| TSX17 PTFE Hose Permanent Fittings | 37 |
| TSX18 PTFE Hose Assemblies | 38 |
| TSX18 PTFE Hose Permanent Fittings | 39 |
| TR40 PTFE Hose Assemblies | 40 |
| TR40 PTFE Hose Permanent Fittings | 41 |

Convolute Bore PTFE Hose Assemblies

| | |
|--------------------------------|----|
| TC72/TC76 PTFE Hose Assemblies | 52 |
| TC85/TC87 PTFE Hose Assemblies | 53 |
| TC92/TC96 PTFE Hose Assemblies | 54 |
| TC97/TC98 PTFE Hose Assemblies | 55 |
| TC30 PTFE Hose Assemblies | 56 |
| TC31/TC32 PTFE Hose Assemblies | 57 |
| TC33/TC34 PTFE Hose Assemblies | 58 |
| TC60/TC61 PTFE Hose Assemblies | 59 |
| TC50/TC51 PTFE Hose Assemblies | 60 |
| TC Series PTFE Hose Couplings | 61 |

Accessories

| | |
|--|----|
| FJ72 Fry-Sil Fire Jacket & FJ73 Fry-Sil Tape | 72 |
| AF Series Ball Joint Armor-Flex Hose Guards | 73 |
| LS Series Lock Section Protective Covers | 74 |

Ordering Information

| | |
|-----------------------------------|----|
| How To Order PTFE Hose Assemblies | 76 |
|-----------------------------------|----|

Metal PTFE Hose Assemblies

| | |
|---|----|
| 58TT PTFE Chemical Transfer Hose Assemblies | 77 |
| 58TT PTFE Hose Permanent Fittings | 79 |
| 59TT PTFE High Pressure Swivel Flange Hose Assemblies | 80 |
| 60TT PTFE Sanitary Hose Assemblies | 81 |

Special Purpose PTFE Hose Assemblies

| | |
|---|-----|
| TS46/TS47 PTFE Hose Assemblies | 82 |
| TS46/TS47 PTFE Hose Field Attachable Fittings | 83 |
| TKP30 Potflex PTFE Dielectric Hose Assemblies | 92 |
| 559T(W) PTFE Hose Assemblies | 96 |
| 559T(W) PTFE Hose Permanent Fittings | 97 |
| TC818 PTFE Chlorine Transfer Hose Assemblies | 98 |
| TC818 PTFE Hose Permanent Fittings | 99 |
| Pigtail Compressed Gas Transfer Hose Assemblies | 100 |
| TS111/TS112 & TSX117 Pigtail PTFE Hose Assemblies | 102 |
| TSE110/TSE111 Pigtail ETFE Hose Assemblies | 103 |
| Sure Temp™ Electrically Heated Hose Assemblies | 106 |

Hose Couplings

| | |
|---|-----|
| (N)T11 Series - Remote Handling Quick Couplings | 112 |
| (N)T52 Series - Cryogenic Quick Couplings | 114 |
| MT3TL Series - Met-O-Seal | 116 |
| MTS4 Series - Met-O-Seal | 117 |
| (N)T92H Series - Dry Break Quick Couplings | 118 |
| Camlock Quick Couplings | 121 |
| Camlock Gaskets | 123 |
| Vacuseal Hose Couplings | 124 |
| Understanding Flanges | 125 |
| Sanitary Clamp Fittings | 126 |

Technical Data

| | |
|---|-----|
| Coupling Thread Types | |
| North American | 130 |
| British | 136 |
| German | 138 |
| French | 142 |
| Japanese | 143 |
| How to Measure Threads | 145 |
| Hose Assembly Installation Guide | 146 |
| Chemical Resistance Charts | 150 |

Engineered PTFE Hose Assemblies

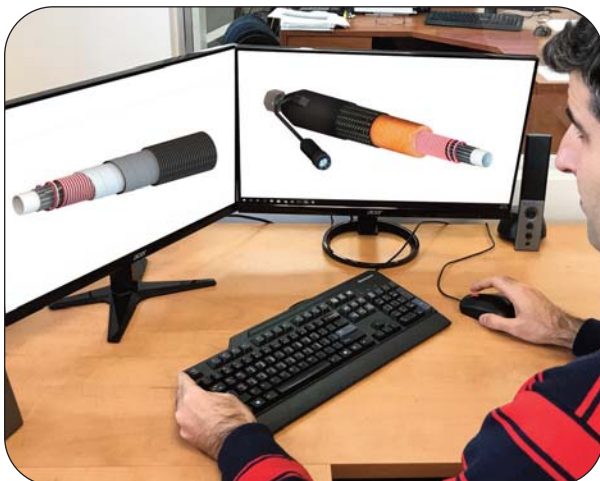
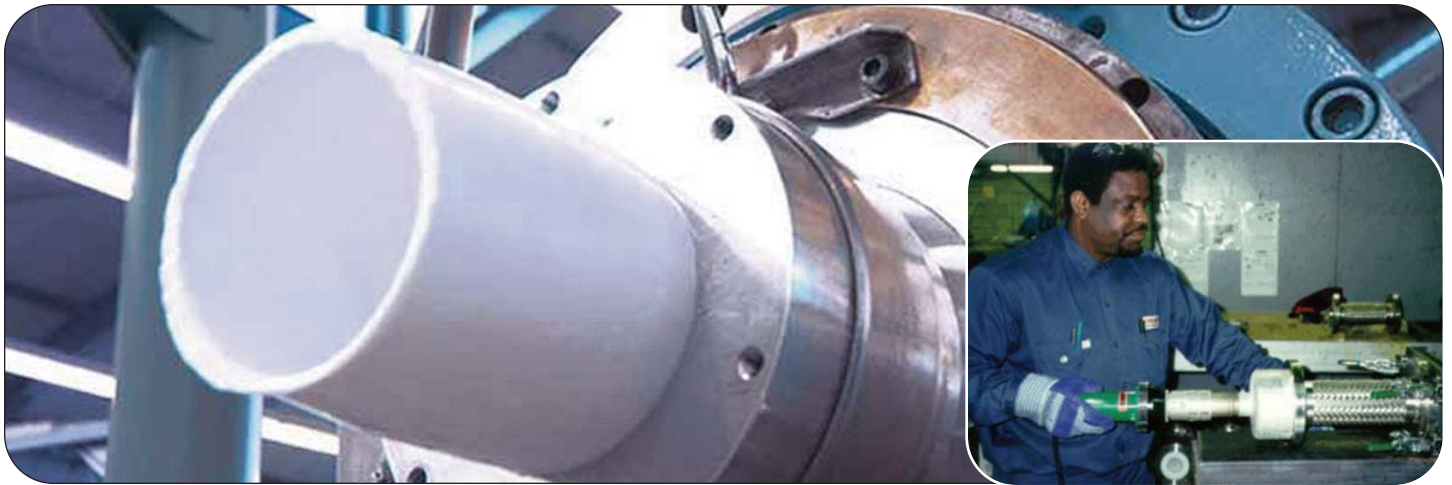

Thorburn's design team uses FEA & Solidworks to provide engineered pipe motion solutions

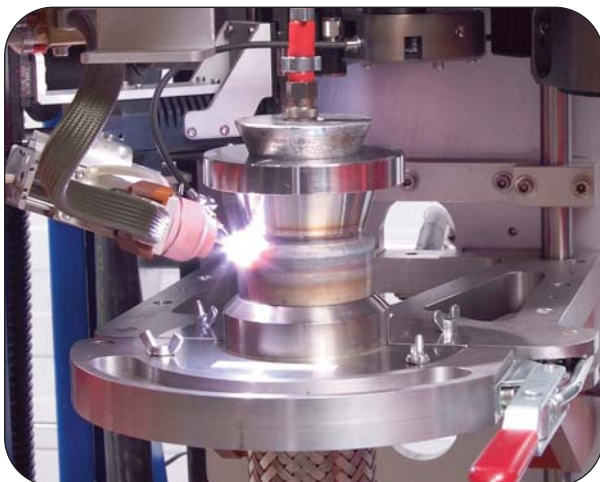

Automated fitting to end joint orbital welding

Engineering Capabilities & Experience

Thorburn's design engineering expertise is supported by advanced FEA software that offers powerful and complete solutions for both routine and sophisticated engineering problems. Thorburn's engineers can analyse and provide innovative solutions for pipe and duct motion problems including dynamic vibration, nonlinear static, linear static, thermal gradient through material wall thickness, acoustic impedance and fatigue using a common model data structure and integrated solver technology.

Design & Materials

- ASME Code Sections I, II, III, VIII, IX, B31.1 & B31.3
- ISO 10380 Corrugated Metal Hose & Hose Assemblies
- NACE MRO175-2009/ISO 15156-2009 compliance
- FEA - Finite Element Analysis

Welding and Fabrication Capabilities

- Arc, Pulse Arc, TIG, MIG, Core Wire
- Tube Welding, Track Welding, Automated Flame Cutting & Welding
- Rolls, Positioners, Turntables
- Automated Tube Welding DIN 6mm (1/4") to DIN 300mm (12")
- Hydro-Forming Convolutions DIN 25mm (1") to DIN 750mm (30")
- Mechanical Forming Convolutions DIN 6mm (1/4") to DIN 300mm (12")

NDT/NDE Programs & Design Verification Testing

- Weld X-Ray to 300KV-5MA / Welds Dye Penetrant to ASME Sec V
- Vacuum Testing 29.9" HG and Hydrostatic or Nitrogen Pressure Testing to 1,000 bar (15,000 psi)
- Impulse Testing to 680 bar (10,000 psi) at 204°C (400°F).
- Burst Testing up to 4,000 bar (60,000 psi)
- Pliability Fatigue & Deflection Testing ISO 10380:2012
- Seismic & Vibration Analysis in Acceptance with ASME Sec III
- Helium Mass Spectrometer Leak Testing

Fabrication Certification

- Welders and welding procedures: ASME Section VIII, IX, B31.1, B31.3, CSA B51 and Section III NPT (in progress)
- EN13480-2002: European Industrial Metallic Piping Standard & 97/23/EC (Pressure Equipment Directive)
- Canadian Gas Association (CGA) Certification: Standards CAN/CGA-8.1-M86, CGA96, UL96, UL536
- ISO 10380 Corrugated Metal Hose & Hose Assemblies
- Pressure Vessel Certification: CRN OH0012. All Canadian Provinces & Territories
- Monel Chlorine Transfer: Chlorine Institute Spec. 135-3
- Hose Assemblies Degreased, Cleaned and Capped for Oxygen or Chlorine Service

Quality Assurance Certification & Compliance

- CSA N299.1, ISO 9001, ASME B31.1, B31.3 Section III, ASME Section VIII, Div 1 "U", CSA B51, NCA 4000 NQA-1, CSA N285.0, ASME NPT, AS 9100 (in progress), ISO IEC 17025

Braided Reinforcement

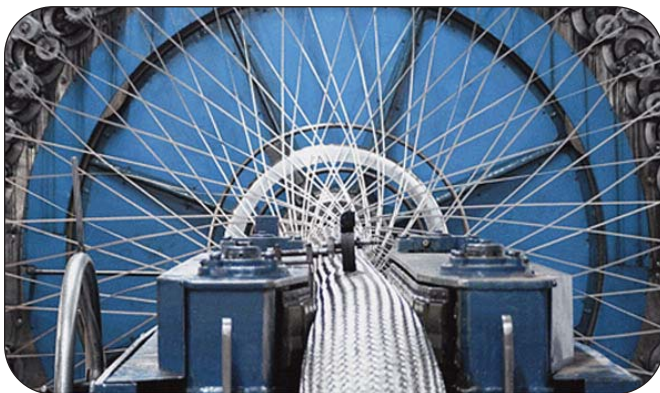

Thorburn uses a range of braiding machines (24, 36, 48, 64, 96 & 128 carriers), with the ability to produce top quality braid from 6mm (1/4") to 350mm (14")

The braid is the principal reinforcement component in our PTFE hoses. Our engineers design our braid's construction to optimize coverage, angle and thickness to maximize pressure containment in all our PTFE hose assemblies.

Thorburn's hose assemblies go through rigorous batch testing including burst, leak and hydrostatic testing to confirm theoretical calculations with actual test results.

After the attachment of the end fittings, each PTFE hose assembly is pressure tested to 1.5 times the design pressure and test certificates can be supplied.



- SAE J343
- ISO 1402
- ISO 6605
- ISO 1219-1
- DIN - 20024
- JBJ 8785
- JBJ/T7033-20017

Proof testing up to 6 hoses 1000 BAR



- SAE J343 - ISO 6803 - ISO 6605
- ISO 6772
- ISO 8032 (Half Omega)
- SAE J1405 - ISO 6802 (Omega)

Flex-impulse testing up to 700 BAR @ 150°C



- SAE J343
- ISO 1402
- DIN - 20024
- JBJ 8785

Burst testing up to 4000 BAR



- ISO 10380

Life cycle testing

PTFE Hose Benefits and Capabilities

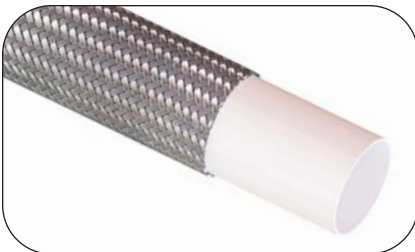

Smooth bore non-conductive PTFE tube

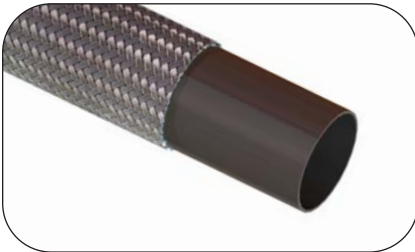

Smooth bore conductive PTFE tube



Convoluted bore non-conductive PTFE tube



Convoluted bore conductive PTFE tube

Chemical Inertness: Teflon will not decompose or break down in the most corrosive environments and it is inert to practically all commercial chemicals, acids, alcohols, coolants, elastomers, petroleum compounds, solvents, vinyls, synthetic lubricants and hydraulic fluids.

Temperature Resistant: Operating range of -100°F to 500°F at which hose stays flexible at low temperatures and strong at high temperatures.

Flex and Shock Resistance: Thorburn T-Flex is not affected by continuous flexing, vibration or impulse and it withstands alternating cold and heat cycling.

Low Friction: Liquids maintain a steady flow without clogging. Constant low pressure drop prevents deposits from accumulating on inside walls.

Moisture Resistant: Ideal for pneumatic systems requiring low dew point. No possibility of saturation or leakage.

Non-Contaminating: Will not contaminate the material, fluid or gas conducted - PTFE is FDA approved for food products, pharmaceuticals, etc.

Steam Compatibility: does not absorb moisture hot or cold-rated for steam to 250 psi (400°F)-has low volumetric expansion characteristics and is easy to clean and sterilize.

Light Weight: Easier to move, handle, install than rubber hose with a comparable burst pressure rating. Ideal as pigtail in gas handling and pneumatic systems where dew point must be low.

Resists Deterioration: Impervious to weather and can be stored for long periods without aging. Will not age during service.

Unlimited Life: Unmeasurable life expectancy when applied within its temperature and pressure ratings. Will not tear-up, eat-out, burn-up or wear-out.

Non-Adhesive: Handles substances such as adhesives, asphalt, dyes, grease, glue, latex, lacquers and paints. No carbon build up when used as a compressor discharge line.

Non-Conductive: Excellent dielectric properties. Ideal hose core for applications requiring electrical isolation.

PTFE Hose Specifications

Summary of Properties TFE, FEP, PFA

| Properties | TFE | FEP | PFA |
|---|------------------------------------|------------------------------------|------------------------------------|
| Color | Milky white | Clear blue tint | Clear blue tint |
| Continuous service Temperature | -250°C - +260°C -420°F - +500°F | -200°C - +204°C -300°F - +400°F | -200°C - +260°C -300°F - +500°F |
| Melting point | 327°C 621°F | -268°C - +271°C -487°F - +540°F | -302°C - +310°C -575°F - +590°F |
| Dielectric strength (ASTM D149) Short term 125 mil Volts/Mil 10 mil | 500 1400 | 500 1400 | 500 2000 |
| Dielectric constant (ASTM D140) 10 ² to 10 ⁶ Hz | 20 | 21 | 2.06 |
| Specific gravity (ASTM D792) | 2.10 - 2.20 | 2.10 - 2.10 | 2.10 - 2.20 |

| Properties | TFE | FEP | PFA |
|--|------------|------------|------------|
| Coefficient of friction dynamic | 10 | 0.25 | 0.20 |
| Tensile strength (PSI) | 2000-6000 | 2000 (Min) | 4000 (Min) |
| D638 elongation Min. (D638) | 200 | 250 | 250 |
| Flex modulus PSI x 10 ³ (D790) | 40-90 | 95 | 200 |
| Impact strength (Charpy, notched) Ft-Lb/In ² | 4 | - | - |
| Flammability | Non-flamm. | Non-flamm. | Non-flamm. |
| Water absorption % D570 | < .01 | < .01 | < .03 |

PTFE behavior Under Pressure & Temperature

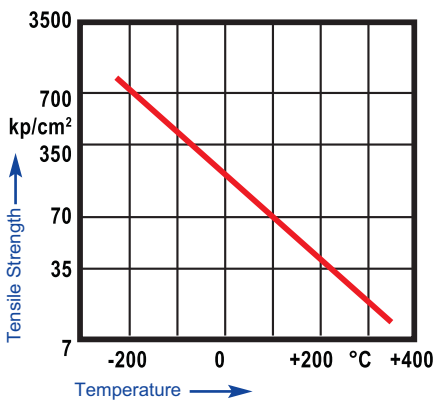

Tensile strength as a function of temperature

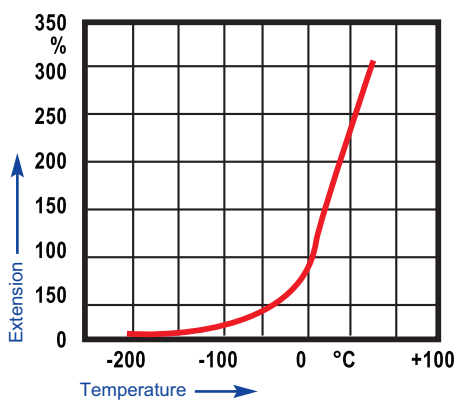

Extension as a function of temperature

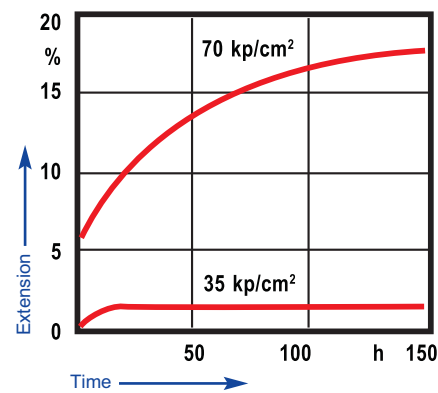

Deformation as a function of time under various pressure load applications

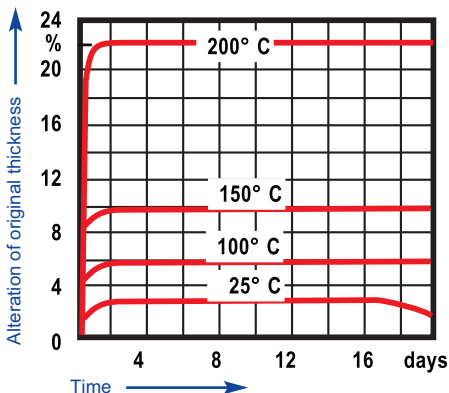

Deformation under application of pressure at 70 kp/cm² as a function of time at various temperatures

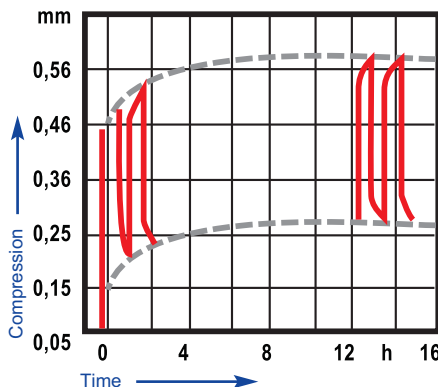

Deformation under alternating application and removal of load (70 kp/cm²) at a temperature of 25°C

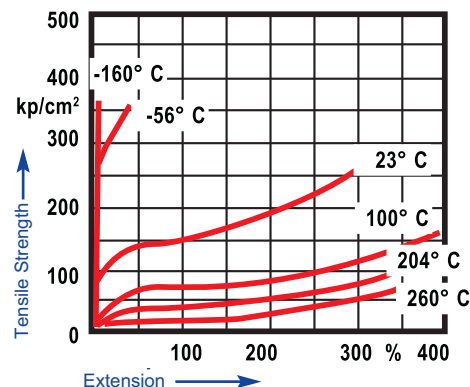

Tensile strength and extension as a function of temperature

PTFE Hose Applications

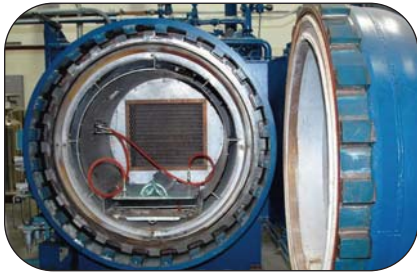

High temperature autoclaves

Aerosol Packaging For handling nitrous oxide, etc., as charging lines for pressurizing aerosol cans.

Air Conditioning Used to carry hot gases during dehydration of equipment prior to charging with refrigerant.

Autoclaves As a combination steam-vacuum line; typically furnished with an internal flat support spring where full vacuum (28") at 400° F is required.

Automotive Windshield forming; automotive automatic paint spray systems; reaction injection molding.



Automotive bonding

Bakery Industry As steam lines in various equipment such as on kettles for mixing batter; used with freon systems in quick-freeze operations.

Buses and Trucks Used as a compressor discharge line; also oil, fuel, water and air lines because the engine compartment temperatures can cause premature failure of rubber and other types of hoses.

Canning Industry Handles hot adhesives for the sealing process during the manufacturing of beer cans; also conducts cooling water to support racks to dispel heat from can body before it reaches soldering unit.



Canning machine

Cardboard Steam to the presses; also hot wax, as it is applied to the cardboard/paper.

Chemical Industry An all-purpose hose to handle most chemicals with the exception of molten alkali metals and molten sulfur. Teflon hose needs to be specially reinforced for applications, such as bromine and chlorine. One hose handles many chemicals; suitable for tank truck, as well as in plant use. Also used in-plant as a piping substitute.

Dies Used to convey dies and pigments, especially where a high degree of purity is required; Teflon's cleanability is a feature in this application.

Electronics Coolant lines for electronics gear, i.e. color television cameras and radar units.

Food Industry For recirculating hot oils and grease in deep fry systems; for conveying glutamates in the manufacture of corn syrup; for steam sealing small glassine containers such as individual portions of jelly; water supply to coffee urns. Teflon hose is an F.D.A. approved product.



Glass filling line machine

Gas Detection "Sniffer" lines to detect the presence of poisonous or corrosive gases.

Gas Transfer For filling cylinders as a replacement for copper tubing pigtails; in high pressure applications especially where temperature of a high degree of cleanliness is required.

Glass Bottle Industry Used to supply the air cylinders on the stackers which put the hot bottles in conveyer belts; also as gas lines to the burners and cooling water for the molds.



Gas detection sniffer



Hot glue machine

Glue Industry Used to convey hot melt adhesives to the dispensing guns or nozzles.



Insulation foam spraying

Hydraulic Carries hot oil and other lubricants without contamination; Teflon is especially good in applications where temperature, fluid viscosity or aging are factors.

Laundry or Dry Cleaning Steam lines on the laundry presses and hand irons.



Pharmaceutical processing

Marine Steam condensate lines; hydraulic hoses (catapults); fuel and oil lines in the engine compartment; hydraulic steering systems.

Paint Spray Used in airless paint systems to convey paint, lacquers and strong solvents. Paper/Cardboard/Fiberboard Industries Steam lines to the platens; wax coatings; steam hose on dry cans; chlorine (special) in the bleaching operation; black liquor lines; ideal rotary joint hose.

Photo/Photo Chemical Ideal for conveying light-sensitive chemicals especially where batch contamination is critical.



High purity processes

Platen Presses Hose conducts steam alternately with cold water to the multiple platens for manufacturing battery cases, styrene sheets, radio cases, records, plywood, fiberboard, tires, molded rubber, plastic toys, dinnerware, plastic helmets, tennis balls, golf balls and rubber mats.

Plating Industry Conveying steam to centrifugal dryers; acid transfer.

Power Houses On oil burners as oil feed lines.

Railroads Steam lines to tank car heaters.



Tire manufacturing

Shoe Manufacturing For transferring hot adhesives to cement the shoe soles; steam to molding presses.

Spray Systems Extermination systems for handling such things as carbon tetrachloride.

Stationary Power Plants Fuel, oil, air and hydraulic lines on jet engines.

Textile Industry Steam hoses on dryers/rotary joint connections.

Tire Manufacturing Steam lines to Bag-O-Matic type presses; also as steam lines used in recapping.

Toy Industry Used to convey hot plastisols to the "slush" molds. Urethane Foam Industry Conveying synthetic foam material under heat and high pressure.

TS11/TS12 PTFE Hose Assemblies



| TS11 (top) and TS12 Hose Assemblies |

APPLICATIONS:

- Transfer of compressed gases & steam
- High temperature hydraulic systems, fuel & lubricant handling
- Hot oils, solvents
- Viscous media such as paints & adhesives
- Pharmaceutical and beverage transfer
- Chemicals and acid transfer of all types – see chemical resistance charts

Thorburn's **TS11/TS12** is a flexible smooth bore PTFE hose assembly with high tensile stainless steel braided reinforcement that is designed for demanding applications in harsh environments that may involve pressure temperature and chemical extremes. TS11 is made from virgin extrusion PTFE for high purity applications. TS12 has an antistatic conductive carbon black added to the PTFE to dissipate an electrostatic charge in fuel, steam, or high flow-rate applications.

HOSE CONSTRUCTION:

TS11 Inner Core: Smooth extruded unpigmented PTFE

TS12 Inner Core: Smooth extruded unpigmented PTFE with added antistatic conductive carbon black

REINFORCEMENT: A580 type 304 (EN1.4301) high tensile stainless steel braid.

TEMPERATURE RANGE: -73°C to 260°C (-100°F to 500°F) – Consult Thorburn Flex for temperature adjusted pressure ratings.

STANDARDS:

- SAE 100R14,
- PTFE meets FDA 21 CFR 177.1550. & ISO 12086 Part 1.
- Meets Pharmacopoeia Class VI DIP & CIP.

AEROSPACE STANDARDS (on request):

- SAE AS1946, MIL-DTL-25579, MIL-DTL-27267

| Part Number | Nominal Size | | Nominal I.D. | | Nominal O.D. | | Operating Pressure | | Room Temp. Min. Burst | | Max. Continuous Length | | Min. Bend Radius | | Hose Weight | |
|-----------------|--------------|-------|--------------|------|--------------|------|--------------------|------|-----------------------|-------|------------------------|-----|------------------|------|-------------|-------|
| | DN | in | mm | in | mm | in | bar | psi | bar | psi | m | ft | mm | in | kg/m | lb/ft |
| TS11/TS12-3 | 7 | 3/16 | 3.5 | 0.14 | 5.8 | 0.23 | 206.8 | 3000 | 827.4 | 12000 | 61.0 | 200 | 50.8 | 2.0 | 0.071 | 0.048 |
| TS11/TS12-4 | 8 | 1/4 | 4.8 | 0.19 | 7.9 | 0.31 | 206.8 | 3000 | 827.4 | 12000 | 61.0 | 200 | 50.8 | 2.0 | 0.086 | 0.058 |
| TS11/TS12-5 | 9 | 5/16 | 6.4 | 0.25 | 9.6 | 0.38 | 206.8 | 3000 | 827.4 | 12000 | 76.2 | 250 | 76.2 | 3.0 | 0.116 | 0.078 |
| TS11/TS12-6 | 10 | 3/8 | 8.0 | 0.31 | 11.4 | 0.45 | 172.4 | 2500 | 689.5 | 10000 | 45.7 | 150 | 101.6 | 4.0 | 0.146 | 0.098 |
| TS11/TS12-6T* | 10 | 3/8 | 9.8 | 0.38 | 12.7 | 0.50 | 155.1 | 2250 | 620.5 | 9000 | 45.7 | 150 | 114.3 | 4.5 | 0.156 | 0.105 |
| TS11/TS12-8 | 15 | 1/2 | 10.4 | 0.41 | 14.0 | 0.55 | 137.9 | 2000 | 551.6 | 8000 | 30.5 | 100 | 132.1 | 5.2 | 0.188 | 0.126 |
| TS11/TS12-10 | 18 | 5/8 | 12.8 | 0.50 | 16.5 | 0.65 | 103.4 | 1500 | 344.7 | 5000 | 30.5 | 100 | 165.1 | 6.5 | 0.229 | 0.154 |
| TS11/TS12-12 | 20 | 3/4 | 16.2 | 0.64 | 19.8 | 0.78 | 82.7 | 1200 | 330.9 | 4800 | 22.9 | 75 | 195.6 | 7.7 | 0.283 | 0.190 |
| TS11/TS12-12T* | 20 | 3/4 | 19.1 | 0.75 | 22.6 | 0.89 | 75.8 | 1100 | 303.4 | 4400 | 22.9 | 75 | 208.3 | 8.2 | 0.314 | 0.211 |
| TS11/TS12-16 | 25 | 1 | 22.2 | 0.88 | 26.2 | 1.03 | 68.9 | 1000 | 303.4 | 4000 | 18.3 | 60 | 228.6 | 9.0 | 0.417 | 0.280 |
| TS11/TS12-16T* | 25 | 1 | 25.4 | 1.00 | 29.0 | 1.14 | 62.1 | 900 | 241.3 | 3500 | 18.3 | 60 | 254.0 | 10.0 | 0.479 | 0.322 |
| TS11/TS12-16Z** | 25 | 1 | 22.2 | 0.88 | 27.2 | 1.07 | 86.2 | 1250 | 344.7 | 5000 | 18.3 | 60 | 228.6 | 9.0 | 0.683 | 0.459 |
| TS11/TS12-20 | 32 | 1 1/4 | 28.6 | 1.13 | 33.5 | 1.32 | 55.2 | 800 | 220.6 | 3200 | 12.2 | 40 | 406.4 | 16.0 | 0.549 | 0.369 |

* T = True Bore (Thorburn Flex true bore fittings are non stock). ** Z = Double Braid

TS11/TS12 Series “TS” PTFE Hose Couplings

Male Pipe NPT Rigid

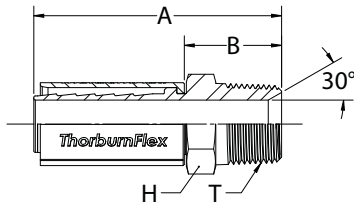

| Part Number | Nominal Hose I.D. | | Fitting Size | | Thread Size | A | | B Cutoff Allowance | | H Hex |
|--------------|-------------------|----|--------------|----|--------------|------|-----|--------------------|----|-------|
| | Inch | mm | Inch | mm | | Inch | mm | Inch | mm | |
| TS11-04-02MP | 1/4 | 6 | 1/8 | 3 | 1/8-27 | 2.05 | 52 | 0.96 | 24 | 7/16 |
| TS11-04-04MP | 1/4 | 6 | 1/4 | 6 | 1/4-18 | 2.33 | 59 | 1.14 | 29 | 9/16 |
| TS11-05-04MP | 5/16 | 8 | 1/4 | 6 | 1/4-18 | 2.64 | 67 | 1.21 | 31 | 9/16 |
| TS11-06-04MP | 3/8 | 10 | 1/4 | 6 | 1/4-18 | 2.96 | 75 | 1.21 | 31 | 9/16 |
| TS11-06-06MP | 3/8 | 10 | 3/8 | 10 | 3/8-18 | 2.96 | 75 | 1.21 | 31 | 11/16 |
| TS11-08-06MP | 1/2 | 12 | 3/8 | 10 | 3/8-18 | 3.00 | 76 | 1.26 | 32 | 11/16 |
| TS11-08-08MP | 1/2 | 12 | 1/2 | 12 | 1/2-14 | 2.80 | 71 | 1.45 | 37 | 7/8 |
| TS11-10-08MP | 5/8 | 16 | 1/2 | 12 | 1/2-14 | 2.96 | 75 | 1.50 | 38 | 7/8 |
| TS11-12-08MP | 3/4 | 20 | 1/2 | 12 | 1/2-14 | 3.35 | 85 | 1.63 | 41 | 7/8 |
| TS11-12-12MP | 3/4 | 20 | 3/4 | 20 | 3/4-14 | 3.23 | 82 | 1.51 | 38 | 1 1/8 |
| TS11-16-16MP | 1 | 25 | 1 | 25 | 1-11 1/2 | 3.70 | 94 | 1.58 | 40 | 1 3/8 |
| TS11-20-20MP | 1 1/4 | 30 | 1 1/4 | 30 | 1 1/4-11 1/2 | 4.41 | 112 | 2.09 | 53 | 1 3/4 |

Materials: 316 Stainless Steel, Brass Insert with Steel or Brass Ferrule.
Material ordering codes are found on Page 76

Male JIC 37° Rigid

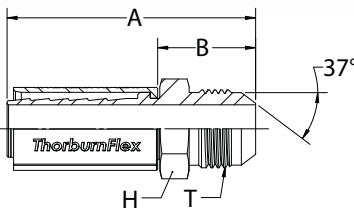

| Part Number | Nominal Hose I.D. | | Fitting Size | | Thread Size | A | | B Cutoff Allowance | | H Hex |
|--------------|-------------------|----|--------------|----|-------------|------|----|--------------------|----|-------|
| | Inch | mm | Inch | mm | | Inch | mm | Inch | mm | |
| TS11-04-04MJ | 1/4 | 6 | 1/4 | 6 | 7/16-20 | 2.16 | 55 | 1.14 | 28 | 1/2 |
| TS11-05-05MJ | 5/16 | 8 | 5/16 | 8 | 1/2-20 | 2.16 | 55 | 1.15 | 29 | 9/16 |
| TS11-06-06MJ | 3/8 | 10 | 3/8 | 10 | 9/16-18 | 2.16 | 55 | 1.15 | 29 | 11/16 |
| TS11-06-08MJ | 3/8 | 10 | 1/2 | 12 | 3/4-16 | 2.32 | 59 | 1.31 | 33 | 7/8 |
| TS11-08-08MJ | 1/2 | 12 | 1/2 | 12 | 3/4-16 | 2.80 | 71 | 1.36 | 35 | 7/8 |
| TS11-10-10MJ | 5/8 | 16 | 5/8 | 16 | 7/8-14 | 3.09 | 78 | 1.65 | 42 | 7/8 |
| TS11-12-12MJ | 3/4 | 20 | 3/4 | 20 | 1 1/16-12 | 3.41 | 87 | 1.70 | 43 | 1 1/8 |
| TS11-16-16MJ | 1 | 25 | 1 | 25 | 1 5/16-12 | 3.66 | 93 | 1.95 | 49 | 1 3/8 |

Materials: 316 Stainless Steel, Brass Insert with Steel or Brass Ferrule.
Material ordering codes are found on Page 76

TS11/TS12 Series “TS” PTFE Hose Couplings

Female JIC 37° Swivel

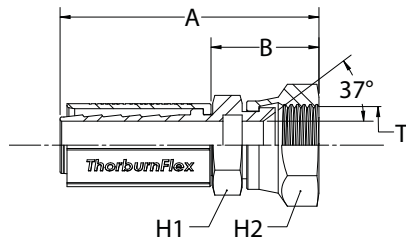

| Part Number | Nominal Hose I.D. | | Fitting Size | | Thread Size | A | | B Cutoff Allowance | | H2 Hex | H1 Hex |
|---------------|-------------------|----|--------------|----|-------------|------|-----|--------------------|----|---------|--------|
| | Inch | mm | Inch | mm | | Inch | mm | Inch | mm | Inch | Inch |
| TS11-04-04FJX | 1/4 | 6 | 1/4 | 6 | 7/16-20 | 2.13 | 54 | 1.04 | 26 | 3/8 | 9/16 |
| TS11-05-05FJX | 5/16 | 8 | 5/16 | 8 | 1/2-20 | 2.25 | 57 | 1.23 | 31 | 7/16 | 5/8 |
| TS11-06-06FJX | 3/8 | 10 | 3/8 | 10 | 9/16-18 | 2.24 | 56 | 1.22 | 30 | 1/2 | 11/16 |
| TS11-06-08FJX | 3/8 | 10 | 1/2 | 12 | 9/16-18 | 2.35 | 60 | 1.33 | 34 | 9/16 | 11/16 |
| TS11-08-08FJX | 1/2 | 12 | 1/2 | 12 | 3/4-16 | 2.76 | 70 | 1.32 | 33 | 11/16 | 7/8 |
| TS11-08-10FJX | 1/2 | 12 | 5/8 | 16 | 3/4-16 | 2.98 | 76 | 1.54 | 39 | 3/4 | 7/8 |
| TS11-10-10FJX | 5/8 | 16 | 5/8 | 16 | 7/8-14 | 3.40 | 85 | 1.60 | 41 | 13/16 | 1 |
| TS11-12-12FJX | 3/4 | 20 | 3/4 | 20 | 1 1/16-12 | 3.39 | 86 | 1.68 | 43 | 1 | 1 1/4 |
| TS11-16-16FJX | 1 | 25 | 1 | 25 | 1 5/16-12 | 3.63 | 92 | 1.92 | 49 | 1 1/4 | 1 1/2 |
| TS11-20-20FJX | 1 1/4 | 30 | 1 1/4 | 30 | 1 5/8-12 | 4.58 | 116 | 2.28 | 58 | 1 11/16 | 2 |

Materials: 316 Stainless Steel, Brass Insert with Carbon Steel Nut and Carbon Steel Ferrule, Brass Insert with Brass Nut and Carbon Steel Ferrule. Material ordering codes are found on Page 76

Female JIC 37° Swivel 45° Elbow

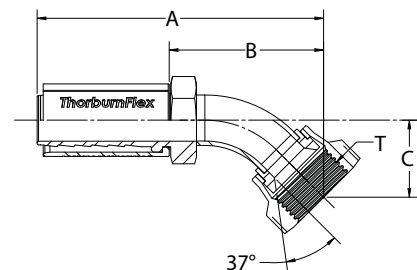

| Part Number | Nominal Hose I.D. | | Fitting Size | | Thread Size | A | | B Cutoff Allowance | | C Drop Dim. | | H1 Hex |
|-----------------|-------------------|----|--------------|----|-------------|------|-----|--------------------|-----|-------------|----|--------|
| | Inch | mm | Inch | mm | | Inch | mm | Inch | mm | Inch | mm | Inch |
| TS11-04-04FJX45 | 1/4 | 6 | 1/4 | 6 | 7/16-20 | 2.79 | 71 | 1.70 | 43 | 0.47 | 12 | 9/16 |
| TS11-06-06FJX45 | 3/8 | 10 | 3/8 | 10 | 9/16-18 | 3.12 | 79 | 2.10 | 53 | 0.56 | 14 | 11/16 |
| TS11-08-08FJX45 | 1/2 | 12 | 1/2 | 12 | 3/4-16 | 3.98 | 101 | 2.24 | 57 | 0.78 | 20 | 7/8 |
| TS11-12-12FJX45 | 3/4 | 20 | 3/4 | 20 | 1 1/16-12 | 4.62 | 117 | 2.91 | 74 | 1.06 | 27 | 1 1/4 |
| TS11-16-16FJX45 | 1 | 25 | 1 | 25 | 1 5/16-12 | 5.53 | 140 | 3.82 | 97 | 1.16 | 29 | 1 1/2 |
| TS11-20-20FJX45 | 1 1/4 | 30 | 1 1/4 | 30 | 1 5/8-12 | 7.94 | 202 | 5.64 | 143 | 1.38 | 35 | 2 |

Materials: 316 Stainless Steel, Brass Insert with Carbon Steel Nut and Carbon Steel Ferrule, Brass Insert with Brass Nut and Carbon Steel Ferrule. Material ordering codes are found on Page 76

TS11/TS12 Series “TS” PTFE Hose Couplings

Female JIC 37° Swivel 90° Elbow

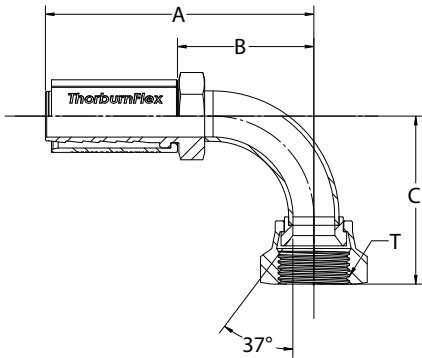

| Part Number | Nominal Hose I.D. | | Fitting Size | | Thread Size | A | | B Cutoff Allowance | | C Drop Dim. | | H1 Hex |
|-----------------|-------------------|----|--------------|----|-------------|------|-----|--------------------|----|-------------|----|--------|
| | Inch | mm | Inch | mm | | Inch | mm | Inch | mm | Inch | mm | |
| TS11-04-04FJX90 | 1/4 | 6 | 1/4 | 6 | 7/16-20 | 2.53 | 64 | 1.44 | 37 | 0.88 | 22 | 9/16 |
| TS11-06-06FJX90 | 3/8 | 10 | 3/8 | 10 | 9/16-18 | 2.91 | 74 | 1.89 | 48 | 1.13 | 29 | 11/16 |
| TS11-08-08FJX90 | 1/2 | 12 | 1/2 | 12 | 3/4-16 | 3.36 | 85 | 1.93 | 49 | 1.38 | 35 | 7/8 |
| TS11-12-12FJX90 | 3/4 | 20 | 3/4 | 20 | 1 1/16-12 | 4.52 | 115 | 2.81 | 71 | 1.82 | 46 | 1 1/4 |
| TS11-16-16FJX90 | 1 | 25 | 1 | 25 | 1 5/16-12 | 5.26 | 134 | 3.55 | 90 | 2.62 | 67 | 1 1/2 |
| TS11-20-20FJX90 | 1 1/4 | 30 | 1 1/4 | 30 | 1 5/8-12 | 5.50 | 140 | 3.75 | 95 | 3.50 | 89 | 2 |

Materials: 316 Stainless Steel, Brass Insert with Carbon Steel Nut and Carbon Steel Ferrule, Brass Insert with Brass Nut and Carbon Steel Ferrule. Material ordering codes are found on Page 76

Female JIC 37° Swivel 90° Long Elbow

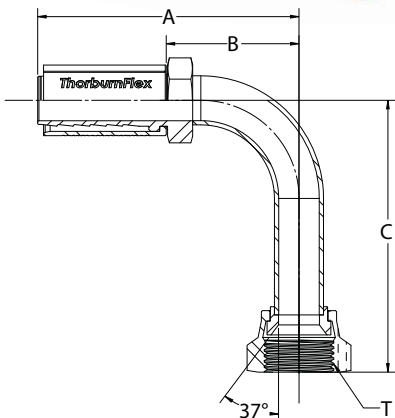

| Part Number | Nominal Hose I.D. | | Fitting Size | | Thread Size | A | | B Cutoff Allowance | | C Drop Dim. | | H1 Hex |
|------------------|-------------------|----|--------------|----|-------------|------|-----|--------------------|----|-------------|-----|--------|
| | Inch | mm | Inch | mm | | Inch | mm | Inch | mm | Inch | mm | |
| TS11-04-04FJX90L | 1/4 | 6 | 1/4 | 6 | 7/16-20 | 2.64 | 67 | 1.44 | 37 | 1.80 | 46 | 9/16 |
| TS11-06-06FJX90L | 3/8 | 10 | 3/8 | 10 | 9/16-18 | 3.01 | 76 | 1.81 | 46 | 2.18 | 55 | 11/16 |
| TS11-08-08FJX90L | 1/2 | 12 | 1/2 | 12 | 3/4-16 | 3.43 | 87 | 1.93 | 49 | 2.43 | 62 | 7/8 |
| TS11-12-12FJX90L | 3/4 | 20 | 3/4 | 20 | 1 1/16-12 | 4.50 | 114 | 2.81 | 71 | 3.73 | 95 | 1 1/4 |
| TS11-16-16FJX90L | 1 | 25 | 1 | 25 | 1 5/16-12 | 6.32 | 161 | 3.55 | 90 | 4.33 | 110 | 1 1/2 |
| TS11-20-20FJX90L | 1 1/4 | 30 | 1 1/4 | 30 | 1 5/8-12 | 6.51 | 165 | 3.80 | 97 | 4.75 | 134 | 2 |

Materials: 316 Stainless Steel, Brass Insert with Carbon Steel Nut and Carbon Steel Ferrule, Brass Insert with Brass Nut and Carbon Steel Ferrule. Material ordering codes are found on Page 76

TS11/TS12 Series “TS” PTFE Hose Couplings

Female Pipe Swivel

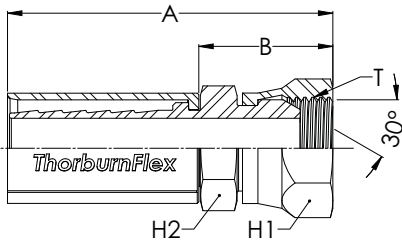

| Part Number | Nominal Hose I.D. | | Fitting Size | | Thread Size | A | | B Cutoff Allowance | | H2 Hex | H1 Hex |
|---------------|-------------------|----|--------------|----|-------------|------|-----|--------------------|----|--------|--------|
| | Inch | mm | Inch | mm | | Inch | mm | Inch | mm | | |
| TS11-04-04FPX | 1/4 | 6 | 1/4 | 6 | 1/4-18 | 2.44 | 62 | 1.24 | 31 | 9/16 | 11/16 |
| TS11-06-06FPX | 3/8 | 10 | 3/8 | 10 | 3/8-18 | 2.48 | 63 | 1.28 | 33 | 5/8 | 7/8 |
| TS11-08-08FPX | 1/2 | 12 | 1/2 | 12 | 1/2-14 | 2.85 | 72 | 1.35 | 34 | 3/4 | 1 |
| TS11-12-12FPX | 3/4 | 20 | 3/4 | 20 | 3/4-14 | 3.44 | 87 | 1.75 | 44 | 1 | 1 1/4 |
| TS11-16-16FPX | 1 | 25 | 1 | 25 | 1-11 1/2 | 4.10 | 104 | 1.90 | 48 | 1 3/16 | 1 3/8 |

Materials: 316 Stainless Steel, Brass Insert with Carbon Steel Nut and Carbon Steel Ferrule, Brass Insert with Brass Nut and Carbon Steel Ferrule. Material ordering codes are found on Page 76

Female “O”Seal™ Straight

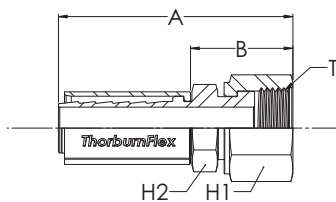

| Part Number | Nominal Hose I.D. | | Fitting Size | | Thread Size | A | | B Cutoff Allowance | | H2 Hex | H1 Hex |
|---------------|-------------------|----|--------------|----|-------------|------|-----|--------------------|----|---------|--------|
| | Inch | mm | Inch | mm | | Inch | mm | Inch | mm | | |
| TS11-04-04FOS | 1/4 | 6 | 1/4 | 6 | 9/16-18 | 2.32 | 59 | 1.53 | 39 | 9/16 | 11/16 |
| TS11-06-06FOS | 3/8 | 10 | 3/8 | 10 | 11/16-16 | 2.47 | 63 | 1.46 | 37 | 5/8 | 13/16 |
| TS11-08-08FOS | 1/2 | 12 | 1/2 | 12 | 13/16-16 | 3.10 | 79 | 1.66 | 42 | 3/4 | 15/16 |
| TS11-10-10FOS | 5/8 | 16 | 5/8 | 16 | 1-14 | 3.25 | 83 | 1.81 | 46 | 15/16 | 1 1/8 |
| TS11-10-12FOS | 5/8 | 16 | 3/4 | 20 | 1 3/16-12 | 3.25 | 83 | 1.81 | 46 | 15/16 | 1 3/8 |
| TS11-12-12FOS | 3/4 | 20 | 3/4 | 20 | 1 3/16-12 | 3.56 | 90 | 1.85 | 47 | 15/16 | 1 3/8 |
| TS11-16-16FOS | 1 | 25 | 1 | 25 | 1 7/16-12 | 4.01 | 102 | 2.30 | 58 | 1 3/8 | 1 5/8 |
| TS11-16-20FOS | 1 | 25 | 1 1/4 | 30 | 1 11/16-12 | 4.25 | 108 | 2.35 | 60 | 1 5/8 | 1 7/8 |
| TS11-20-20FOS | 1 1/4 | 30 | 1 1/4 | 30 | 1 11/16-12 | 4.75 | 121 | 2.40 | 61 | 1 11/16 | 1 7/8 |

Materials: 316 Stainless Steel. Material ordering codes are found on Page 76

TS11/TS12 Series “TS” PTFE Hose Couplings

Female “O”Seal™ Swivel 45° Elbow

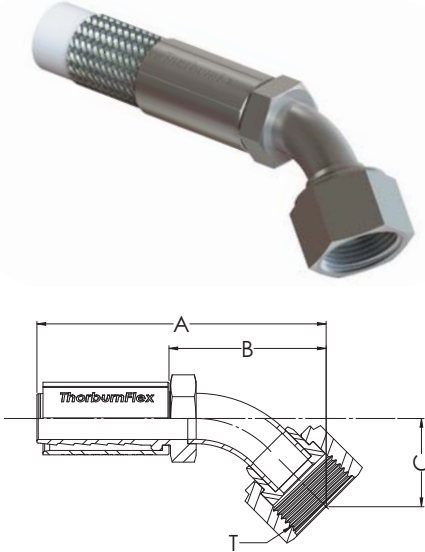

| Part Number | Nominal Hose I.D. | | Fitting Size | | Thread Size | A | | B Cutoff Allowance | | C Drop Dim. | | H1 Hex |
|-----------------|-------------------|----|--------------|----|-------------|------|-----|--------------------|----|-------------|----|--------|
| | Inch | mm | Inch | mm | | Inch | mm | Inch | mm | Inch | mm | |
| TS11-04-04FOS45 | 1/4 | 6 | 1/4 | 6 | 9/16-18 | 2.67 | 68 | 1.58 | 40 | 0.41 | 10 | 11/16 |
| TS11-06-06FOS45 | 3/8 | 10 | 3/8 | 10 | 11/16-16 | 2.95 | 75 | 1.93 | 49 | 0.56 | 14 | 13/16 |
| TS11-08-08FOS45 | 1/2 | 12 | 1/2 | 12 | 13/16-16 | 3.90 | 99 | 2.47 | 63 | 0.78 | 20 | 15/16 |
| TS11-12-12FOS45 | 3/4 | 20 | 3/4 | 20 | 1 3/16-12 | 4.57 | 116 | 2.86 | 73 | 1.06 | 27 | 1 3/8 |
| TS11-16-16FOS45 | 1 | 25 | 1 | 25 | 1 7/16-12 | 5.31 | 135 | 3.60 | 91 | 1.20 | 30 | 1 5/8 |

Materials: 316 Stainless Steel. Material ordering codes are found on Page 76

Female “O”Seal™ Swivel 90° Elbow

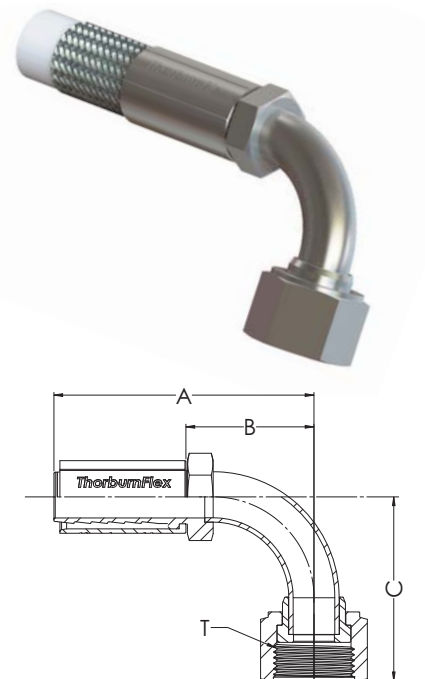

| Part Number | Nominal Hose I.D. | | Fitting Size | | Thread Size | A | | B Cutoff Allowance | | C Drop Dim. | | H1 Hex |
|-----------------|-------------------|----|--------------|----|-------------|------|-----|--------------------|----|-------------|----|--------|
| | Inch | mm | Inch | mm | | Inch | mm | Inch | mm | Inch | mm | |
| TS11-04-04FOS90 | 1/4 | 6 | 1/4 | 6 | 7/16-20 | 2.42 | 61 | 1.33 | 34 | 1.26 | 32 | 11/16 |
| TS11-06-06FOS90 | 3/8 | 10 | 3/8 | 10 | 1/2-20 | 2.83 | 71 | 1.81 | 46 | 1.51 | 38 | 13/16 |
| TS11-08-08FOS90 | 1/2 | 12 | 1/2 | 12 | 9/16-18 | 3.62 | 92 | 2.18 | 55 | 1.62 | 41 | 15/16 |
| TS11-10-10FOS90 | 5/8 | 16 | 5/8 | 16 | 3/4-16 | 3.67 | 93 | 2.23 | 57 | 1.88 | 47 | 1 1/8 |
| TS11-12-12FOS90 | 3/4 | 20 | 3/4 | 20 | 7/8-14 | 4.70 | 119 | 2.76 | 70 | 2.28 | 58 | 1 3/8 |
| TS11-16-16FOS90 | 1 | 25 | 1 | 25 | 1 1/16-12 | 5.20 | 132 | 3.54 | 90 | 2.78 | 71 | 1 5/8 |
| TS11-20-20FOS90 | 1 1/4 | 30 | 1 1/4 | 30 | 1 5/16-12 | 6.20 | 157 | 3.90 | 99 | 3.09 | 78 | 1 7/8 |

Materials: 316 Stainless Steel. Material ordering codes are found on Page 76

TS11/TS12 Series “TS” PTFE Hose Couplings

Female “O”Seal™ Swivel 90° Elbow Long Drop

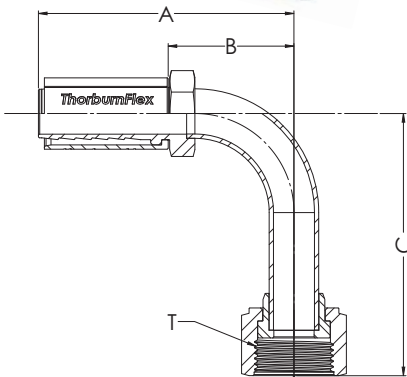

| Part Number | Nominal Hose I.D. | | Fitting Size | | Thread Size | A | | B Cutoff Allowance | | C Drop Dim. | | H1 Hex |
|------------------|-------------------|----|--------------|----|-------------|------|-----|--------------------|----|-------------|-----|--------|
| | Inch | mm | Inch | mm | | Inch | mm | Inch | mm | Inch | mm | Inch |
| TS11-04-04FOS90L | 1/4 | 6 | 1/4 | 6 | 9/16-18 | 2.42 | 61 | 1.33 | 34 | 1.80 | 46 | 11/16 |
| TS11-06-06FOS90L | 3/8 | 10 | 3/8 | 10 | 11/16-16 | 2.83 | 72 | 1.81 | 46 | 2.13 | 54 | 13/16 |
| TS11-08-08FOS90L | 1/2 | 12 | 1/2 | 12 | 13/16-16 | 3.62 | 92 | 2.18 | 55 | 2.51 | 64 | 15/16 |
| TS11-10-10FOS90L | 5/8 | 16 | 5/8 | 16 | 1-14 | 3.67 | 93 | 2.23 | 57 | 2.76 | 70 | 1 1/8 |
| TS11-12-12FOS90L | 3/4 | 20 | 3/4 | 20 | 1 3/16-12 | 4.47 | 114 | 2.76 | 70 | 3.78 | 96 | 1 3/8 |
| TS11-16-16FOS90L | 1 | 25 | 1 | 25 | 1 7/16-12 | 5.25 | 133 | 3.64 | 92 | 4.50 | 114 | 1 1/2 |

Materials: 316 Stainless Steel. Material ordering codes are found on Page 76

Female SAE 45° Swivel

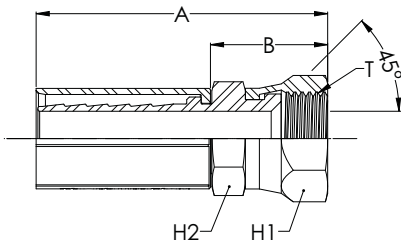

| Part Number | Nominal Hose I.D. | | Fitting Size | | Thread Size | A | | B Cutoff Allowance | | H2 Hex | H1 Hex |
|---------------|-------------------|----|--------------|----|-------------|------|----|--------------------|----|--------|--------|
| | Inch | mm | Inch | mm | | Inch | mm | Inch | mm | Inch | Inch |
| TS11-06-06FSX | 3/8 | 10 | 3/8 | 10 | 5/8-18 | 2.24 | 57 | 1.22 | 31 | 5/8 | 3/4 |
| TS11-12-12FSX | 3/4 | 20 | 3/4 | 20 | 1 1/16-14 | 3.39 | 86 | 1.68 | 43 | 1 | 1 1/4 |

Materials: 316 Stainless Steel, Brass Insert with Carbon Steel Nut and Carbon Steel Ferrule, Brass Insert with Brass Nut and Carbon Steel Ferrule. Material ordering codes are found on Page 76

TS11/TS12 Series “TS” PTFE Hose Couplings

Female SAE 45° Swivel 45° Elbow



| Part Number | Nominal Hose I.D. | | Fitting Size | | Thread Size | A | | B Cutoff Allowance | | C Drop Dim. | | H1 Hex |
|-----------------|-------------------|----|--------------|----|-------------|------|-----|--------------------|----|-------------|----|--------|
| | Inch | mm | Inch | mm | | Inch | mm | Inch | mm | Inch | mm | |
| TS11-06-06FSX45 | 3/8 | 10 | 3/8 | 10 | 5/8-18 | 3.30 | 84 | 2.10 | 53 | 1.19 | 30 | 3/4 |
| TS11-12-12FSX45 | 3/4 | 20 | 3/4 | 20 | 1 1/16-14 | 4.60 | 117 | 2.91 | 74 | 1.82 | 46 | 1 1/4 |

Materials: 316 Stainless Steel, Brass Insert with Carbon Steel Nut and Carbon Steel Ferrule, Brass Insert with Brass Nut and Carbon Steel Ferrule. Material ordering codes are found on Page 76

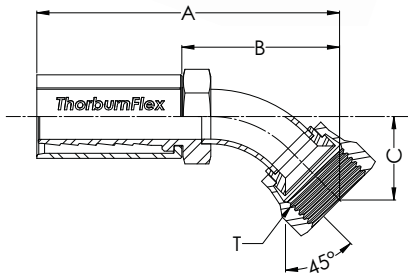

Female SAE 45° Swivel 90° Elbow



| Part Number | Nominal Hose I.D. | | Fitting Size | | Thread Size | A | | B Cutoff Allowance | | C Drop Dim. | | H1 Hex |
|-----------------|-------------------|----|--------------|----|-------------|------|-----|--------------------|----|-------------|----|--------|
| | Inch | mm | Inch | mm | | Inch | mm | Inch | mm | Inch | mm | |
| TS11-06-06FSX90 | 3/8 | 10 | 3/8 | 10 | 5/8-18 | 2.91 | 74 | 1.81 | 46 | 0.39 | 10 | 3/4 |
| TS11-12-12FSX90 | 3/4 | 20 | 3/4 | 20 | 1 1/16-14 | 4.52 | 115 | 2.81 | 71 | 0.78 | 20 | 1 1/4 |

Materials: 316 Stainless Steel, Brass Insert with Carbon Steel Nut and Carbon Steel Ferrule, Brass Insert with Brass Nut and Carbon Steel Ferrule. Material ordering codes are found on Page 76

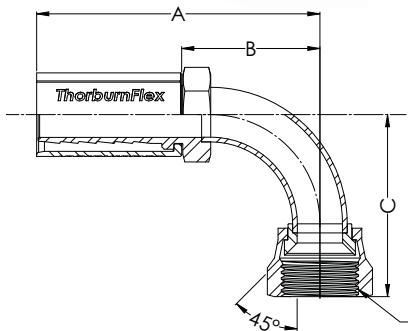

TS11/TS12 Series “TS” PTFE Hose Couplings

Compression Fitting Swagelok™ Compatible Nut & Ferrule

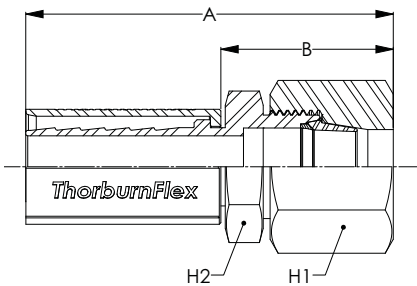

| Part Number | Nominal Hose I.D. | | Fitting Size | | Thread Size | A | | B Cutoff Allowance | | H2 Hex | H1 Hex |
|--------------|-------------------|----|--------------|----|-------------|------|----|--------------------|----|--------|--------|
| | Inch | mm | Inch | mm | | Inch | mm | Inch | mm | Inch | Inch |
| TS11-04-04CF | 1/4 | 6 | 1/4 | 6 | N/A | 1.70 | 43 | 0.50 | 12 | 1/2 | 9/16 |
| TS11-05-04CF | 5/16 | 8 | 1/4 | 6 | N/A | 1.70 | 43 | 0.50 | 12 | 1/2 | 9/16 |
| TS11-06-06CF | 3/8 | 10 | 3/8 | 10 | N/A | 1.83 | 46 | 0.63 | 16 | 5/8 | 11/16 |
| TS11-08-08CF | 1/2 | 12 | 1/2 | 12 | N/A | 2.20 | 56 | 0.70 | 18 | 13/16 | 7/8 |
| TS11-12-12CF | 3/4 | 20 | 3/4 | 20 | N/A | 2.44 | 62 | 0.75 | 19 | 1 1/8 | 1 1/8 |
| TS11-16-16CF | 1 | 25 | 1 | 25 | N/A | 2.69 | 68 | 1.00 | 25 | 1 3/8 | 1 1/8 |

Materials: 316 Stainless Steel. Material ordering codes are found on Page 76. Swagelok™ is a Registered Trademark of Crawford Company

Tube Stub

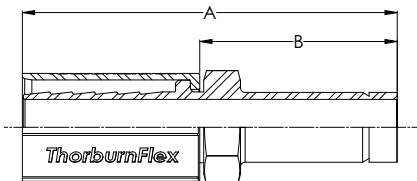

| Part Number | Nominal Hose I.D. | | Tube OD | | A | | B Cutoff Allowance | |
|--------------|-------------------|----|---------|----|------|----|--------------------|----|
| | Inch | mm | Inch | mm | Inch | mm | Inch | mm |
| TS11-03-02TE | 5/16 | 8 | 1/8 | 3 | 2.11 | 54 | 0.88 | 22 |
| TS11-04-04TE | 1/4 | 6 | 1/4 | 6 | 1.99 | 51 | 1.06 | 27 |
| TS11-05-04TE | 5/16 | 8 | 1/4 | 6 | 2.24 | 57 | 1.06 | 27 |
| TS11-06-06TE | 3/8 | 10 | 3/8 | 10 | 3.08 | 78 | 1.10 | 28 |
| TS11-08-08TE | 1/2 | 12 | 1/2 | 12 | 3.08 | 78 | 1.44 | 37 |
| TS11-12-12TE | 3/4 | 20 | 3/4 | 20 | 3.53 | 90 | 1.74 | 44 |
| TS11-16-16TE | 1 | 25 | 1 | 25 | 3.78 | 96 | 2.00 | 50 |

Materials: 316 Stainless Steel. Material ordering codes are found on Page 76

TS11/TS12 Series “TS” PTFE Hose Couplings

Male MVS



| Part Number | Nominal Hose I.D. | | Fitting Size | | Thread Size | A | | B Cutoff Allowance | | H1 Hex |
|---------------|-------------------|----|--------------|----|-------------|------|----|--------------------|----|--------|
| | Inch | mm | Inch | mm | | Inch | mm | Inch | mm | |
| TS11-04-04MVS | 1/4 | 6 | 1/4 | 6 | 9/16-18 | 2.20 | 56 | 1.00 | 25 | 3/4 |
| TS11-06-06MVS | 3/8 | 10 | 3/8 | 10 | 7/8-14 | 2.20 | 56 | 1.00 | 25 | 1 1/16 |
| TS11-08-08MVS | 1/2 | 12 | 1/2 | 12 | 7/8-14 | 2.57 | 65 | 1.07 | 27 | 1 1/16 |

Materials: 316 Stainless Steel. Material ordering codes are found on Page 76. Metal-To-Metal Seal for high purity, vacuum or positive pressure service. See Page 124 for details.

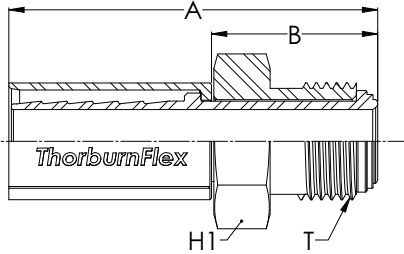

Female FVS



| Part Number | Nominal Hose I.D. | | Fitting Size | | Thread Size | A | | B Cutoff Allowance | | H1 Hex |
|---------------|-------------------|----|--------------|----|-------------|------|----|--------------------|----|--------|
| | Inch | mm | Inch | mm | | Inch | mm | Inch | mm | |
| TS11-04-04FVS | 1/4 | 6 | 1/4 | 6 | 9/16-18 | 2.27 | 58 | 1.07 | 27 | 3/4 |
| TS11-06-08FVS | 3/8 | 10 | 1/2 | 12 | 7/8-14 | 2.59 | 66 | 1.19 | 30 | 1 1/16 |
| TS11-08-08FVS | 1/2 | 12 | 1/2 | 12 | 7/8-14 | 2.69 | 68 | 1.19 | 30 | 1 1/16 |

Materials: 316 Stainless Steel. Material ordering codes are found on Page 763. Metal-To-Metal Seal for high purity, vacuum or positive pressure service. See Page 124 for details.

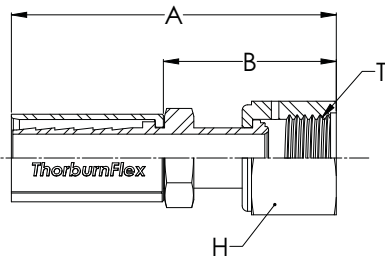

TS11/TS12 Series “TS” PTFE Hose Couplings

Female BSP Swivel

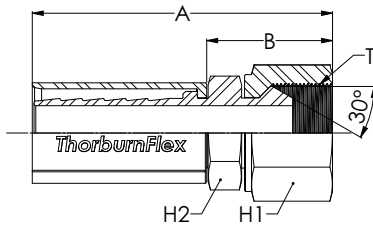

| Part Number | Nominal Hose I.D. | | Fitting Size | | Thread Size | A | | B Cutoff Allowance | | H2 Hex | H1 Hex |
|-----------------|-------------------|----|--------------|----|-------------|------|----|--------------------|----|--------|---------|
| | Inch | mm | Inch | mm | | Inch | mm | Inch | mm | | |
| TS11-04-04FBSPX | 1/4 | 6 | 1/4 | 6 | 1/4-18 | 2.28 | 58 | 1.18 | 30 | 3/4 | 1/2 |
| TS11-06-06FBSPX | 3/8 | 10 | 3/8 | 10 | 3/8-18 | 2.40 | 61 | 1.23 | 31 | 7/8 | 5/8 |
| TS11-08-08FBSPX | 1/2 | 12 | 1/2 | 12 | 1/2-14 | 2.85 | 72 | 1.35 | 34 | 1 | 1 13/16 |
| TS11-12-12FBSPX | 3/4 | 20 | 3/4 | 20 | 3/4-14 | 3.44 | 87 | 1.75 | 44 | 1 1/4 | 1 1/16 |
| TS11-16-16FBSPX | 1 | 25 | 1 | 25 | 1-11 | 3.54 | 90 | 1.83 | 46 | 1 1/2 | 1 3/8 |

Materials: 316 Stainless Steel. Material ordering codes are found on Page 76

Female BSP Swivel 90° Elbow

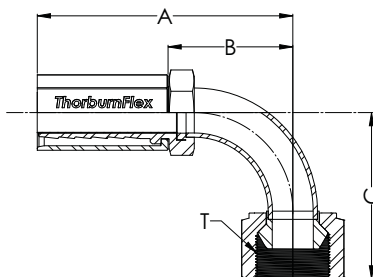

| Part Number | Nominal Hose I.D. | | Fitting Size | | Thread Size | A | | B Cutoff Allowance | | C Drop Dim. | | H1 Hex |
|-------------------|-------------------|----|--------------|----|-------------|------|-----|--------------------|-----|-------------|----|--------|
| | Inch | mm | Inch | mm | | Inch | mm | Inch | mm | Inch | mm | |
| TS11-04-04FBSPX90 | 1/4 | 6 | 1/4 | 6 | 1/4-19 | 2.54 | 65 | 1.45 | 37 | 1.26 | 32 | 3/4 |
| TS11-06-06FBSPX90 | 3/8 | 10 | 3/8 | 10 | 3/8-19 | 2.75 | 70 | 1.73 | 44 | 1.27 | 33 | 7/8 |
| TS11-08-08FBSPX90 | 1/2 | 12 | 1/2 | 12 | 1/2-14 | 3.43 | 87 | 1.93 | 49 | 1.69 | 43 | 1 |
| TS11-12-12FBSPX90 | 3/4 | 20 | 3/4 | 20 | 3/4-14 | 4.50 | 114 | 2.81 | 71 | 2.20 | 56 | 1 1/4 |
| TS11-16-16FBSPX90 | 1 | 25 | 1 | 25 | 1-11 | 5.63 | 143 | 3.93 | 100 | 2.69 | 68 | 1 1/2 |

Materials: 316 Stainless Steel. Material ordering codes are found on Page 76

TS11/TS12 Series “TS” PTFE Hose Couplings

Male Inverted Swivel-Straight

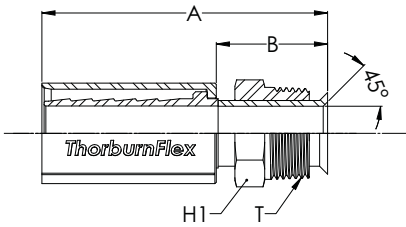

| Part Number | Nominal Hose I.D. | | Fitting Size | | Thread Size | A | | B Cutoff Allowance | | H Hex |
|---------------|-------------------|----|--------------|----|-------------|------|----|--------------------|----|--------|
| | Inch | mm | Inch | mm | | Inch | mm | Inch | mm | |
| TS11-04-04MIS | 1/4 | 6 | 1/4 | 6 | 7/16-24 | 2.70 | 69 | 1.50 | 38 | 7/16 |
| TS11-05-05MIS | 5/16 | 8 | 5/16 | 8 | 1/2-20 | 2.77 | 70 | 1.57 | 40 | 1/2 |
| TS11-05-06MIS | 5/16 | 8 | 3/8 | 10 | 1/2-20 | 2.77 | 70 | 1.57 | 40 | 1/2 |
| TS11-06-06MIS | 3/8 | 10 | 3/8 | 10 | 5/8-18 | 2.77 | 70 | 1.57 | 40 | 5/8 |
| TS11-08-08MIS | 1/2 | 12 | 1/2 | 12 | 3/4-18 | 3.13 | 80 | 1.63 | 41 | 3/4 |
| TS11-10-10MIS | 5/8 | 16 | 5/8 | 16 | 7/8-18 | 3.22 | 82 | 1.75 | 44 | 7/8 |
| TS11-12-12MIS | 3/4 | 20 | 3/4 | 20 | 1 1/16-16 | 3.44 | 87 | 1.75 | 44 | 1 1/16 |

Materials: 316 Stainless Steel, Brass Insert with Steel or Brass Ferrule.
Material ordering codes are found on Page 76

Male Inverted Swivel 45° Elbow

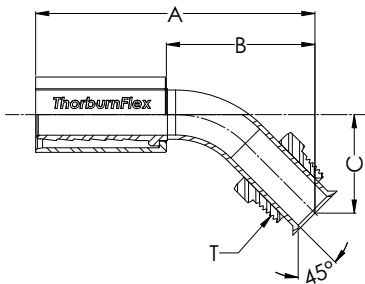

| Part Number | Nominal Hose I.D. | | Fitting Size | | Thread Size | A | | B Cutoff Allowance | | C Drop Dim. | | H1 Hex |
|-----------------|-------------------|----|--------------|----|-------------|------|-----|--------------------|----|-------------|----|--------|
| | Inch | mm | Inch | mm | | Inch | mm | Inch | mm | Inch | mm | |
| TS11-04-04MIS45 | 1/4 | 6 | 1/4 | 6 | 7/16-24 | 2.70 | 69 | 1.50 | 38 | 0.63 | 16 | 7/16 |
| TS11-05-05MIS45 | 5/16 | 8 | 5/16 | 8 | 1/2-20 | 3.08 | 78 | 1.88 | 48 | 0.71 | 18 | 1/2 |
| TS11-06-06MIS45 | 3/8 | 10 | 3/8 | 10 | 5/8-18 | 3.14 | 80 | 1.94 | 49 | 0.96 | 24 | 5/8 |
| TS11-08-08MIS45 | 1/2 | 12 | 1/2 | 12 | 3/4-18 | 3.63 | 92 | 2.13 | 54 | 0.90 | 23 | 3/4 |
| TS11-10-10MIS45 | 5/8 | 16 | 5/8 | 16 | 7/8-18 | 4.13 | 105 | 2.63 | 67 | 1.02 | 43 | 7/8 |
| TS11-12-12MIS45 | 3/4 | 20 | 3/4 | 20 | 1 1/16-16 | 4.51 | 115 | 2.82 | 72 | 1.15 | 29 | 1 1/16 |

Materials: 316 Stainless Steel, Brass Insert with Steel or Brass Ferrule.
Material ordering codes are found on Page 76

TS11/TS12 Series “TS” PTFE Hose Couplings

Male Inverted Swivel 90° Elbow

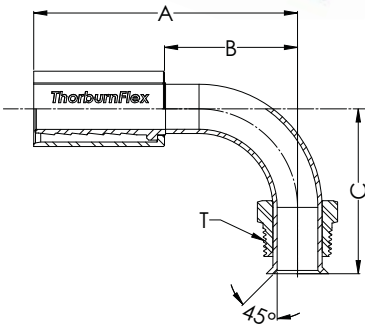

| Part Number | Nominal Hose I.D. | | Fitting Size | | Thread Size | A | | B Cutoff Allowance | | C Drop Dim. | | H1 Hex |
|-----------------|-------------------|----|--------------|----|-------------|------|-----|--------------------|----|-------------|----|--------|
| | Inch | mm | Inch | mm | | Inch | mm | Inch | mm | Inch | mm | |
| TS11-04-04MIS90 | 1/4 | 6 | 1/4 | 6 | 7/16-24 | 2.39 | 61 | 1.19 | 30 | 1.19 | 30 | 7/16 |
| TS11-05-05MIS90 | 5/16 | 8 | 5/16 | 8 | 1/2-20 | 2.58 | 66 | 1.38 | 35 | 1.65 | 42 | 1/2 |
| TS11-05-06MIS90 | 5/16 | 8 | 3/8 | 10 | 1/2-20 | 2.64 | 67 | 1.44 | 37 | 1.65 | 42 | 1/2 |
| TS11-06-06MIS90 | 3/8 | 10 | 3/8 | 10 | 5/8-18 | 2.64 | 67 | 1.44 | 37 | 1.70 | 43 | 5/8 |
| TS11-08-08MIS90 | 1/2 | 12 | 1/2 | 12 | 3/4-18 | 3.00 | 76 | 1.50 | 38 | 1.87 | 43 | 3/4 |
| TS11-10-10MIS90 | 5/8 | 16 | 5/8 | 16 | 7/8-18 | 4.19 | 106 | 2.50 | 64 | 2.18 | 55 | 7/8 |
| TS11-12-12MIS90 | 3/4 | 20 | 3/4 | 20 | 1 1/16-16 | 4.26 | 108 | 2.57 | 65 | 2.51 | 64 | 1 1/16 |

Materials: 316 Stainless Steel, Brass Insert with Steel or Brass Ferrule.
Material ordering codes are found on Page 76

Mini Sanitary Flange



| Part Number | Nominal Hose I.D. | | Nominal Flange Size | | A | | B Cutoff Allowance | | Flange I.D. | | Flange O.D. | |
|---------------|-------------------|----|---------------------|----|------|----|--------------------|----|-------------|----|-------------|----|
| | Inch | mm | Inch | mm | Inch | mm | Inch | mm | Inch | mm | Inch | mm |
| TS11-08-08MSF | 1/2 | 12 | 1/2 | 12 | 3.12 | 79 | 1.62 | 41 | 0.37 | 13 | 0.98 | 25 |
| TS11-12-12MSF | 3/4 | 20 | 3/4 | 20 | 3.31 | 84 | 1.62 | 41 | 0.62 | 19 | 0.98 | 25 |

Materials: 316 Stainless Steel. Material ordering codes are found on Page 76

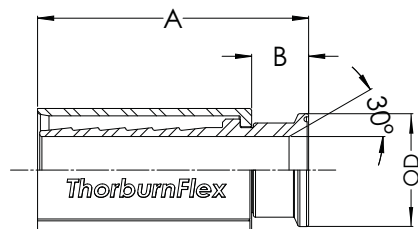

TS11/TS12 Series “TS” PTFE Hose Couplings

Tri-Clamp Sanitary Flange

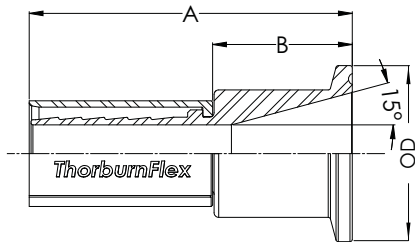

| Part Number | Nominal Hose I.D. | | Nominal Flange Size | | A | | B Cutoff Allowance | | Flange I.D. | | Flange O.D. | |
|----------------|-------------------|----|---------------------|----|------|-----|--------------------|----|-------------|----|-------------|----|
| | Inch | mm | Inch | mm | Inch | mm | Inch | mm | Inch | mm | Inch | mm |
| TS11-08-16TSFA | 1/2 | 12 | 1 | 25 | 3.22 | 82 | 1.72 | 44 | 0.87 | 22 | 1.34 | 50 |
| TS11-12-16TSFA | 3/4 | 20 | 1 | 25 | 3.41 | 87 | 1.72 | 44 | 0.87 | 22 | 1.34 | 50 |
| TS11-16-16TSFA | 1 | 25 | 1 | 25 | 3.92 | 100 | 1.72 | 44 | 0.87 | 22 | 1.34 | 50 |
| TS11-08-16TSFB | 1/2 | 12 | 1 | 25 | 3.22 | 82 | 1.72 | 44 | 0.87 | 22 | 1.98 | 50 |
| TS11-12-16TSFB | 3/4 | 20 | 1 | 25 | 3.41 | 87 | 1.72 | 44 | 0.87 | 22 | 1.98 | 50 |
| TS11-16-16TSFB | 1 | 25 | 1 | 25 | 3.92 | 100 | 1.72 | 44 | 0.87 | 22 | 1.98 | 50 |
| TS11-08-24TSFB | 1/2 | 12 | 1 1/2 | 40 | 3.34 | 85 | 1.97 | 50 | 1.37 | 35 | 1.98 | 50 |
| TS11-12-24TSFB | 3/4 | 20 | 1 1/2 | 40 | 3.66 | 93 | 1.97 | 50 | 1.37 | 35 | 1.98 | 50 |
| TS11-16-24TSFB | 1 | 25 | 1 1/2 | 40 | 4.17 | 106 | 1.97 | 50 | 1.37 | 35 | 1.98 | 50 |

Materials: 316 Stainless Steel. Material ordering codes are found on Page 76

Tri-Clamp Sanitary Flange Encapsulated

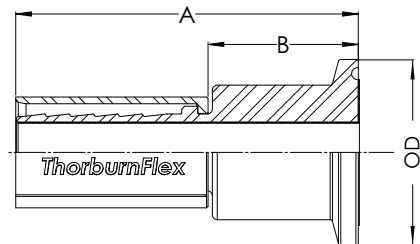

| Part Number | Nominal Hose I.D. | | Nominal Flange Size | | A | | B Cutoff Allowance | | Flange I.D. | | Flange O.D. | |
|------------------|-------------------|----|---------------------|----|------|-----|--------------------|----|-------------|----|-------------|----|
| | Inch | mm | Inch | mm | Inch | mm | Inch | mm | Inch | mm | Inch | mm |
| TS11-08-16TSFAE | 1/2 | 12 | 1 | 25 | 3.22 | 82 | 1.72 | 44 | 0.87 | 22 | 1.34 | 50 |
| TS11-12-16TSFAE | 3/4 | 20 | 1 | 25 | 3.41 | 87 | 1.72 | 44 | 0.87 | 22 | 1.34 | 50 |
| TS11-16-16TSFAE | 1 | 25 | 1 | 25 | 3.92 | 100 | 1.72 | 44 | 0.87 | 22 | 1.34 | 50 |
| TS11-08-16TSFB E | 1/2 | 12 | 1 | 25 | 3.22 | 82 | 1.72 | 44 | 0.87 | 22 | 1.98 | 50 |
| TS11-12-16TSFB E | 3/4 | 20 | 1 | 25 | 3.41 | 87 | 1.72 | 44 | 0.87 | 22 | 1.98 | 50 |
| TS11-16-16TSFB E | 1 | 25 | 1 | 25 | 3.92 | 100 | 1.72 | 44 | 0.87 | 22 | 1.98 | 50 |
| TS11-08-24TSFB E | 1/2 | 12 | 1 1/2 | 40 | 3.34 | 85 | 1.97 | 50 | 1.37 | 35 | 1.98 | 50 |
| TS11-12-24TSFB E | 3/4 | 20 | 1 1/2 | 40 | 3.66 | 93 | 1.97 | 50 | 1.37 | 35 | 1.98 | 50 |
| TS11-16-24TSFB E | 1 | 25 | 1 1/2 | 40 | 4.17 | 106 | 1.97 | 50 | 1.37 | 35 | 1.98 | 50 |

Materials: 316 Stainless Steel insert encapsulated with PTFE. Material ordering codes are found on Page 76

TS11/TS12 Series “TS” PTFE Hose Couplings

Female “Type C” Cam & Groove Couplings



| Part Number | Nominal Hose I.D. | | Fitting Size | | A | | B Cutoff Allowance | | C O.D. | | D Ext. Cam Arms | |
|-------------|-------------------|----|--------------|----|------|-----|--------------------|----|--------|----|-----------------|-----|
| | Inch | mm | Inch | mm | Inch | mm | Inch | mm | Inch | mm | Inch | mm |
| TS11-08-08C | 1/2 | 12 | 1/2 | 12 | 3.9 | 99 | 2.4 | 61 | 2.1 | 53 | 4.5 | 114 |
| TS11-12-12C | 3/4 | 20 | 3/4 | 20 | 4.1 | 104 | 2.4 | 61 | 2.1 | 53 | 4.5 | 114 |
| TS11-16-16C | 1 | 25 | 1 | 25 | 5.0 | 127 | 2.8 | 71 | 2.4 | 61 | 5.1 | 130 |
| TS11-20-20C | 1 1/4 | 30 | 1 1/4 | 30 | 5.9 | 150 | 3.1 | 79 | 3.3 | 84 | 6.9 | 175 |

Materials: 316 Stainless Steel. Material ordering codes are found on Page 76

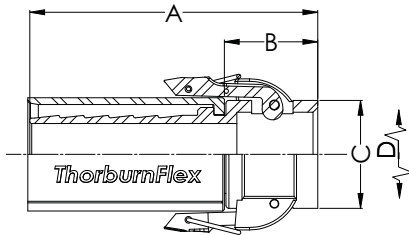

Male “Type E” Cam & Groove Couplings



| Part Number | Nominal Hose I.D. | | Fitting Size | | A | | B Cutoff Allowance | | C O.D. | |
|-------------|-------------------|----|--------------|----|------|-----|--------------------|----|--------|----|
| | Inch | mm | Inch | mm | Inch | mm | Inch | mm | Inch | mm |
| TS11-08-08E | 1/2 | 12 | 1/2 | 12 | 4.1 | 104 | 2.6 | 66 | 1.3 | 33 |
| TS11-12-12E | 3/4 | 20 | 3/4 | 20 | 4.3 | 109 | 2.6 | 66 | 1.3 | 33 |
| TS11-16-16E | 1 | 25 | 1 | 25 | 5.0 | 127 | 3.0 | 76 | 1.6 | 41 |
| TS11-20-20E | 1 1/4 | 30 | 1 1/4 | 30 | 6.3 | 160 | 3.5 | 89 | 2.0 | 50 |

Materials: 316 Stainless Steel. Material ordering codes are found on Page 76

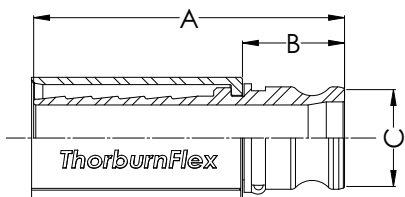

TS11/TS12 Series “TS” PTFE Hose Couplings

Female Encapsulated “Type C” Cam & Groove Couplings



| Part Number | Nominal Hose I.D. | | Fitting Size | | Encap. I.D. | | A | | B Cutoff Allowance | | C O.D. | | D Ext. Cam Arms | |
|---------------|-------------------|----|--------------|----|-------------|----|------|-----|--------------------|----|--------|----|-----------------|-----|
| | Inch | mm | Inch | mm | Inch | mm | Inch | mm | Inch | mm | Inch | mm | Inch | mm |
| TS11-12-12CEC | 1/2 | 12 | 1/2 | 12 | 0.5 | 12 | 4.1 | 104 | 2.4 | 61 | 2.1 | 53 | 4.5 | 114 |
| TS11-16-16CEC | 3/4 | 20 | 3/4 | 20 | 0.6 | 15 | 5.0 | 127 | 2.8 | 71 | 2.4 | 61 | 5.1 | 130 |

Materials: 316 Stainless Steel insert encapsulated with PTFE. Material ordering codes are found on Page 76

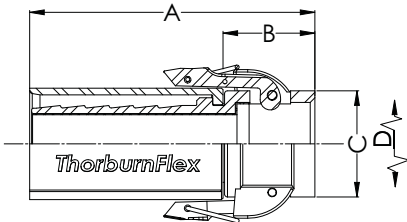

Male Encapsulated “Type E” Cam & Groove Couplings



| Part Number | Nominal Hose I.D. | | Fitting Size | | Encap. I.D. | | A | | B Cutoff Allowance | | C O.D. | |
|-------------|-------------------|----|--------------|----|-------------|----|------|-----|--------------------|----|--------|----|
| | Inch | mm | Inch | mm | Inch | mm | Inch | mm | Inch | mm | Inch | mm |
| TS11-12-12E | 3/4 | 20 | 3/4 | 20 | 0.5 | 12 | 4.3 | 109 | 2.6 | 66 | 1.3 | 33 |
| TS11-16-16E | 1 | 25 | 1 | 25 | 0.6 | 15 | 5.0 | 127 | 3.5 | 89 | 1.6 | 41 |

Materials: 316 Stainless Steel insert encapsulated with PTFE. Material ordering codes are found on Page 76

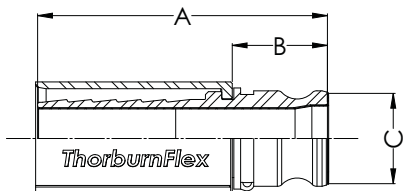

TS11/TS12 Series “TS” PTFE Hose Couplings

Male BSPP Rigid

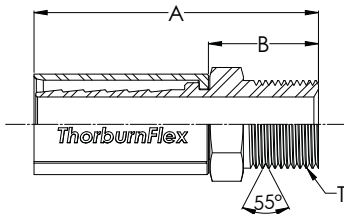

| Part Number | Nominal Hose I.D. | | Fitting Size | | Thread Size | A | | B Cutoff Allowance | | H Hex |
|----------------|-------------------|----|--------------|----|-------------|------|-----|--------------------|----|-------|
| | Inch | mm | Inch | mm | | Inch | mm | Inch | mm | |
| TS11-04-04BSPP | 1/4 | 06 | 1/4 | 06 | 1/4-18 | 2.20 | 56 | 1.17 | 30 | 5/8 |
| TS11-06-06BSPP | 3/8 | 10 | 3/8 | 10 | 3/8-18 | 2.26 | 57 | 1.18 | 30 | 3/4 |
| TS11-08-08BSPP | 1/2 | 12 | 1/2 | 12 | 1/2-16 | 2.76 | 70 | 1.32 | 34 | 7/8 |
| TS11-10-10BSPP | 5/8 | 16 | 5/8 | 16 | 5/8-14 | 2.82 | 72 | 1.38 | 35 | 1 |
| TS11-12-12BSPP | 3/4 | 20 | 3/4 | 20 | 3/4-12 | 3.21 | 82 | 1.50 | 38 | 1 1/8 |
| TS11-16-16BSPP | 1 | 25 | 1 | 25 | 1-12 | 3.60 | 91 | 1.89 | 48 | 1 1/2 |
| TS11-20-20BSPP | 1 1/4 | 30 | 1 1/4 | 30 | 1 1/4-12 | 4.13 | 105 | 1.83 | 46 | 1 3/4 |

Materials: 316 Stainless Steel. Material ordering codes are found on Page 76

Male Tapered BSPT

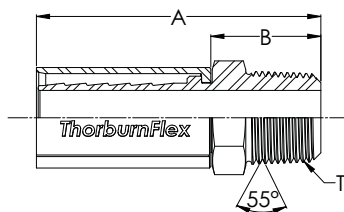

| Part Number | Nominal Hose I.D. | | Fitting Size | | Thread Size | A | | B Cutoff Allowance | | H Hex |
|-----------------|-------------------|----|--------------|----|-------------|------|----|--------------------|----|-------|
| | Inch | mm | Inch | mm | | Inch | mm | Inch | mm | |
| TS11-04-04MBSPT | 1/4 | 06 | 1/4 | 06 | 1/4-19 | 2.20 | 56 | 1.17 | 30 | 5/8 |
| TS11-06-06MBSPT | 3/8 | 10 | 3/8 | 10 | 3/8-19 | 2.26 | 57 | 1.18 | 30 | 3/4 |
| TS11-08-08MBSPT | 1/2 | 12 | 1/2 | 12 | 1/2-14 | 2.76 | 70 | 1.32 | 34 | 7/8 |
| TS11-12-12MBSPT | 3/4 | 20 | 3/4 | 20 | 3/4-14 | 3.21 | 82 | 1.50 | 38 | 1 1/8 |
| TS11-16-16MBSPT | 1 | 25 | 1 | 25 | 1-12 | 3.60 | 91 | 1.89 | 48 | 1 1/2 |

Materials: 316 Stainless Steel. Material ordering codes are found on Page 76

TS11/TS12 Series “TS” PTFE Hose Couplings

Female JIS (Japanese Industrial Standard) Swivel

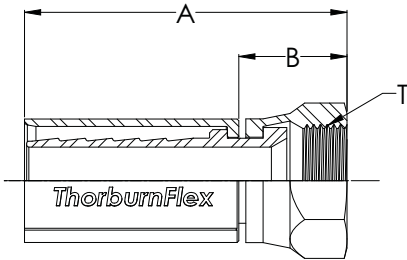

| Part Number | Nominal Hose I.D. | | Fitting Size | | Thread Size | A | | B Cutoff Allowance | | H Hex |
|-----------------|-------------------|----|--------------|----|-------------|------|----|--------------------|----|--------|
| | Inch | mm | Inch | mm | | Inch | mm | Inch | mm | Inch |
| TS11-04-04FJISX | 1/4 | 06 | 1/4 | 06 | 1/4-19 | 2.00 | 51 | 0.91 | 23 | 5/8 |
| TS11-06-06FJISX | 3/8 | 10 | 3/8 | 10 | 3/8-19 | 2.00 | 51 | 0.99 | 25 | 3/4 |
| TS11-08-08FJISX | 1/2 | 12 | 1/2 | 12 | 1/2-14 | 2.57 | 65 | 1.13 | 29 | 7/8 |
| TS11-10-10FJISX | 5/8 | 16 | 5/8 | 16 | 5/8-14 | 2.60 | 66 | 1.16 | 29 | 1 1/16 |
| TS11-12-12FJISX | 3/4 | 20 | 3/4 | 20 | 3/4-14 | 3.00 | 76 | 1.29 | 33 | 1 1/8 |
| TS11-16-16FJISX | 1 | 25 | 1 | 25 | 1-11 | 3.21 | 82 | 1.50 | 38 | 1 1/4 |

Materials: 316 Stainless Steel. Material ordering codes are found on Page 76

Male Light Duty O-Ring Boss

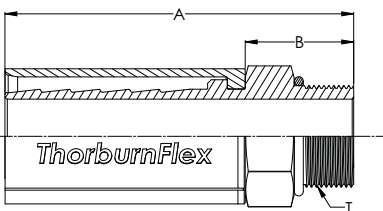

| Part Number | Nominal Hose I.D. | | Fitting Size | | Thread Size | A | | B Cutoff Allowance | | H Hex |
|----------------|-------------------|----|--------------|----|-------------|------|----|--------------------|----|-------|
| | Inch | mm | Inch | mm | | Inch | mm | Inch | mm | Inch |
| TS11-04-04MBLD | 1/4 | 6 | 1/4 | 6 | 7/16-20 | 2.16 | 55 | 1.14 | 28 | 1/2 |
| TS11-06-06MBLD | 3/8 | 10 | 3/8 | 10 | 9/16-18 | 2.16 | 55 | 1.15 | 29 | 11/16 |
| TS11-08-08MBLD | 1/2 | 12 | 1/2 | 12 | 3/4-16 | 2.80 | 71 | 1.36 | 35 | 7/8 |
| TS11-10-10MBLD | 5/8 | 16 | 5/8 | 16 | 7/8-14 | 3.09 | 78 | 1.65 | 42 | 7/8 |
| TS11-12-12MBLD | 3/4 | 20 | 3/4 | 20 | 1 1/16-12 | 3.41 | 87 | 1.70 | 43 | 1 1/8 |
| TS11-16-16MBLD | 1 | 25 | 1 | 25 | 1 5/16-12 | 3.66 | 93 | 1.95 | 49 | 1 3/8 |

Materials: 316 Stainless Steel, Brass Insert with Steel or Brass Ferrule.
Material ordering codes are found on Page 76

TS11/TS12 Series “TS” PTFE Hose Couplings

DIN Male Light Series

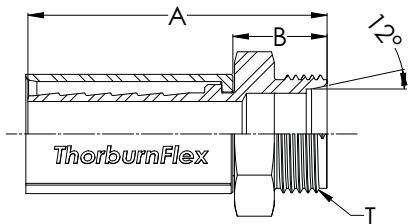

| Part Number | Nominal Hose I.D. | | Fitting Size mm | Thread Size | A | | B Cutoff Allowance | | H Hex mm |
|---------------|-------------------|----|--------------------|-------------|------|-----|-----------------------|----|----------------|
| | Inch | mm | | | Inch | mm | Inch | mm | |
| TS11-04-14MDL | 1/4 | 06 | 16 | M14 - 1.5 | 2.00 | 51 | 0.91 | 23 | 8 |
| TS11-04-15MDL | 1/4 | 06 | 16 | M16 - 1.5 | 2.06 | 52 | 0.98 | 25 | 10 |
| TS11-06-16MDL | 3/8 | 10 | 16 | M16 - 1.5 | 2.06 | 52 | 0.98 | 25 | 10 |
| TS11-06-18MDL | 3/8 | 10 | 18 | M18 - 1.5 | 2.10 | 53 | 0.98 | 25 | 12 |
| TS11-08-22MDL | 1/2 | 12 | 22 | M22 - 1.5 | 2.57 | 65 | 1.13 | 29 | 15 |
| TS11-10-26MDL | 5/8 | 16 | 26 | M26 - 1.5 | 2.60 | 66 | 1.16 | 29 | 18 |
| TS11-12-30MDL | 3/4 | 20 | 30 | M30 - 2.0 | 3.00 | 76 | 1.29 | 33 | 22 |
| TS11-16-36MDL | 1 | 25 | 36 | M36 - 2.0 | 3.21 | 82 | 1.50 | 38 | 28 |
| TS11-20-45MDL | 1 1/4 | 30 | 45 | M45 - 2.0 | 4.06 | 103 | 1.77 | 45 | 35 |

Materials: 316 Stainless Steel. Material ordering codes are found on Page 76

DIN Female Swivel Straight Light Universal Series 24°/60° Inverted Cone

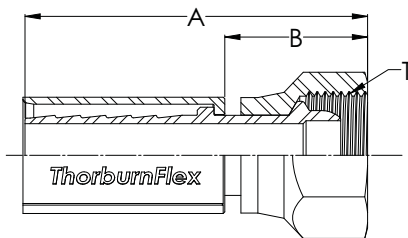

| Part Number | Nominal Hose I.D. | | Fitting Size mm | Thread Size | A | | B Cutoff Allowance | | H Hex mm |
|----------------|-------------------|----|--------------------|-------------|------|-----|-----------------------|----|----------------|
| | Inch | mm | | | Inch | mm | Inch | mm | |
| TS11-04-12FDLX | 1/4 | 06 | 12 | M12 - 1.5 | 2.20 | 56 | 1.11 | 28 | 14 |
| TS11-04-14FDLX | 1/4 | 06 | 14 | M14 - 1.5 | 2.21 | 56 | 1.12 | 28 | 14 |
| TS11-04-16FDLX | 1/4 | 06 | 16 | M16 - 1.5 | 2.33 | 59 | 1.24 | 31 | 19 |
| TS11-06-16FDLX | 3/8 | 10 | 16 | M16 - 1.5 | 2.40 | 61 | 1.24 | 31 | 19 |
| TS11-06-18FDLX | 3/8 | 10 | 18 | M18 - 1.5 | 2.42 | 61 | 1.36 | 35 | 22 |
| TS11-08-20FDLX | 1/2 | 12 | 20 | M20 - 1.5 | 3.04 | 77 | 1.63 | 41 | 27 |
| TS11-08-22FDLX | 1/2 | 12 | 22 | M22 - 1.5 | 3.12 | 79 | 1.70 | 43 | 27 |
| TS11-10-26FDLX | 5/8 | 16 | 26 | M26 - 1.5 | 3.14 | 80 | 1.71 | 43 | 32 |
| TS11-12-30FDLX | 3/4 | 20 | 30 | M30 - 1.5 | 3.24 | 82 | 1.53 | 39 | 36 |
| TS11-16-36FDLX | 1 | 25 | 36 | M36 - 2.0 | 3.66 | 93 | 1.95 | 50 | 46 |
| TS11-20-45FDLX | 1 1/4 | 30 | 45 | M45 - 2.0 | 4.76 | 121 | 2.46 | 62 | 55 |

Also available in 45° & 90° bent stems

Materials: 316 Stainless Steel. Material ordering codes are found on Page 76

TS11/TS12 Series “TS” PTFE Hose Couplings

DIN Male Heavy Series

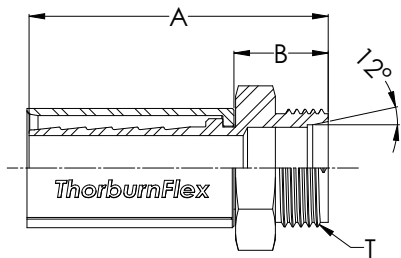

| Part Number | Nominal Hose I.D. | | Fitting Size mm | Thread Size | A | | B Cutoff Allowance | | H Hex mm |
|---------------|-------------------|----|--------------------|-------------|------|----|-----------------------|----|----------------|
| | Inch | mm | | | Inch | mm | Inch | mm | |
| TS11-04-16MDH | 1/4 | 06 | 16 | M16 - 1.5 | 2.09 | 53 | 1.06 | 27 | 17 |
| TS11-04-18MDH | 1/4 | 06 | 18 | M18 - 1.5 | 2.09 | 53 | 1.04 | 26 | 19 |
| TS11-06-18MDH | 3/8 | 10 | 18 | M18 - 1.5 | 2.17 | 55 | 1.07 | 27 | 19 |
| TS11-06-20MDH | 3/8 | 10 | 20 | M20 - 1.5 | 2.26 | 57 | 1.17 | 30 | 24 |
| TS11-08-20MDH | 1/2 | 12 | 20 | M20 - 1.5 | 2.42 | 61 | 1.20 | 30 | 24 |
| TS11-10-24MDH | 1/2 | 12 | 24 | M24 - 1.5 | 2.72 | 69 | 1.24 | 31 | 27 |
| TS11-12-30MDH | 3/4 | 20 | 30 | M30 - 2.0 | 2.85 | 72 | 1.33 | 34 | 32 |
| TS11-16-36MDH | 3/4 | 20 | 36 | M36 - 2.0 | 3.62 | 92 | 1.61 | 41 | 41 |
| TS11-20-42MDH | 1 | 25 | 42 | M42 - 2.0 | 3.48 | 88 | 1.64 | 42 | 46 |
| TS11-20-52MDH | 1 1/4 | 30 | 52 | M52 - 2.0 | 3.72 | 94 | 1.93 | 49 | 55 |

Materials: 316 Stainless Steel. Material ordering codes are found on Page 76

DIN Female Swivel Straight Heavy Series 24° Inverted Cone

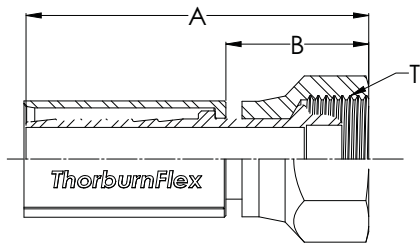

| Part Number | Nominal Hose I.D. | | Fitting Size mm | Thread Size | A | | B Cutoff Allowance | | H Hex mm |
|----------------|-------------------|----|--------------------|-------------|------|-----|-----------------------|----|----------------|
| | Inch | mm | | | Inch | mm | Inch | mm | |
| TS11-04-16FDHX | 1/4 | 06 | 16 | M16 - 1.5 | 2.34 | 59 | 1.25 | 32 | 19 |
| TS11-04-18FDHX | 1/4 | 06 | 18 | M18 - 1.5 | 2.42 | 61 | 1.34 | 34 | 22 |
| TS11-06-20FDHX | 3/8 | 10 | 20 | M20 - 1.5 | 2.42 | 61 | 1.35 | 34 | 24 |
| TS11-06-22FDHX | 3/8 | 10 | 22 | M22 - 1.5 | 2.52 | 64 | 1.49 | 38 | 27 |
| TS11-08-22FDHX | 1/2 | 12 | 22 | M22 - 1.5 | 3.04 | 77 | 1.63 | 41 | 27 |
| TS11-08-24FDHX | 1/2 | 12 | 24 | M24 - 1.5 | 3.10 | 79 | 1.65 | 42 | 30 |
| TS11-10-30FDHX | 5/8 | 16 | 30 | M30 - 2.0 | 3.24 | 82 | 1.84 | 47 | 36 |
| TS11-10-36FDHX | 5/8 | 16 | 36 | M36 - 2.0 | 3.52 | 89 | 2.08 | 53 | 46 |
| TS11-12-30FDHX | 3/4 | 20 | 30 | M30 - 2.0 | 3.55 | 90 | 2.10 | 53 | 36 |
| TS11-12-36FDHX | 3/4 | 20 | 36 | M36 - 2.0 | 3.79 | 96 | 2.12 | 54 | 46 |
| TS11-16-42FDHX | 1 | 25 | 42 | M42 - 2.0 | 4.19 | 106 | 2.48 | 63 | 51 |

Also available in 45° & 90° bent stems

Materials: 316 Stainless Steel. Material ordering codes are found on Page 76

TSX16 PTFE Hose Assemblies



| TSX16 Hose Assembly |

APPLICATIONS:

- Transfer of industrial gases (for high effusion applications consult Thorburn)
- Reaction Injection Molding (R.I.M)
- Hydraulic service and phosphate ester fluids
- Compressed natural gas
- Transfer of automotive sealants

Thorburn's **TSX16** high pressure Teflon hose is nearly 50% lighter than any other high pressure spiral wrapped PTFE hose without reduction in strength or reliability. TSX16 has an antistatic conductive carbon black added to the PTFE to dissipate an electrostatic charge in fuel, steam, or high flow-rate applications.

HOSE CONSTRUCTION:

INNER CORE: Smooth extruded unpigmented PTFE with added zero static conductive carbon black. Compliant with ISO 12086 Part 1.

REINFORCEMENT: A580 type 304 (EN1.4301) high tensile single or multiple stainless steel spiral braid that is pre-tensioned to yield a tight bend radius.

TEMPERATURE RANGE: -54°C to 204°C (-65°F to 400°F).

Temperature adjusted temperature ratings, consult Thorburn.

STANDARDS:

Meets requirements of SAE 100R8 & 100R9.

AEROSPACE STANDARDS (on request):

SAE AS1339, TSO C75 Type IIIB-S/P – F/TSO075-11138/D, AS1055 Type IIa & IIb, Class A & B, Integral and Slip-on Thorburn FJ72 Fry-Sil Jacket.

| Part Number | Nominal Size | | Nominal I.D. | | Nominal O.D. | | Operating Pressure | | Room Temp. Min. Burst | | Max. Continuous Length | | Min. Bend Radius | | Hose Weight | |
|-------------|--------------|-------|--------------|------|--------------|------|--------------------|------|-----------------------|-------|------------------------|----|------------------|------|-------------|-------|
| | mm | in | mm | in | mm | in | bar | psi | bar | psi | m | ft | mm | in | kg/m | lb/ft |
| TSX16-4 | 8 | 1/4 | 5.59 | 0.22 | 9.91 | 0.39 | 275.8 | 4000 | 1103.2 | 16000 | 15.2 | 50 | 38.1 | 1.5 | 0.01 | 0.10 |
| TSX16-6 | 10 | 3/8 | 7.87 | 0.31 | 12.4 | 0.49 | 275.8 | 4000 | 1103.2 | 16000 | 15.2 | 50 | 63.5 | 2.5 | 0.24 | 0.16 |
| TSX16-8 | 15 | 1/2 | 10.2 | 0.40 | 15.6 | 0.62 | 275.8 | 4000 | 1103.2 | 16000 | 11.6 | 38 | 73.7 | 2.9 | 0.34 | 0.23 |
| TSX16-10 | 18 | 5/8 | 12.7 | 0.50 | 18.5 | 0.73 | 275.8 | 4000 | 1103.2 | 16000 | 11.6 | 38 | 83.8 | 3.3 | 0.49 | 0.33 |
| TSX16-12 | 20 | 3/4 | 15.8 | 0.62 | 25.2 | 0.99 | 275.8 | 4000 | 1103.2 | 16000 | 11.6 | 38 | 99.1 | 3.9 | 0.98 | 0.66 |
| TSX16-16 | 25 | 1 | 22.1 | 0.87 | 32.3 | 1.27 | 275.8 | 4000 | 1103.2 | 16000 | 11.6 | 38 | 127.0 | 5.0 | 1.52 | 1.02 |
| TSX16-20 | 32 | 1 1/4 | 28.4 | 1.12 | 42.2 | 1.66 | 275.8 | 4000 | 1103.2 | 16000 | 6.10 | 20 | 304.8 | 12.0 | 2.75 | 1.85 |
| TSX16-24 | 40 | 1 1/2 | 35.1 | 1.38 | 48.3 | 1.90 | 206.8 | 3000 | 827.4 | 12000 | 6.10 | 20 | 355.6 | 14.0 | 2.84 | 1.91 |

TSX16 PTFE Hose Permanent Fittings

Female JIC 37° Swivel

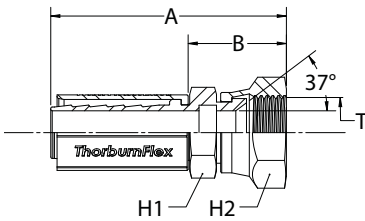

| Part Number | Nominal Hose I.D. | | Fitting Size | | Thread Size | A | | B Cutoff Allowance | | H Hex |
|----------------|-------------------|----|--------------|----|-------------|------|-----|--------------------|----|-------|
| | Inch | mm | Inch | mm | | Inch | mm | Inch | mm | |
| TSX16-04-04FJX | 1/4 | 6 | 1/4 | 6 | 7/16-20 | 2.24 | 57 | 1.22 | 31 | 0.69 |
| TSX16-06-06FJX | 3/8 | 10 | 3/8 | 10 | 9/16-18 | 2.32 | 59 | 1.22 | 31 | 0.75 |
| TSX16-08-08FJX | 1/2 | 12 | 1/2 | 12 | 3/4-16 | 2.88 | 73 | 1.32 | 34 | 0.88 |
| TSX16-10-10FJX | 5/8 | 16 | 5/8 | 16 | 7/8-14 | 3.47 | 88 | 1.60 | 41 | 1.00 |
| TSX16-12-12FJX | 3/4 | 20 | 3/4 | 20 | 1 1/16-12 | 3.77 | 96 | 1.68 | 43 | 1.25 |
| TSX16-16-16FJX | 1 | 25 | 1 | 25 | 1 5/16-12 | 4.13 | 105 | 1.92 | 49 | 1.50 |
| TSX16-20-20FJX | 1 1/4 | 30 | 1 1/4 | 30 | 1 5/8-12 | 5.29 | 134 | 2.28 | 58 | 1.81 |
| TSX16-24-24FJX | 1 1/2 | 40 | 1 1/2 | 40 | 1 7/8-12 | 5.42 | 138 | 2.46 | 62 | 2.12 |

Materials: 316 Stainless Steel, Carbon Steel. Material ordering codes are found on Page 76

Female JIC Swivel 45° Elbow

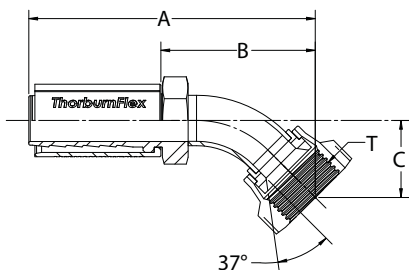

| Part Number | Nominal Hose I.D. | | Fitting Size | | Thread Size | A | | B Cutoff Allowance | | H Hex |
|------------------|-------------------|----|--------------|----|-------------|------|-----|--------------------|----|-------|
| | Inch | mm | Inch | mm | | Inch | mm | Inch | mm | |
| TSX16-04-04FJX45 | 1/4 | 6 | 1/4 | 6 | 7/16-20 | 3.36 | 85 | 2.34 | 59 | 0.41 |
| TSX16-06-06FJX45 | 3/8 | 10 | 3/8 | 10 | 9/16-18 | 3.36 | 85 | 2.34 | 59 | 0.56 |
| TSX16-08-08FJX45 | 1/2 | 12 | 1/2 | 12 | 3/4-16 | 3.78 | 96 | 2.47 | 63 | 0.78 |
| TSX16-12-12FJX45 | 3/4 | 20 | 3/4 | 20 | 1 1/16-12 | 5.30 | 135 | 3.29 | 84 | 1.06 |

Materials: 316 Stainless Steel, Carbon Steel. Material ordering codes are found on Page 76

TSX16 PTFE Hose Permanent Fittings

Female JIC Swivel 90° Elbow

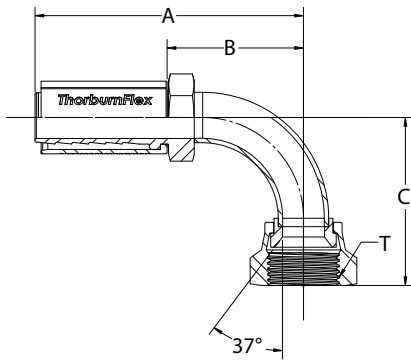

| Part Number | Nominal Hose I.D. | | Fitting Size | | Thread Size | A | | B Cutoff Allowance | | H Hex |
|------------------|-------------------|----|--------------|----|-------------|------|-----|--------------------|----|-------|
| | Inch | mm | Inch | mm | | Inch | mm | Inch | mm | |
| TSX16-04-04FJX90 | 1/4 | 6 | 1/4 | 6 | 7/16-20 | 2.68 | 68 | 1.60 | 41 | 0.88 |
| TSX16-06-06FJX90 | 3/8 | 10 | 3/8 | 10 | 7/16-18 | 2.68 | 68 | 1.60 | 41 | 1.09 |
| TSX16-08-08FJX90 | 1/2 | 12 | 1/2 | 12 | 3/4-16 | 3.46 | 88 | 1.88 | 48 | 1.38 |
| TSX16-12-12FJX90 | 3/4 | 20 | 3/4 | 20 | 1 1/16-12 | 4.88 | 124 | 2.81 | 71 | 2.28 |

Materials: 316 Stainless Steel, Carbon Steel. Material ordering codes are found on Page 76

Female "O"Seal™ Swivel Straight

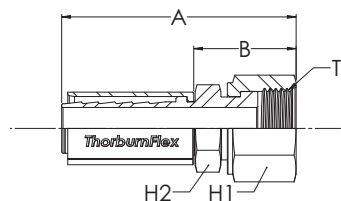

| Part Number | Nominal Hose I.D. | | Fitting Size | | Thread Size | A | | B Cutoff Allowance | | H Hex |
|----------------|-------------------|----|--------------|----|-------------|------|-----|--------------------|----|-------|
| | Inch | mm | Inch | mm | | Inch | mm | Inch | mm | |
| TSX16-04-04FFX | 1/4 | 6 | 1/4 | 6 | 9/16-18 | 2.27 | 58 | 1.22 | 31 | 0.75 |
| TSX16-06-06FFX | 3/8 | 10 | 3/8 | 10 | 11/16-16 | 2.32 | 59 | 1.29 | 33 | 0.82 |
| TSX16-08-08FFX | 1/2 | 12 | 1/2 | 12 | 13/16-16 | 2.88 | 73 | 1.41 | 36 | 0.94 |
| TSX16-10-10FFX | 5/8 | 16 | 5/8 | 16 | 1-14 | 3.40 | 86 | 1.66 | 42 | 1.16 |
| TSX16-12-12FFX | 3/4 | 20 | 3/4 | 20 | 1 3/16-12 | 3.91 | 99 | 1.90 | 48 | 1.37 |
| TSX16-16-16FFX | 1 | 25 | 1 | 25 | 1 7/16-12 | 4.42 | 112 | 2.13 | 54 | 1.63 |
| TSX16-20-20FFX | 1 1/4 | 30 | 1 1/4 | 30 | 1 11/16-12 | 5.17 | 131 | 2.37 | 60 | 1.88 |
| TSX16-24-24FFX | 1 1/2 | 40 | 1 1/2 | 40 | 2-12 | 5.17 | 131 | 2.37 | 60 | 2 |

Materials: 316 Stainless Steel, Carbon Steel. Material ordering codes are found on Page 76

TSX16 PTFE Hose Permanent Fittings

Female “O”Seal™ Swivel 45° Elbow



| Part Number | Nominal Hose I.D. | | Fitting Size | | Thread Size | A | | B Cutoff Allowance | | H Hex |
|------------------|-------------------|----|--------------|----|-------------|------|-----|--------------------|----|-------|
| | Inch | mm | Inch | mm | | Inch | mm | Inch | mm | |
| TSX16-04-04FFX45 | 1/4 | 6 | 1/4 | 6 | 9/16-18 | 2.81 | 71 | 1.79 | 45 | 0.41 |
| TSX16-06-06FFX45 | 3/8 | 10 | 3/8 | 10 | 11/16-16 | 2.81 | 71 | 1.79 | 45 | 0.43 |
| TSX16-08-08FFX45 | 1/2 | 12 | 1/2 | 12 | 13/16-16 | 4.05 | 103 | 2.58 | 66 | 0.59 |
| TSX16-12-12FFX45 | 3/4 | 20 | 3/4 | 20 | 1 3/16-12 | 5.94 | 151 | 2.92 | 74 | 0.83 |

Materials: 316 Stainless Steel, Carbon Steel. Material ordering codes are found on Page 76

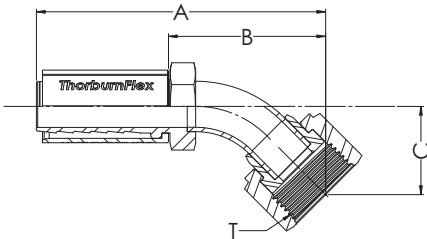

Female “O”Seal™ Swivel 90° Elbow



| Part Number | Nominal Hose I.D. | | Fitting Size | | Thread Size | A | | B Cutoff Allowance | | H Hex |
|------------------|-------------------|----|--------------|----|-------------|------|-----|--------------------|----|-------|
| | Inch | mm | Inch | mm | | Inch | mm | Inch | mm | |
| TSX16-04-04FFX90 | 1/4 | 6 | 1/4 | 6 | 9/16-18 | 2.68 | 68 | 1.60 | 41 | 1.26 |
| TSX16-06-06FFX90 | 3/8 | 10 | 3/8 | 10 | 11/16-16 | 2.68 | 68 | 1.60 | 41 | 1.51 |
| TSX16-08-08FFX90 | 1/2 | 12 | 1/2 | 12 | 13/16-16 | 3.46 | 88 | 1.88 | 48 | 1.62 |
| TSX16-12-12FFX90 | 3/4 | 20 | 3/4 | 20 | 1 3/16-12 | 4.82 | 122 | 2.81 | 71 | 2.20 |

Materials: 316 Stainless Steel, Carbon Steel. Material ordering codes are found on Page 76

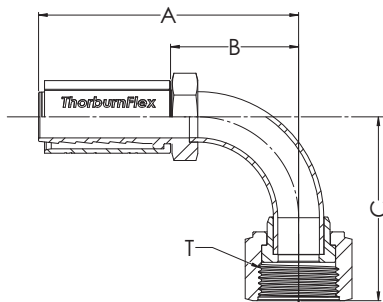

TSX16 PTFE Hose Permanent Fittings

Male Pipe NPT Rigid

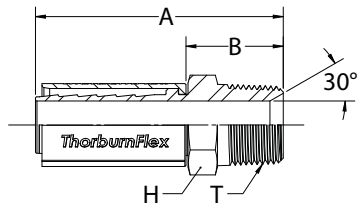

| Part Number | Nominal Hose I.D. | | Fitting Size | | Thread Size | A | | B Cutoff Allowance | | H Hex |
|---------------|-------------------|----|--------------|----|-------------|------|-----|--------------------|----|-------|
| | Inch | mm | Inch | mm | | Inch | mm | Inch | mm | |
| TSX16-04-04MP | 1/4 | 6 | 1/4 | 6 | 7/16-20 | 2.25 | 57 | 1.22 | 31 | 0.63 |
| TSX16-06-06MP | 3/8 | 10 | 3/8 | 10 | 9/16-18 | 2.25 | 57 | 1.22 | 31 | 0.69 |
| TSX16-08-08MP | 1/2 | 12 | 1/2 | 12 | 3/4-16 | 2.90 | 74 | 1.42 | 36 | 0.88 |
| TSX16-12-12MP | 3/4 | 20 | 3/4 | 20 | 1 1/16-12 | 3.55 | 90 | 1.54 | 39 | 1.25 |
| TSX16-16-16MP | 1 | 25 | 1 | 25 | 1 5/16-12 | 4.16 | 106 | 1.82 | 46 | 1.38 |
| TSX16-20-20MP | 1 1/4 | 30 | 1 1/4 | 30 | 1 5/8-12 | 4.98 | 126 | 2.18 | 55 | 1.75 |
| TSX16-24-24MP | 1 1/2 | 40 | 1 1/2 | 40 | 1 7/8-12 | 5.14 | 131 | 2.44 | 62 | 2.00 |

Materials: 316 Stainless Steel, Carbon Steel. Material ordering codes are found on Page 76

Male JIC 37° Rigid

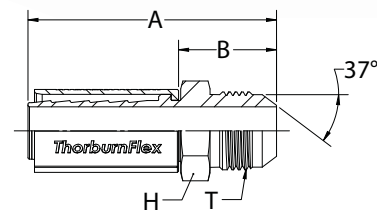

| Part Number | Nominal Hose I.D. | | Fitting Size | | Thread Size | A | | B Cutoff Allowance | | H Hex |
|---------------|-------------------|----|--------------|----|-------------|------|-----|--------------------|----|-------|
| | Inch | mm | Inch | mm | | Inch | mm | Inch | mm | |
| TSX16-04-04MJ | 1/4 | 6 | 1/4 | 6 | 7/16-20 | 2.16 | 55 | 1.14 | 28 | 1/2 |
| TSX16-06-06MJ | 3/8 | 10 | 3/8 | 10 | 9/16-18 | 2.16 | 55 | 1.15 | 29 | 11/16 |
| TSX16-08-08MJ | 1/2 | 12 | 1/2 | 12 | 3/4-16 | 2.80 | 71 | 1.36 | 35 | 7/8 |
| TSX16-12-12MJ | 3/4 | 20 | 3/4 | 20 | 1 1/16-12 | 3.41 | 87 | 1.70 | 43 | 1 1/8 |
| TSX16-16-16MJ | 1 | 25 | 1 | 25 | 1 5/16-12 | 3.66 | 93 | 1.95 | 49 | 1 3/8 |
| TSX16-20-20MJ | 1 1/4 | 30 | 1 1/4 | 30 | 1 5/8-12 | 4.38 | 111 | 2.08 | 53 | 1 3/4 |
| TSX16-24-24MJ | 1 1/2 | 40 | 1 1/2 | 40 | 1 7/8-12 | 4.91 | 125 | 2.27 | 58 | 2 |

Materials: 316 Stainless Steel, Carbon Steel. Material ordering codes are found on Page 76

Male Heavy Duty O-Ring Boss

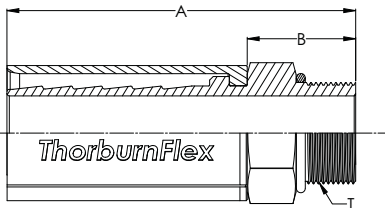

| Part Number | Nominal Hose I.D. | | Fitting Size | | Thread Size | A | | B Cutoff Allowance | | H Hex |
|-----------------|-------------------|----|--------------|----|-------------|------|-----|--------------------|----|-------|
| | Inch | mm | Inch | mm | | Inch | mm | Inch | mm | |
| TSX16-04-04MBHD | 1/4 | 6 | 1/4 | 6 | 7/16-20 | 2.16 | 55 | 1.14 | 28 | 1/2 |
| TSX16-06-06MBHD | 3/8 | 10 | 3/8 | 10 | 9/16-18 | 2.16 | 55 | 1.15 | 29 | 11/16 |
| TSX16-08-08MBHD | 1/2 | 12 | 1/2 | 12 | 3/4-16 | 2.80 | 71 | 1.36 | 35 | 7/8 |
| TSX16-12-12MBHD | 3/4 | 20 | 3/4 | 20 | 1 1/16-12 | 3.41 | 87 | 1.70 | 43 | 1 1/8 |
| TSX16-16-16MBHD | 1 | 25 | 1 | 25 | 1 5/16-12 | 3.66 | 93 | 1.95 | 49 | 1 3/8 |
| TSX16-20-20MBHD | 1 1/4 | 30 | 1 1/4 | 30 | 1 5/8-12 | 3.90 | 99 | 1.98 | 50 | 1 7/8 |
| TSX16-24-24MBHD | 1 1/2 | 40 | 1 1/2 | 40 | 1 7/8-12 | 4.38 | 111 | 2.08 | 53 | 2 |

Materials: 316 Stainless Steel, Carbon Steel. Material ordering codes are found on Page 76

Tube Stub

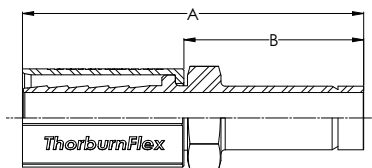

| Part Number | Nominal Hose I.D. | | Fitting Size | | Thread Size | A | | B Cutoff Allowance | | H Hex |
|---------------|-------------------|----|--------------|----|-------------|------|-----|--------------------|----|-------|
| | Inch | mm | Inch | mm | | Inch | mm | Inch | mm | |
| TSX16-04-04TE | 1/4 | 6 | 1/4 | 6 | N/A | 3.26 | 83 | 2.21 | 56 | 0.63 |
| TSX16-06-06TE | 3/8 | 10 | 3/8 | 10 | N/A | 3.26 | 83 | 2.21 | 56 | 0.69 |
| TSX16-08-08TE | 1/2 | 12 | 1/2 | 12 | N/A | 3.79 | 96 | 2.31 | 59 | 0.88 |
| TSX16-12-12TE | 3/4 | 20 | 3/4 | 20 | N/A | 4.90 | 124 | 2.81 | 71 | 1.25 |
| TSX16-16-16TE | 1 | 25 | 1 | 25 | N/A | 5.12 | 130 | 2.91 | 74 | 1.38 |
| TSX16-20-20TE | 1 1/4 | 30 | 1 1/4 | 30 | N/A | 6.28 | 160 | 3.27 | 83 | 1.75 |
| TSX16-24-24TE | 1 1/2 | 40 | 1 1/2 | 40 | N/A | 6.41 | 162 | 3.45 | 88 | 2.00 |

Materials: 316 Stainless Steel, Carbon Steel. Material ordering codes are found on Page 76

TSX17 PTFE Hose Assemblies



| TSX17 Hose Assembly |

APPLICATIONS:

- Ground test and ground support
- High pressure gas and oxygen transfer
- Molten plastics
- Steel mill lance lines
- Pressure wash for industrial and marine applications
- Hydraulic and pneumatic systems

Thorburn's **TSX17** is an extra high pressure hose with smooth conductive inner core of extruded PTFE incorporating zero static construction for a continuous conductive path to the metal end fittings. TSX17 has multiple layers of 304 stainless steel spiral braid for reinforcement.

HOSE CONSTRUCTION:

INNER CORE: Smooth extruded unpigmented PTFE with added zero static conductive carbon black. Compliant with ISO 12086 Part 1.

REINFORCEMENT: A580 type 304 (EN1.4301) high tensile multiple stainless steel spiral braid that is pre-tensioned to yield a tight bend radius.

TEMPERATURE RANGE: -54°C to 204°C (-65°F to 400°F).

Temperature adjusted temperature ratings, consult Thorburn.

STANDARDS:

Meets requirements of SAE 100R8 & 100R9.

AEROSPACE STANDARDS (on request):

SAE AS614, AS1055 Type IIa & IIb, Class A & B Integral and Slip-on Thorburn FJ72 Fry-Sil Jacket.

| Part Number | Nominal Size | | Nominal I.D. | | Nominal O.D. | | Operating Pressure | | Room Temp. Min. Burst | | Max. Continuous Length | | Min. Bend Radius | | Hose Weight | |
|-------------|--------------|-----|--------------|------|--------------|------|--------------------|------|-----------------------|-------|------------------------|----|------------------|-----|-------------|-------|
| | DN | in | mm | in | mm | in | bar | psi | bar | psi | m | ft | mm | in | kg/m | lb/ft |
| TSX17-4 | 8 | 1/4 | 6.10 | 0.24 | 11.4 | 0.45 | 413.7 | 6000 | 1655 | 24000 | 7.6 | 25 | 38.1 | 1.5 | 0.20 | 0.14 |
| TSX17-6 | 10 | 3/8 | 7.62 | 0.30 | 13.7 | 0.54 | 413.7 | 6000 | 1655 | 24000 | 7.6 | 25 | 63.5 | 2.5 | 0.36 | 0.24 |
| TSX17-8 | 15 | 1/2 | 10.7 | 0.42 | 17.5 | 0.69 | 413.7 | 6000 | 1655 | 24000 | 7.6 | 25 | 73.7 | 2.9 | 0.45 | 0.30 |
| TSX17-12 | 20 | 3/4 | 16.0 | 0.63 | 26.4 | 1.04 | 413.7 | 6000 | 1655 | 24000 | 7.6 | 25 | 99.1 | 3.9 | 0.82 | 0.55 |
| TSX17-16 | 25 | 1 | 22.1 | 0.87 | 34.8 | 1.37 | 413.7 | 6000 | 1655 | 24000 | 7.6 | 25 | 127.0 | 5.0 | 1.12 | 0.75 |

TSX17 PTFE Hose Permanent Fittings

Female “O”Seal™ Swivel Straight

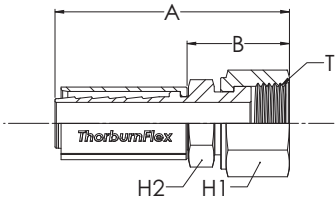

| Part Number | Nominal Hose I.D. | | Fitting Size | | Thread Size | A | | B Cutoff Allowance | | H Hex |
|----------------|-------------------|----|--------------|----|-------------|------|-----|--------------------|----|-------|
| | Inch | mm | Inch | mm | | Inch | mm | Inch | mm | |
| TSX17-04-04FFX | 1/4 | 6 | 1/4 | 6 | 9/16-18 | 2.27 | 58 | 1.22 | 31 | 0.75 |
| TSX17-06-06FFX | 3/8 | 10 | 3/8 | 10 | 11/16-16 | 2.32 | 59 | 1.29 | 33 | 0.82 |
| TSX17-08-08FFX | 1/2 | 12 | 1/2 | 12 | 13/16-16 | 2.88 | 73 | 1.41 | 36 | 0.94 |
| TSX17-12-12FFX | 3/4 | 20 | 3/4 | 20 | 1 3/16-12 | 3.91 | 99 | 1.90 | 48 | 1.37 |
| TSX17-16-16FFX | 1 | 25 | 1 | 25 | 1 7/16-12 | 4.42 | 112 | 2.13 | 54 | 1.63 |

Materials: 316 Stainless Steel, Carbon Steel. Material ordering codes are found on Page 76

Female JIC 37° Swivel

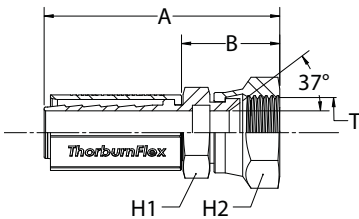

| Part Number | Nominal Hose I.D. | | Fitting Size | | Thread Size | A | | B Cutoff Allowance | | H Hex |
|----------------|-------------------|----|--------------|----|-------------|------|-----|--------------------|----|-------|
| | Inch | mm | Inch | mm | | Inch | mm | Inch | mm | |
| TSX17-04-04FJX | 1/4 | 6 | 1/4 | 6 | 7/16-20 | 2.25 | 57 | 1.22 | 31 | 0.56 |
| TSX17-06-06FJX | 3/8 | 10 | 3/8 | 10 | 9/16-18 | 2.25 | 57 | 1.22 | 31 | 0.75 |
| TSX17-08-08FJX | 1/2 | 12 | 1/2 | 12 | 3/4-16 | 3.00 | 75 | 1.42 | 36 | 0.88 |
| TSX17-12-12FJX | 3/4 | 20 | 3/4 | 20 | 1 1/16-12 | 3.83 | 97 | 1.77 | 45 | 1.25 |
| TSX17-16-16FJX | 1 | 25 | 1 | 25 | 1 5/16-12 | 4.15 | 105 | 1.93 | 49 | 1.50 |

Materials: 316 Stainless Steel, Carbon Steel. Material ordering codes are found on Page 76

TSX18/TSX19 PTFE Hose Assemblies



| TSX18 (top) and TSX19 Hose Assemblies |

APPLICATIONS:

- Electrically charged equipment needing electrical isolation
- Salt water or other corrosive environments
- Any installation where a high pressure hose must be super lightweight
- Ground test and ground support
- Industrial robotics for extreme pressure applications involving bonding materials or other high viscosity fluids
- Industrial gases

Thorburn's **TSX18/TSX19** are lightweight high pressure PTFE hoses which are reinforced with super strong, super lightweight Kevlar aramid fiber. The lightweight design gives at least 50% weight savings over conventional lightweight high pressure PTFE hoses. The non-metallic braid is ideal for applications where electrical continuity between end fittings is not allowed.

HOSE CONSTRUCTION:

TSX18 Inner Core: Smooth extruded unpigmented PTFE

TSX19 Inner Core: Smooth extruded unpigmented PTFE with added zero static conductive carbon black. Compliant with ISO 12086 Part 1.

REINFORCEMENT: Multi-Ply Aramid high tensile fabric & abrasion resistant fabric over braid.

TEMPERATURE RANGE: -54°C to 200°C (-65°F to 400°F)
stainless steel fittings

STANDARDS:

Meets requirements of SAE 100R8 & 100R9.

AEROSPACE STANDARDS (on request):

SAE AS614, AS1055 Type IIa & IIb, Class A & B Integral and Slip-on Thorburn FJ72 Fry-Sil Jacket.

| Part Number | Nominal Size | | Nominal I.D. | | Nominal O.D. | | Operating Pressure | | Room Temp. Min. Burst | | Max. Continuous Length | | Min. Bend Radius | | Hose Weight | |
|----------------|--------------|-----|--------------|------|--------------|------|--------------------|------|-----------------------|-------|------------------------|----|------------------|------|-------------|-------|
| | DN | in | mm | in | mm | in | bar | psi | bar | psi | m | ft | mm | in | kg/m | lb/ft |
| TSX18/TSX19-4 | 8 | 1/4 | 6 | 0.22 | 11 | 0.44 | 207 | 3000 | 827 | 12000 | 15.2 | 50 | 41 | 1.60 | 0.09 | 0.06 |
| TSX18/TSX19-6 | 10 | 3/8 | 8 | 0.31 | 14 | 0.53 | 207 | 3000 | 827 | 12000 | 15.2 | 50 | 66 | 2.60 | 0.12 | 0.08 |
| TSX18/TSX19-8 | 15 | 1/2 | 10 | 0.40 | 17 | 0.66 | 207 | 3000 | 827 | 12000 | 11.6 | 38 | 73 | 2.88 | 0.19 | 0.13 |
| TSX18/TSX19-10 | 18 | 5/8 | 13 | 0.49 | 22 | 0.85 | 207 | 3000 | 827 | 12000 | 11.6 | 38 | 83 | 3.25 | 0.22 | 0.15 |
| TSX18/TSX19-12 | 20 | 3/4 | 15 | 0.60 | 25 | 0.98 | 207 | 3000 | 827 | 12000 | 11.6 | 38 | 102 | 4.00 | 0.34 | 0.23 |

TSX18 PTFE Hose Permanent Fittings

Female Flat Face "O"Seal™ Swivel Straight



| Part Number | Nominal Hose I.D. | | Fitting Size | | Thread Size | A | | B Cutoff Allowance | | H Hex |
|----------------|-------------------|----|--------------|----|-------------|------|----|--------------------|----|-------|
| | Inch | mm | Inch | mm | | Inch | mm | Inch | mm | |
| TSX18-04-04FFX | 1/4 | 6 | 1/4 | 6 | 9/16-18 | 2.27 | 58 | 1.22 | 31 | 0.75 |
| TSX18-06-06FFX | 3/8 | 10 | 3/8 | 10 | 11/16-16 | 2.77 | 70 | 1.46 | 37 | 0.75 |
| TSX18-08-08FFX | 1/2 | 12 | 1/2 | 12 | 13/16-16 | 2.88 | 73 | 1.41 | 36 | 0.94 |
| TSX18-12-12FFX | 3/4 | 20 | 3/4 | 20 | 1 3/16-12 | 3.91 | 99 | 1.90 | 48 | 1.37 |

Materials: 316 Stainless Steel, Carbon Steel. Material ordering codes are found on Page 76

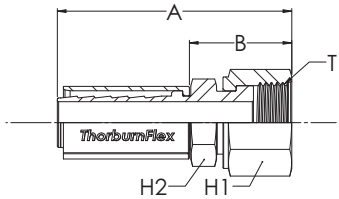

Female JIC 37° Swivel



| Part Number | Nominal Hose I.D. | | Fitting Size | | Thread Size | A | | B Cutoff Allowance | | H Hex |
|----------------|-------------------|----|--------------|----|-------------|------|----|--------------------|----|-------|
| | Inch | mm | Inch | mm | | Inch | mm | Inch | mm | |
| TSX18-04-04FJX | 1/4 | 6 | 1/4 | 6 | 7/16-20 | 2.13 | 54 | 1.04 | 26 | 0.56 |
| TSX18-06-06FJX | 3/8 | 10 | 3/8 | 10 | 9/16-18 | 2.24 | 57 | 1.22 | 31 | 0.75 |
| TSX18-08-08FJX | 1/2 | 12 | 1/2 | 12 | 3/4-16 | 2.76 | 70 | 1.32 | 34 | 0.88 |
| TSX18-12-12FJX | 3/4 | 20 | 3/4 | 20 | 1 1/16-12 | 3.39 | 86 | 1.68 | 43 | 1.25 |

Materials: 316 Stainless Steel, Carbon Steel. Material ordering codes are found on Page 76

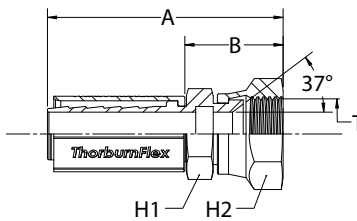

TR40/TR41 PTFE Hose Assemblies



| TR40 (top) and TR41 Hose Assemblies |

APPLICATIONS:

- Pharmaceutical parenterals, lotions, creams, aluminum chloride
- Photo-chemical– Ferricyanide bleach, ferric chloride
- Inks, dyes, glues– hot melt adhesives
- Solvents– from acetone to xylene
- Plating chemicals– sodium cyanide, pickling liquors
- Cleaners– alkali solvents, perchlorohydrate, trichloroethylene
- Black liquor, spill clean-up, spent caustic acid

Thorburn’s TR40/TR41 is specifically designed for full flow applications that require maximum flexibility and minimum weight. The smooth bore PTFE/FEP innercore is ideal to transfer caustic chemicals and high purity media found in food, medical and pharmaceutical industries. The TR40/TR41 is shielded by a tough abrasion resistant EPDM blended cover. The end result provides for greater handling, flexibility and abrasion resistance.

The TR40/TR41 eliminates some of the drawback found in large diameter smooth tube PTFE lined stainless steel braided hose assemblies that tend to kink when bent into a tight radius causing the braid to separate and fray during handling, exposing the hose and the operator to potential dangerous failure.

HOSE CONSTRUCTION:

TR40 INNER CORE: Smooth unpigmented PTFE or FEP firmly bonded to synthetic rubber that will not leach or contaminate product.

TR41 INNER CORE: Smooth extruded PTFE with added antistatic conductive carbon black.

REINFORCEMENT: Multiple layers of high tensile calendared polyester and spring steel helix wire (to prevent kinking) for full vacuum service.

COVER: Smooth compounded EPDM blend to provide outstanding resistance to abrasion, chemicals and weathering.

TEMPERATURE RANGE:

-50°C to 150°C (-58°F to 300°F)

| Part Number | Nominal Size | | Nominal I.D. | | Nominal O.D. | | Operating Pressure | | Room Temp. Min. Burst | | Max. Continuous Length | | Min. Bend Radius | | Hose Weight | |
|-----------------|--------------|-------|--------------|------|--------------|------|--------------------|-----|-----------------------|------|------------------------|-----|------------------|----|-------------|-------|
| | DN | in | mm | in | mm | in | bar | psi | bar | psi | m | ft | mm | in | kg/m | lb/ft |
| TR40-08/TR41-08 | 15 | 1/2 | 13 | 0.50 | 25 | 0.97 | 34.5 | 500 | 137.9 | 2000 | 40 | 130 | 76 | 3 | 0.52 | 0.35 |
| TR40-12/TR41-12 | 20 | 3/4 | 19 | 0.75 | 32 | 1.27 | 34.5 | 500 | 137.9 | 2000 | 40 | 130 | 102 | 4 | 0.92 | 0.62 |
| TR40-16/TR41-16 | 25 | 1 | 25 | 1.00 | 38 | 1.48 | 31.0 | 450 | 124.1 | 1800 | 40 | 130 | 178 | 7 | 1.15 | 0.75 |
| TR40-20/TR41-20 | 32 | 1 1/4 | 32 | 1.25 | 45 | 1.75 | 27.6 | 400 | 110.3 | 1600 | 40 | 130 | 229 | 9 | 1.46 | 0.98 |
| TR40-24/TR41-24 | 40 | 1 1/2 | 38 | 1.50 | 52 | 2.04 | 24.1 | 350 | 96.5 | 1400 | 40 | 130 | 254 | 10 | 1.79 | 1.20 |
| TR40-32/TR41-32 | 50 | 2 | 51 | 2.00 | 65 | 2.54 | 20.7 | 300 | 82.7 | 1200 | 40 | 130 | 356 | 14 | 2.23 | 1.50 |
| TR40-40/TR41-40 | 65 | 2 1/2 | 64 | 2.50 | 77 | 3.04 | 17.2 | 250 | 68.9 | 1000 | 40 | 130 | 457 | 18 | 3.50 | 2.35 |
| TR40-48/TR41-48 | 80 | 3 | 76 | 3.00 | 97 | 3.81 | 13.8 | 200 | 55.2 | 800 | 40 | 130 | 533 | 21 | 3.72 | 2.50 |
| TR40-64/TR41-64 | 100 | 4 | 102 | 4.00 | 127 | 5.00 | 13.8 | 200 | 55.2 | 800 | 40 | 130 | 990 | 39 | 5.21 | 3.50 |
| TR40-96/TR41-96 | 150 | 6 | 152 | 6.00 | 181 | 7.13 | 6.9 | 100 | 48.3 | 700 | 31 | 100 | 1473 | 58 | 7.07 | 4.75 |

TR40/TR41 PTFE Hose Permanent Fittings

Male Pipe NPT Rigid

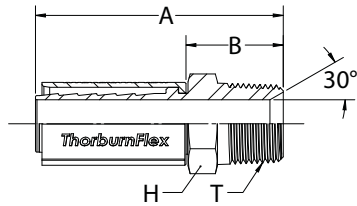

| Part Number | Nominal Hose I.D. | | Fitting Size | | Thread Size | A | | B Cutoff Allowance | | H Hex |
|--------------|-------------------|----|--------------|----|--------------|------|-----|--------------------|----|-------|
| | Inch | mm | Inch | mm | | Inch | mm | Inch | mm | |
| TR40-04-04MP | 1/4 | 6 | 1/4 | 6 | 1/4-18 | 2.13 | 54 | 0.94 | 24 | 0.56 |
| TR40-06-06MP | 3/8 | 10 | 3/8 | 10 | 3/8-18 | 2.25 | 57 | 1.11 | 28 | 0.69 |
| TR40-08-08MP | 1/2 | 12 | 1/2 | 12 | 1/2-14 | 2.91 | 74 | 1.48 | 37 | 0.88 |
| TR40-12-12MP | 3/4 | 20 | 3/4 | 20 | 3/4-14 | 3.22 | 82 | 1.51 | 38 | 1.13 |
| TR40-16-16MP | 1 | 25 | 1 | 25 | 1-11 1/2 | 3.69 | 94 | 1.98 | 50 | 1.38 |
| TR40-20-20MP | 1 1/4 | 30 | 1 1/4 | 30 | 1 1/4-11 1/2 | 4.39 | 112 | 2.09 | 53 | 1.75 |
| TR40-24-24MP | 1 1/2 | 40 | 1 1/2 | 40 | 1 1/2-11 1/2 | 4.82 | 122 | 2.18 | 55 | 2.00 |
| TR40-32-32MP | 2 | 50 | 2 | 50 | 2-11 1/2 | 5.86 | 149 | 2.33 | 59 | 2.50 |
| TR40-48-48MP | 3 | 80 | 3 | 80 | 3-8 | 6.50 | 165 | 3.40 | 86 | 3.50 |

Materials: 316 Stainless Steel. Material ordering codes are found on Page 76

Female JIC 37° Swivel

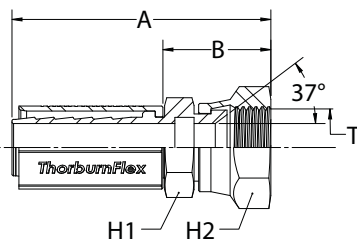

| Part Number | Nominal Hose I.D. | | Fitting Size | | Thread Size | A | | B Cutoff Allowance | | H2 Hex | H1 Hex |
|---------------|-------------------|----|--------------|----|-------------|------|-----|--------------------|----|--------|--------|
| | Inch | mm | Inch | mm | | Inch | mm | Inch | mm | Inch | Inch |
| TR40-04-04FJX | 1/4 | 6 | 1/4 | 6 | 7/16-20 | 2.13 | 54 | 1.04 | 26 | 0.33 | 0.56 |
| TR40-06-06FJX | 3/8 | 10 | 3/8 | 10 | 9/16-18 | 2.25 | 57 | 1.12 | 28 | 0.75 | 0.75 |
| TR40-08-08FJX | 1/2 | 12 | 1/2 | 12 | 3/4-16 | 2.76 | 70 | 1.32 | 34 | 0.69 | 0.88 |
| TR40-12-12FJX | 3/4 | 20 | 3/4 | 20 | 1 1/16-12 | 3.39 | 86 | 1.68 | 43 | 1.00 | 1.25 |
| TR40-16-16FJX | 1 | 25 | 1 | 25 | 1 5/16-12 | 3.63 | 92 | 1.92 | 49 | 1.25 | 1.50 |
| TR40-20-20FJX | 1 1/4 | 30 | 1 1/4 | 30 | 1 5/8-12 | 4.58 | 116 | 2.28 | 58 | 2.00 | 2.00 |
| TR40-24-24FJX | 1 1/2 | 40 | 1 1/2 | 40 | 1 7/8-12 | 5.10 | 130 | 2.46 | 63 | 2.25 | 2.25 |
| TR40-32-32FJX | 2 | 50 | 2 | 50 | 2 1/2-12 | 6.45 | 164 | 2.92 | 74 | 2.50 | 2.88 |

Materials: 316 Stainless Steel. Material ordering codes are found on Page 76

TR40/TR41 PTFE Hose Permanent Fittings

Butt Weld Tube

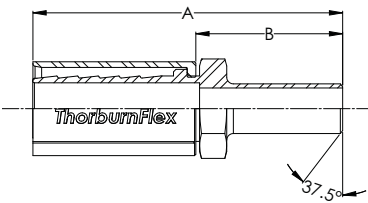

| Part Number | Nominal Hose I.D. | | Tube O.D. | | A | | B Cutoff Allowance | |
|---------------|-------------------|-----|-----------|-----|------|-----|--------------------|-----|
| | Inch | mm | Inch | mm | Inch | mm | Inch | mm |
| TR40-08-08BWT | 1/2 | 12 | 1/2 | 12 | 3.75 | 95 | 1.50 | 38 |
| TR40-12-12BWT | 3/4 | 20 | 3/4 | 20 | 4.00 | 100 | 1.70 | 43 |
| TR40-16-16BWT | 1 | 25 | 1 | 25 | 4.25 | 108 | 1.70 | 43 |
| TR40-24-24BWT | 1 1/2 | 40 | 1 1/2 | 40 | 4.50 | 114 | 2.70 | 69 |
| TR40-32-32BWT | 2 | 50 | 2 | 50 | 5.00 | 127 | 3.50 | 89 |
| TR40-48-48BWT | 3 | 75 | 3 | 75 | 5.75 | 146 | 3.75 | 95 |
| TR40-64-64BWT | 4 | 100 | 4 | 100 | 6.00 | 152 | 4.00 | 100 |

Materials: 316 Stainless Steel. Material ordering codes are found on Page 76

Butt Weld Pipe

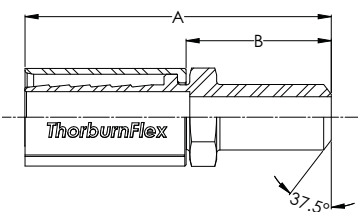

| Part Number | Nominal Hose I.D. | | Pipe O.D. | | A | | B Cutoff Allowance | |
|---------------|-------------------|-----|-----------|-----|------|-----|--------------------|-----|
| | Inch | mm | Inch | mm | Inch | mm | Inch | mm |
| TR40-08-08BWP | 1/2 | 12 | 0.9 | 23 | 3.75 | 95 | 1.50 | 38 |
| TR40-12-12BWP | 3/4 | 20 | 1.1 | 28 | 4.00 | 100 | 1.70 | 43 |
| TR40-16-16BWP | 1 | 25 | 1.3 | 33 | 4.25 | 108 | 1.70 | 43 |
| TR40-24-24BWP | 1 1/2 | 40 | 1.9 | 48 | 4.50 | 114 | 2.70 | 69 |
| TR40-32-32BWP | 2 | 50 | 2.4 | 61 | 5.00 | 127 | 3.50 | 89 |
| TR40-48-48BWP | 3 | 75 | 3.5 | 89 | 5.75 | 146 | 3.75 | 95 |
| TR40-64-64BWP | 4 | 100 | 4.5 | 114 | 6.00 | 152 | 4.00 | 100 |

Materials: 316 Stainless Steel. Material ordering codes are found on Page 76

TR40/TR41 PTFE Hose Permanent Fittings

Tube Stub

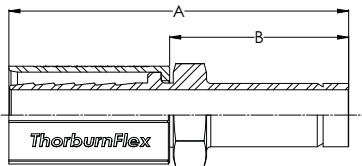

| Part Number | Nominal Hose I.D. | | Tube O.D. | | A | | B Cutoff Allowance | |
|-------------|-------------------|----|-----------|----|------|-----|--------------------|----|
| | Inch | mm | Inch | mm | Inch | mm | Inch | mm |
| TR40-04-04T | 1/4 | 6 | 1/4 | 6 | 1.96 | 49 | 0.80 | 20 |
| TR40-06-06T | 3/8 | 10 | 3/8 | 10 | 2.42 | 61 | 1.22 | 31 |
| TR40-08-08T | 1/2 | 12 | 1/2 | 12 | 2.91 | 74 | 1.44 | 37 |
| TR40-12-12T | 3/4 | 20 | 3/4 | 20 | 3.53 | 90 | 1.84 | 47 |
| TR40-16-16T | 1 | 25 | 1 | 25 | 3.78 | 96 | 1.94 | 49 |
| TR40-24-24T | 1 1/2 | 40 | 1 1/2 | 40 | 5.22 | 133 | 2.53 | 64 |
| TR40-32-32T | 2 | 50 | 2 | 50 | 6.82 | 173 | 3.26 | 83 |

Materials: 316 Stainless Steel. Material ordering codes are found on Page 76

Swagelok™ Compatible Tube Fitting With Nut & Ferrule

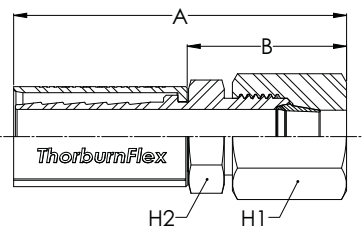

| Part Number | Nominal Hose I.D. | | Tube O.D. | | A | | B Cutoff Allowance | |
|--------------|-------------------|----|-----------|----|------|-----|--------------------|----|
| | Inch | mm | Inch | mm | Inch | mm | Inch | mm |
| TR40-04-04TC | 1/4 | 6 | 1/4 | 6 | 2.02 | 51 | 0.82 | 21 |
| TR40-06-06TC | 3/8 | 10 | 3/8 | 10 | 2.48 | 63 | 1.28 | 33 |
| TR40-08-08TC | 1/2 | 12 | 1/2 | 12 | 2.81 | 71 | 1.34 | 34 |
| TR40-12-12TC | 3/4 | 20 | 3/4 | 20 | 3.44 | 87 | 1.75 | 44 |
| TR40-16-16TC | 1 | 25 | 1 | 25 | 3.61 | 92 | 1.92 | 49 |
| TR40-24-24TC | 1 1/2 | 40 | 1 1/2 | 40 | 5.12 | 130 | 2.43 | 62 |
| TR40-32-32TC | 2 | 50 | 2 | 50 | 6.72 | 171 | 3.16 | 80 |

Materials: 316 Stainless Steel. Material ordering codes are found on Page 76
Swagelok™ is a Registered Trademark of Crawford Company

TR40/TR41 PTFE Hose Permanent Fittings

Swivel Flange 150 lbs

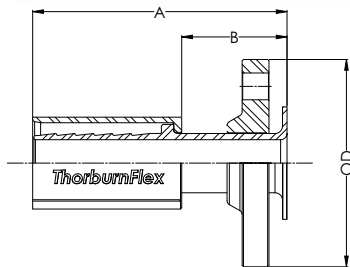

| Part Number | Nominal Flange Size | | A | | B Cutoff Allowance | | Bolt Holes # | Bolt Circle Inch | Stub Flare O.D. | | Flange O.D. | |
|--------------|---------------------|-----|------|-----|--------------------|-----|--------------|------------------|-----------------|-------|-------------|-----|
| | Inch | mm | Inch | mm | Inch | mm | | | Inch | mm | Inch | mm |
| TR40-08-08LF | 1/2 | 12 | 2.9 | 74 | 1.40 | 36 | 4 | 2.38 | 1.37 | 34.9 | 3.50 | 89 |
| TR40-12-12LF | 3/4 | 20 | 3.1 | 79 | 1.50 | 38 | 4 | 2.75 | 1.69 | 42.9 | 2.75 | 70 |
| TR40-16-16LF | 1 | 25 | 3.4 | 86 | 1.65 | 42 | 4 | 2.13 | 2.00 | 50.8 | 3.13 | 79 |
| TR40-20-20LF | 1 1/4 | 30 | 3.9 | 99 | 1.68 | 43 | 4 | 3.50 | 2.50 | 63.5 | 4.63 | 118 |
| TR40-24-24LF | 1 1/2 | 40 | 4.0 | 102 | 1.85 | 47 | 4 | 3.98 | 2.87 | 73.0 | 5.00 | 127 |
| TR40-32-32LF | 2 | 50 | 5.7 | 145 | 2.70 | 69 | 4 | 4.75 | 3.63 | 92.1 | 6.00 | 152 |
| TR40-48-48LF | 3 | 75 | 6.0 | 152 | 2.90 | 74 | 4 | 6.00 | 5.00 | 127.0 | 7.50 | 191 |
| TR40-64-64LF | 4 | 100 | 7.0 | 178 | 3.50 | 89 | 8 | 7.50 | 6.19 | 157.2 | 9.00 | 229 |
| TR40-96-96LF | 6 | 150 | 9.0 | 229 | 4.00 | 102 | 8 | 9.50 | 8.50 | 215.9 | 11.0 | 279 |

Materials: 316 Stainless Steel. Material ordering codes are found on Page 76

Swivel Flange PN10/PN16

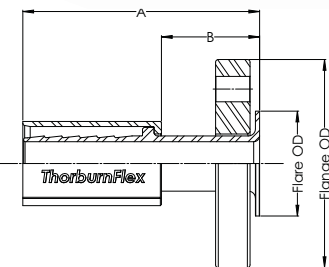

| Part Number | Nominal Flange Size | | A | | B Cutoff Allowance | | Bolt Holes # | Bolt Circle Inch | Stub Flare O.D. | | Flange O.D. | |
|----------------|---------------------|-----|------|-----|--------------------|-----|--------------|------------------|-----------------|-----|-------------|-----|
| | Inch | mm | Inch | mm | Inch | mm | | | Inch | mm | Inch | mm |
| TR40-08-08LFPN | 1/2 | 12 | 2.9 | 74 | 1.40 | 36 | 4 | 2.56 | 1.77 | 45 | 3.74 | 95 |
| TR40-12-12LFPN | 3/4 | 20 | 3.1 | 79 | 1.50 | 38 | 4 | 2.95 | 2.28 | 58 | 4.13 | 105 |
| TR40-16-16LFPN | 1 | 25 | 3.4 | 86 | 1.65 | 42 | 4 | 3.35 | 2.68 | 68 | 4.53 | 115 |
| TR40-20-20LFPN | 1 1/4 | 30 | 3.9 | 99 | 1.68 | 43 | 4 | 3.94 | 3.07 | 78 | 5.51 | 140 |
| TR40-24-24LFPN | 1 1/2 | 40 | 4.0 | 102 | 1.85 | 47 | 4 | 4.33 | 3.46 | 88 | 5.91 | 150 |
| TR40-32-32LFPN | 2 | 50 | 5.7 | 145 | 2.70 | 69 | 4 | 4.92 | 4.02 | 102 | 6.50 | 165 |
| TR40-48-48LFPN | 3 | 75 | 6.0 | 152 | 2.90 | 74 | 8 | 6.30 | 5.43 | 138 | 7.87 | 200 |
| TR40-64-64LFPN | 4 | 100 | 7.0 | 178 | 3.50 | 89 | 8 | 7.09 | 6.22 | 158 | 8.66 | 220 |
| TR40-96-96LFPN | 6 | 150 | 9.0 | 229 | 4.00 | 102 | 8 | 9.45 | 8.35 | 212 | 11.22 | 285 |

Materials: 316 Stainless Steel. Material ordering codes are found on Page 76

Note: Other flange drillings available upon request (ANSI 300lbs, PN10, PN16, PN25).

TR40/TR41 PTFE Hose Permanent Fittings

Tri-Clamp Sanitary Flange

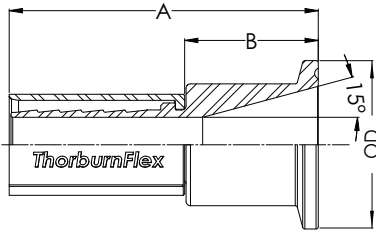

| Part Number | Nominal Hose I.D. | | Nominal Flange Size | | A | | B Cutoff Allowance | | Flange I.D. | | Flange O.D. | |
|---------------|-------------------|-----|---------------------|-----|------|-----|--------------------|----|-------------|----|-------------|-----|
| | Inch | mm | Inch | mm | Inch | mm | Inch | mm | Inch | mm | Inch | mm |
| TR40-16-16STC | 1 | 25 | 1 | 25 | 2.70 | 69 | 1.25 | 32 | 0.87 | 22 | 1.98 | 50 |
| TR40-24-24STC | 1 1/2 | 40 | 1 1/2 | 40 | 3.04 | 77 | 1.25 | 32 | 1.39 | 35 | 1.98 | 50 |
| TR40-32-32STC | 2 | 50 | 2 | 50 | 3.23 | 82 | 1.25 | 32 | 1.87 | 47 | 2.52 | 64 |
| TR40-48-48STC | 3 | 75 | 3 | 75 | 4.65 | 118 | 1.25 | 32 | 2.87 | 73 | 3.58 | 91 |
| TR40-64-64STC | 4 | 100 | 4 | 100 | 5.09 | 129 | 1.25 | 32 | 3.83 | 97 | 4.68 | 119 |

Materials: 316 Stainless Steel. Material ordering codes are found on Page 76

Tapered Tri-Clamp Dust Caps



| Part Number | Nominal Hose I.D. | | Part Number | Nominal Hose I.D. | |
|-------------|-------------------|----|-------------|-------------------|-----|
| | Inch | mm | | Inch | mm |
| TSFC-X-08 | 1/2 | 12 | TSFC-X-32 | 2 | 50 |
| TSFC-X-12 | 3/4 | 20 | TSFC-X-40 | 2 1/2 | 65 |
| TSFC-X-16 | 1 | 25 | TSFC-X-48 | 3 | 75 |
| TSFC-X-24 | 1 1/2 | 40 | TSFC-X-48 | 4 | 100 |

Protect sanitized pipelines and flow equipment from dust, insects, and contamination with snap-on style end dust caps. Made from durable polypropylene, they ensure system integrity while supporting color-coded facility programs to reduce cross-contamination and improve organization.

Sizes 1/2" to 1":
Clear color only without chain

Sizes 1 1/2" to 3":
Colors: Red, Blue, Grey, Yellow
Chain included

X = Colors - Red (R), Blue (B), Grey (G), Yellow (Y)

Mini Sanitary Flange

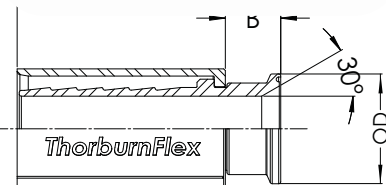

| Part Number | Nominal Hose I.D. | | Nominal Flange Size | | A | | B Cutoff Allowance | | Flange I.D. | | Flange O.D. | |
|---------------|-------------------|----|---------------------|----|------|----|--------------------|----|-------------|-----|-------------|----|
| | Inch | mm | Inch | mm | Inch | mm | Inch | mm | Inch | mm | Inch | mm |
| TR40-08-08MSC | 1/2 | 12 | 1/2 | 12 | 3.07 | 78 | 1.25 | 32 | 0.38 | 9.7 | 0.98 | 24 |
| TR40-12-12MSC | 3/4 | 20 | 3/4 | 20 | 3.19 | 81 | 1.25 | 32 | 0.63 | 16 | 0.98 | 24 |

Materials: 316 Stainless Steel. Material ordering codes are found on Page 76

TR40/TR41 PTFE Hose Permanent Fittings

Swivel Flange 150 lbs Encapsulated

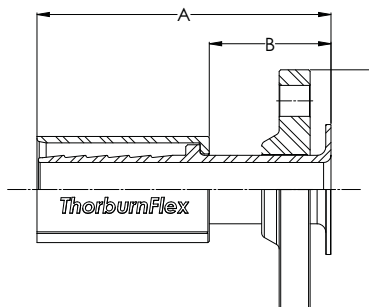

| Part Number | Nominal Hose I.D. | | Nominal Flange Size | | A | | B Cutoff Allowance | | Bolt Circle | | Flange O.D. | |
|------------------|-------------------|-----|---------------------|-----|------|-----|--------------------|-----|-------------|-----|-------------|-----|
| | Inch | mm | Inch | mm | Inch | mm | Inch | mm | Inch | mm | Inch | mm |
| TR40-08-08FL150E | 1/2 | 12 | 1/2 | 12 | 3.1 | 79 | 1.3 | 33 | 2.4 | 61 | 3.5 | 89 |
| TR40-12-12FL150E | 3/4 | 20 | 3/4 | 20 | 3.2 | 81 | 1.4 | 36 | 2.8 | 71 | 3.9 | 99 |
| TR40-16-16FL150E | 1 | 25 | 1 | 25 | 3.4 | 86 | 1.5 | 38 | 3.1 | 79 | 4.3 | 109 |
| TR40-20-20FL150E | 1 1/4 | 30 | 1 1/4 | 30 | 3.5 | 89 | 1.5 | 38 | 3.5 | 89 | 4.6 | 117 |
| TR40-24-24FL150E | 1 1/4 | 40 | 1 1/4 | 40 | 3.7 | 94 | 1.6 | 41 | 3.9 | 99 | 5.0 | 127 |
| TR40-32-32FL150E | 2 | 50 | 2 | 50 | 4.1 | 104 | 1.8 | 46 | 4.8 | 122 | 6.0 | 152 |
| TR40-48-48FL150E | 3 | 75 | 3 | 75 | 5.6 | 142 | 2.5 | 64 | 6 | 152 | 7.5 | 191 |
| TR40-64-64FL150E | 4 | 100 | 4 | 100 | 6.2 | 157 | 3 | 76 | 7.5 | 191 | 9 | 229 |
| TR40-96-96FL150E | 6 | 150 | 6 | 150 | 7.5 | 191 | 4 | 102 | 9.5 | 241 | 11 | 279 |

Materials: 316 Stainless Steel insert encapsulated with PTFE. Material ordering codes are found on Page 76
Note: Other flange drillings available upon request (ANSI 300lbs, PN10, PN16, PN25).

Tri-Clamp Sanitary Flange Encapsulated

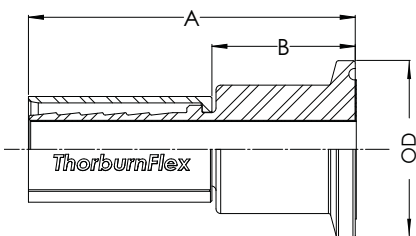

| Part Number | Nominal Hose I.D. | | Nominal Flange Size | | A | | B Cutoff Allowance | | Flange I.D. | | Flange O.D. | |
|----------------|-------------------|-----|---------------------|-----|------|-----|--------------------|----|-------------|----|-------------|-----|
| | Inch | mm | Inch | mm | Inch | mm | Inch | mm | Inch | mm | Inch | mm |
| TR40-16-16STCE | 1 | 25 | 1 | 25 | 2.70 | 69 | 1.25 | 32 | 0.87 | 22 | 1.98 | 50 |
| TR40-24-24STCE | 1 1/2 | 40 | 1 1/2 | 40 | 3.04 | 77 | 1.25 | 32 | 1.39 | 35 | 1.98 | 50 |
| TR40-32-32STCE | 2 | 50 | 2 | 50 | 3.23 | 82 | 1.25 | 32 | 1.87 | 47 | 2.52 | 64 |
| TR40-48-48STCE | 3 | 75 | 3 | 75 | 4.65 | 118 | 1.25 | 32 | 2.87 | 73 | 3.58 | 91 |
| TR40-64-64STCE | 4 | 100 | 4 | 100 | 5.09 | 129 | 1.25 | 32 | 3.83 | 97 | 4.68 | 119 |

Materials: 316 Stainless Steel insert encapsulated with PTFE. Material ordering codes are found on Page 76
Note: Other flange drillings available upon request (ANSI 300lbs, PN10, PN16, PN25).

TR40/TR41 PTFE Hose Permanent Fittings

Mini Sanitary Flange Encapsulated



| Part Number | Nominal Hose I.D. | | Nominal Flange Size | | A | | B Cutoff Allowance | | Flange I.D. | | Flange O.D. | |
|----------------|-------------------|----|---------------------|----|------|----|--------------------|----|-------------|-----|-------------|----|
| | Inch | mm | Inch | mm | Inch | mm | Inch | mm | Inch | mm | Inch | mm |
| TR40-08-08MSCE | 1/2 | 12 | 1/2 | 12 | 3.07 | 78 | 1.25 | 32 | 0.38 | 9.7 | 0.98 | 24 |
| TR40-12-12MSCE | 3/4 | 20 | 3/4 | 20 | 3.19 | 81 | 1.25 | 32 | 0.63 | 16 | 0.98 | 24 |

Materials: 316 Stainless Steel insert encapsulated with PTFE. Material ordering codes are found on Page 76
Note: Other flange drillings available upon request (ANSI 300lbs, PN10, PN16, PN25).

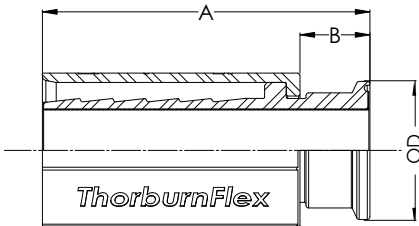

Female "Type C" Cam & Groove Couplings



| Part Number | Nominal Hose I.D. | | Fitting Size | | A | | B Cutoff Allowance | | C O.D. | | D Ext Cam Arms | |
|-------------|-------------------|-----|--------------|-----|-------|-----|--------------------|-----|--------|-----|----------------|-----|
| | Inch | mm | Inch | mm | Inch | mm | Inch | mm | Inch | mm | Inch | mm |
| TR40-08-08C | 1/2 | 12 | 1/2 | 12 | 4.00 | 100 | 2.50 | 64 | 2.11 | 54 | 4.51 | 115 |
| TR40-12-12C | 3/4 | 20 | 3/4 | 20 | 4.25 | 108 | 2.50 | 64 | 2.11 | 54 | 4.51 | 115 |
| TR40-16-16C | 1 | 25 | 1 | 25 | 4.75 | 121 | 3.00 | 75 | 2.44 | 62 | 5.10 | 130 |
| TR40-24-24C | 1 1/2 | 40 | 1 1/2 | 40 | 6.25 | 159 | 3.50 | 89 | 3.56 | 90 | 7.16 | 182 |
| TR40-32-32C | 2 | 50 | 2 | 50 | 7.50 | 191 | 4.00 | 100 | 3.94 | 100 | 7.54 | 192 |
| TR40-48-48C | 3 | 75 | 3 | 75 | 8.00 | 202 | 4.50 | 114 | 5.46 | 139 | 9.56 | 243 |
| TR40-64-64C | 4 | 100 | 4 | 100 | 8.25 | 210 | 4.75 | 121 | 6.56 | 167 | 10.56 | 271 |
| TR40-96-96C | 6 | 150 | 6 | 150 | 10.25 | 260 | 6.00 | 152 | 10.16 | 258 | 16.26 | 413 |

Materials: 316 Stainless Steel. Material ordering codes are found on Page 76

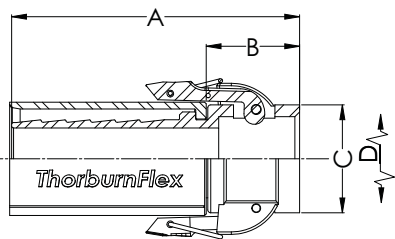

TR40/TR41 PTFE Hose Permanent Fittings

Male “Type E” Cam & Groove Couplings

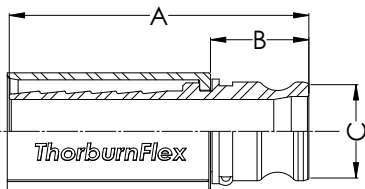

| Part Number | Nominal Hose I.D. | | Fitting Size | | A | | B Cutoff Allowance | | C O.D. | |
|-------------|-------------------|-----|--------------|-----|-------|-----|--------------------|-----|--------|-----|
| | Inch | mm | Inch | mm | Inch | mm | Inch | mm | Inch | mm |
| TR40-08-08E | 1/2 | 12 | 1/2 | 12 | 4.50 | 114 | 3.00 | 75 | 1.26 | 32 |
| TR40-12-12E | 3/4 | 20 | 3/4 | 20 | 4.75 | 121 | 3.00 | 75 | 1.26 | 32 |
| TR40-16-16E | 1 | 25 | 1 | 25 | 5.25 | 133 | 3.50 | 89 | 1.63 | 41 |
| TR40-24-24E | 1 1/2 | 40 | 1 1/2 | 40 | 6.75 | 171 | 4.00 | 100 | 2.14 | 54 |
| TR40-32-32E | 2 | 50 | 2 | 50 | 8.03 | 204 | 4.50 | 114 | 2.64 | 67 |
| TR40-48-48E | 3 | 75 | 3 | 75 | 8.75 | 222 | 5.25 | 133 | 3.70 | 94 |
| TR40-64-64E | 4 | 100 | 4 | 100 | 9.00 | 229 | 5.50 | 140 | 4.71 | 120 |
| TR40-96-96E | 6 | 150 | 6 | 150 | 11.00 | 279 | 6.7 | 170 | 7.09 | 180 |

Materials: 316 Stainless Steel. Material ordering codes are found on Page 76

Female “Type C” Cam & Groove Encapsulated Couplings

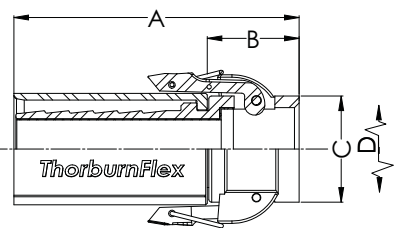

| Part Number | Nominal Hose I.D. | | Fitting Size | | A | | B Cutoff Allowance | | C O.D. | | D Ext. Cam Arms | |
|--------------|-------------------|-----|--------------|-----|-------|-----|--------------------|-----|--------|-----|-----------------|-----|
| | Inch | mm | Inch | mm | Inch | mm | Inch | mm | Inch | mm | Inch | mm |
| TR40-08-08CE | 1/2 | 12 | 1/2 | 12 | 4.00 | 100 | 2.50 | 64 | 2.11 | 54 | 4.51 | 115 |
| TR40-12-12CE | 3/4 | 20 | 3/4 | 20 | 4.25 | 108 | 2.50 | 64 | 2.11 | 54 | 4.51 | 115 |
| TR40-16-16CE | 1 | 25 | 1 | 25 | 4.75 | 121 | 3.00 | 75 | 2.44 | 62 | 5.10 | 130 |
| TR40-24-24CE | 1 1/2 | 40 | 1 1/2 | 40 | 6.25 | 159 | 3.50 | 89 | 3.56 | 90 | 7.16 | 182 |
| TR40-32-32CE | 2 | 50 | 2 | 50 | 7.50 | 191 | 4.00 | 100 | 3.94 | 100 | 7.54 | 192 |
| TR40-48-48CE | 3 | 75 | 3 | 75 | 8.00 | 202 | 4.50 | 114 | 5.46 | 139 | 9.56 | 243 |
| TR40-64-64CE | 4 | 100 | 4 | 100 | 8.25 | 210 | 4.75 | 121 | 6.56 | 167 | 10.56 | 271 |
| TR40-96-96CE | 6 | 150 | 6 | 150 | 10.25 | 260 | 6.00 | 152 | 10.16 | 258 | 16.26 | 413 |

Materials: 316 Stainless Steel insert encapsulated with PTFE. Material ordering codes are found on Page 76

TR40/TR41 PTFE Hose Permanent Fittings

Male “Type E” Cam & Groove Encapsulated Couplings

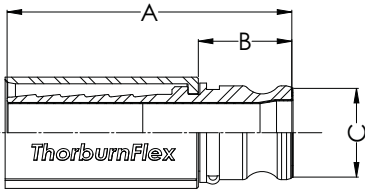

| Part Number | Nominal Hose I.D. | | Fitting Size | | A | | B Cutoff Allowance | | C O.D. | |
|--------------|-------------------|-----|--------------|-----|-------|-----|--------------------|-----|--------|-----|
| | Inch | mm | Inch | mm | Inch | mm | Inch | mm | Inch | mm |
| TR40-08-08EE | 1/2 | 12 | 1/2 | 12 | 4.50 | 114 | 3.00 | 75 | 1.26 | 32 |
| TR40-12-12EE | 3/4 | 20 | 3/4 | 20 | 4.75 | 121 | 3.00 | 75 | 1.26 | 32 |
| TR40-16-16EE | 1 | 25 | 1 | 25 | 5.25 | 133 | 3.50 | 89 | 1.63 | 41 |
| TR40-24-24EE | 1 1/2 | 40 | 1 1/2 | 40 | 6.75 | 171 | 4.00 | 100 | 2.14 | 54 |
| TR40-32-32EE | 2 | 50 | 2 | 50 | 8.03 | 204 | 4.50 | 114 | 2.64 | 67 |
| TR40-48-48EE | 3 | 75 | 3 | 75 | 8.75 | 222 | 5.25 | 133 | 3.70 | 94 |
| TR40-64-64EE | 4 | 100 | 4 | 100 | 9.00 | 229 | 5.50 | 140 | 4.71 | 120 |
| TR40-96-96EE | 6 | 150 | 6 | 150 | 11.00 | 279 | 6.7 | 170 | 7.09 | 180 |

Materials: 316 Stainless Steel insert encapsulated with PTFE. Material ordering codes are found on Page 76

Female “Type C” Cam & Groove Polypropylene Couplings

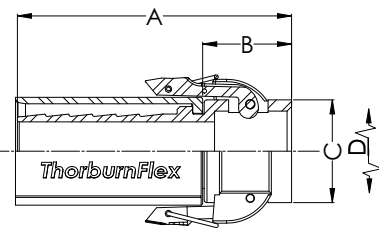

| Part Number | Nominal Hose I.D. | | Fitting Size | | A | | B Cutoff Allowance | | C O.D. | | D Ext. Cam Arms | |
|--------------|-------------------|-----|--------------|-----|-------|-----|--------------------|-----|--------|-----|-----------------|-----|
| | Inch | mm | Inch | mm | Inch | mm | Inch | mm | Inch | mm | Inch | mm |
| TR40-08-08CP | 1/2 | 12 | 1/2 | 12 | 4.00 | 100 | 2.50 | 64 | 2.11 | 54 | 4.51 | 115 |
| TR40-12-12CP | 3/4 | 20 | 3/4 | 20 | 4.25 | 108 | 2.50 | 64 | 2.11 | 54 | 4.51 | 115 |
| TR40-16-16CP | 1 | 25 | 1 | 25 | 4.75 | 121 | 3.00 | 75 | 2.44 | 62 | 5.10 | 130 |
| TR40-24-24CP | 1 1/2 | 40 | 1 1/2 | 40 | 6.25 | 159 | 3.50 | 89 | 3.56 | 90 | 7.16 | 182 |
| TR40-32-32CP | 2 | 50 | 2 | 50 | 7.50 | 191 | 4.00 | 100 | 3.94 | 100 | 7.54 | 192 |
| TR40-48-48CP | 3 | 75 | 3 | 75 | 8.00 | 202 | 4.50 | 114 | 5.46 | 139 | 9.56 | 243 |
| TR40-64-64CP | 4 | 100 | 4 | 100 | 8.25 | 210 | 4.75 | 121 | 6.56 | 167 | 10.56 | 271 |
| TR40-96-96CP | 6 | 150 | 6 | 150 | 10.25 | 260 | 6.00 | 152 | 10.16 | 258 | 16.26 | 413 |

Materials: 316 Stainless Steel Ferrule with Polypropylene insert. Material ordering codes are found on Page 76
 Maximum Pressure: 90 PSI - 3/4" (20 mm) to 2" (50 mm) | 50 PSI - 3" (75 mm) to 4" (100 mm)
 Maximum Temperature: 60°C (140°F)

TR40/TR41 PTFE Hose Permanent Fittings

Male “Type E” Cam & Groove Polypropylene Couplings

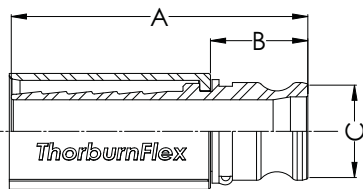

| Part Number | Nominal Hose I.D. | | Fitting Size | | A | | B Cutoff Allowance | | C O.D. | |
|--------------|-------------------|-----|--------------|-----|-------|-----|--------------------|-----|--------|-----|
| | Inch | mm | Inch | mm | Inch | mm | Inch | mm | Inch | mm |
| TR40-08-08EP | 1/2 | 12 | 1/2 | 12 | 4.50 | 114 | 3.00 | 75 | 1.26 | 32 |
| TR40-12-12EP | 3/4 | 20 | 3/4 | 20 | 4.75 | 121 | 3.00 | 75 | 1.26 | 32 |
| TR40-16-16EP | 1 | 25 | 1 | 25 | 5.25 | 133 | 3.50 | 89 | 1.63 | 41 |
| TR40-24-24EP | 1 1/2 | 40 | 1 1/2 | 40 | 6.75 | 171 | 4.00 | 100 | 2.14 | 54 |
| TR40-32-32EP | 2 | 50 | 2 | 50 | 8.03 | 204 | 4.50 | 114 | 2.64 | 67 |
| TR40-48-48EP | 3 | 75 | 3 | 75 | 8.75 | 222 | 5.25 | 133 | 3.70 | 94 |
| TR40-64-64EP | 4 | 100 | 4 | 100 | 9.00 | 229 | 5.50 | 140 | 4.71 | 120 |
| TR40-96-96EP | 6 | 150 | 6 | 150 | 11.00 | 279 | 6.7 | 170 | 7.09 | 180 |

Materials: 316 Stainless Steel Ferrule with Polypropylene insert. Material ordering codes are found on Page 76
 Maximum Pressure: 90 PSI - 3/4" (20 mm) to 2" (50 mm) | 50 PSI - 3" (75 mm) to 4" (100 mm)
 Maximum Temperature: 60°C (140°F)

Polypropylene Hex Male Pipe

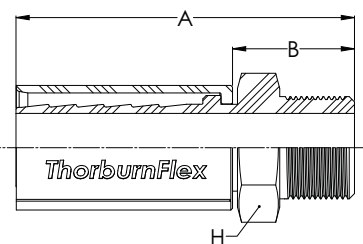

| Part Number | Nominal Hose I.D. | | Fitting Size | | Thread Size | A | | B Cutoff Allowance | | H Hex |
|---------------|-------------------|----|--------------|----|--------------|------|----|--------------------|----|-------|
| | Inch | mm | Inch | mm | | Inch | mm | Inch | mm | Inch |
| TR40-12-12MPP | 3/4 | 20 | 3/4 | 20 | 3/4-14 | 3.00 | 75 | 1.62 | 41 | 1.13 |
| TR40-16-16MPP | 1 | 25 | 1 | 25 | 1-11 1/2 | 3.27 | 83 | 1.72 | 44 | 1.38 |
| TR40-24-24MPP | 1 1/2 | 40 | 1 1/2 | 40 | 1 1/2-11 1/2 | 3.58 | 91 | 2.07 | 53 | 2.00 |
| TR40-32-32MPP | 2 | 50 | 2 | 50 | 2-11 1/2 | 3.93 | 99 | 2.23 | 57 | 2.50 |

Materials: 316 Stainless Steel Ferrule with Polypropylene insert. Material ordering codes are found on Page 76
 Maximum Pressure: 90 PSI - 3/4" (20 mm) to 2" (50 mm) | 50 PSI - 3" (75 mm) to 4" (100 mm)
 Maximum Temperature: 60°C (140°F)

TR40/TR41 PTFE Hose Permanent Fittings

Polypropylene Tri-Clamp Sanitary Flange



| Part Number | Nominal Hose I.D. | | Nominal Flange Size | | A | | B Cutoff Allowance | | Flange I.D. | | Flange O.D. | |
|----------------|-------------------|----|---------------------|----|------|----|--------------------|----|-------------|----|-------------|----|
| | Inch | mm | Inch | mm | Inch | mm | Inch | mm | Inch | mm | Inch | mm |
| TR40-16-16STCP | 1 | 25 | 1 | 25 | 2.70 | 69 | 1.25 | 32 | 0.87 | 22 | 1.98 | 50 |
| TR40-24-24STCP | 1 1/2 | 40 | 1 1/2 | 40 | 3.04 | 77 | 1.25 | 32 | 1.39 | 35 | 1.98 | 50 |
| TR40-32-32STCP | 2 | 50 | 2 | 50 | 3.23 | 82 | 1.25 | 32 | 1.87 | 47 | 2.52 | 64 |

Materials: 316 Stainless Steel Ferrule with Polypropylene insert. Material ordering codes are found on Page 76
 Maximum Pressure: 90 PSI - 3/4" (20 mm) to 2" (50 mm) | 50 PSI - 3" (75 mm) to 4" (100 mm)
 Maximum Temperature: 60°C (140°F)

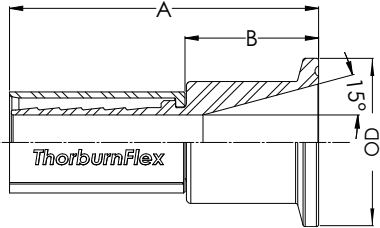

Polypropylene Tube Stub



| Part Number | Nominal Hose I.D. | | Tube O.D. | | A | | B Cutoff Allowance | |
|-------------|-------------------|----|-----------|----|------|-----|--------------------|----|
| | Inch | mm | Inch | mm | Inch | mm | Inch | mm |
| TR40-04-04T | 1/4 | 6 | 1/4 | 6 | 1.96 | 49 | 0.80 | 20 |
| TR40-06-06T | 3/8 | 10 | 3/8 | 10 | 2.42 | 61 | 1.22 | 31 |
| TR40-08-08T | 1/2 | 12 | 1/2 | 12 | 2.91 | 74 | 1.44 | 37 |
| TR40-12-12T | 3/4 | 20 | 3/4 | 20 | 3.53 | 90 | 1.84 | 47 |
| TR40-16-16T | 1 | 25 | 1 | 25 | 3.78 | 96 | 1.94 | 49 |
| TR40-24-24T | 1 1/2 | 40 | 1 1/2 | 40 | 5.22 | 133 | 2.53 | 64 |
| TR40-32-32T | 2 | 50 | 2 | 50 | 6.82 | 173 | 3.26 | 83 |

Materials: 316 Stainless Steel. Material ordering codes are found on Page 76

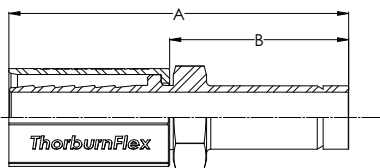

TC72/76 PTFE Hose Assemblies



| TC72 (top) and TC76 Hose Assemblies |

AEROSPACE STANDARDS (on request):

- SAE AS1946, MIL-DTL-25579, MIL-DTL-27267
- TSO C53a Type A
- TSO C53a Type C
- TSO C75 Type IIA-S/P, TSO C75 Type IIA-S/P-F
- AS1055 Type IIa & IIb, Class A & B

APPLICATIONS:

- Chemical loading/unloading
- Food handling
- Pulp & Paper
- Foam packaging
- Waste water
- Batch bulk transfer
- Decanting vessels and drums

Thorburn's **TC72** is a flexible convoluted bore PTFE hose with high tensile stainless steel braided reinforcement that is designed for low force small minimum bend radii, long term flex life, and chemically inert for corrosion resistance. Thorburn's TC72 PTFE hose is ideal for high purity applications, such as pharmaceutical or food transfer.

Thorburn's **TC76** has an antistatic conductive carbon black added to the PTFE to dissipate an electrostatic charge in fuel, steam, or high flow-rate applications. It is an ideal hose for fuel handling, tire presses, laundry presses and other types of steam service where on-off operating cycles cause wide temperature fluctuations inside the hose.

HOSE CONSTRUCTION:

TC72 Inner Core: Convoluted 100% pure PTFE, externally reinforced with PTFE-impregnated fiberglass.

TC76 Inner Core: Convoluted 100% pure PTFE, externally reinforced with PTFE-impregnated fiberglass. Thorburn's TC76 hose has precisely controlled amounts of carbon black added to the inner 15% of the PTFE inner core. This homogeneous material provides a continuous conductive path to the metal end fittings.

REINFORCEMENT: A580 type 304 (EN1.4301) high tensile stainless steel braid.

TEMPERATURE RANGE: -54°C to 204°C (-65°F to 400°F)

STANDARDS:

- SAE AS620
- PTFE meets FDA 21 CFR 177.1550 & ISO 12086 Part 1., USDA and #A
- Meets Pharmacopoeia Class VI DIP & CIP.

| Part Number | Nominal Size | | Nominal I.D. | | Nominal O.D. | | Operating Pressure | | Room Temp. Min. Burst | | Max. Continuous Length | | Min. Bend Radius | | Hose Weight | |
|-------------|--------------|-------|--------------|------|--------------|------|--------------------|------|-----------------------|------|------------------------|----|------------------|------|-------------|-------|
| | DN | in | mm | in | mm | in | bar | psi | bar | psi | m | ft | mm | in | kg/m | lb/ft |
| TC72/76-4 | 8 | 1/4 | 6.10 | 0.24 | 12.2 | 0.48 | 137.9 | 2000 | 599.8 | 8700 | 22.9 | 75 | 17.8 | 0.70 | 0.012 | 0.09 |
| TC72/76-6 | 10 | 3/8 | 9.65 | 0.38 | 15.0 | 0.59 | 103.4 | 1500 | 439.9 | 6380 | 22.9 | 75 | 20.3 | 0.80 | 0.016 | 0.12 |
| TC72/76-8 | 15 | 1/2 | 13.0 | 0.51 | 20.1 | 0.79 | 96.5 | 1400 | 399.9 | 5800 | 22.9 | 75 | 25.4 | 1.00 | 0.030 | 0.22 |
| TC72/76-12 | 20 | 3/4 | 19.1 | 0.75 | 27.9 | 1.10 | 68.9 | 1000 | 275.8 | 4000 | 15.2 | 50 | 50.8 | 2.00 | 0.040 | 0.29 |
| TC72/76-16 | 25 | 1 | 25.4 | 1.00 | 33.0 | 1.30 | 68.9 | 1000 | 275.8 | 4000 | 15.2 | 50 | 76.2 | 3.00 | 0.056 | 0.41 |
| TC72/76-20 | 32 | 1 1/4 | 31.5 | 1.24 | 39.6 | 1.56 | 68.9 | 1000 | 275.8 | 4000 | 15.2 | 50 | 158.8 | 6.25 | 0.073 | 0.53 |
| TC72/76-24 | 40 | 1 1/2 | 38.1 | 1.50 | 45.5 | 1.79 | 51.7 | 750 | 206.8 | 3000 | 15.2 | 50 | 190.5 | 7.50 | 0.085 | 0.62 |
| TC72/76-32 | 50 | 2 | 50.3 | 1.98 | 59.2 | 2.33 | 34.5 | 500 | 137.9 | 2000 | 15.2 | 50 | 254.0 | 10.0 | 0.134 | 0.97 |

Available fitting to end joint hose couplings are found on pages 61 to 71

TC85/87 PTFE Hose Assemblies

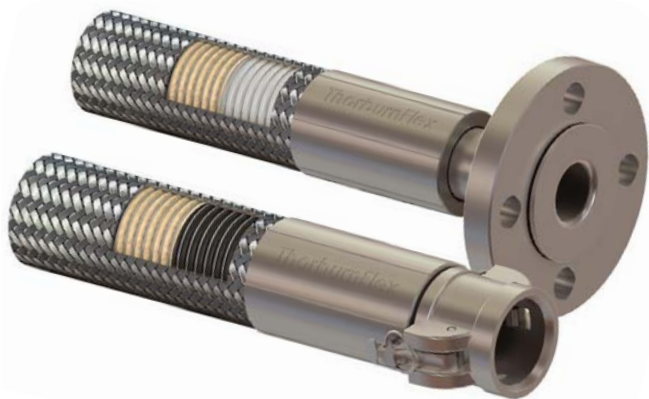

| TC85 (top) and TC87 Hose Assemblies |

STANDARDS: PTFE Meets FDA 21 CFR 177.1550. Meets United States and Canadian Coast Guard specifications.

APPLICATIONS:

TC85 hose assemblies are an ideal bulk transfer hose for a wide range of caustics, chemicals and raw materials.

- Tank, car and ship offloading
- Bulk handling and petrochemical transfer
- Pump connections
- Pulp & Paper
- Vacuum transfer
- Compressor intake

TC87 conductive transfer hose assemblies have the same bulk-handling usefulness as the TC85 with special suitability for high-flow installations involving fuels and other petrochemicals. It has a conductive inner core to effectively dissipate static charges.

Thorburn's TC85 is a heavy wall convoluted bore PTFE hose with an inner spring spiral wire at the root of the convolution for full vacuum and to prevent hose kinking. The pressure containment is provided by a high tensile stainless steel braid that is designed for low force small minimum bend radiuses and long term flex life. Thorburn's TC85 PTFE inner core is chemically inert for corrosion resistance and is also an ideal hose for high purity applications such as pharmaceutical or food transfer.

Thorburn's TC87 has an antistatic conductive carbon black added to the PTFE to dissipate an electrostatic charge in fuel, steam, or high flow-rate applications. It is an ideal hose for fuel handling, tire presses, laundry presses and other types of steam service where on-off operating cycles cause wide temperature fluctuations inside the hose.

HOSE CONSTRUCTION:

TC85 Inner Core: Convoluted 100% pure PTFE, externally reinforced with PTFE-impregnated fiberglass and has an inner spring spiral wire at the root of the convolution for full vacuum and to prevent hose kinking.

TC87 Inner Core: Convoluted 100% pure PTFE, externally reinforced with PTFE-impregnated fiberglass and has an inner spring spiral wire at the root of the convolution for full vacuum and to prevent hose kinking. Thorburn's TC87 hose has precisely controlled amounts of carbon black added to the inner 15% of the PTFE inner core. This homogeneous material provides a continuous conductive path to the metal end fittings.

REINFORCEMENT: A580 type 304 (EN1.4301) high tensile stainless steel braid.

TEMPERATURE RANGE: -54°C to 204°C (-65°F to 400°F)

| Part Number | Nominal Size | | Nominal I.D. | | Nominal O.D. | | Operating Pressure | | Room Temp. Min. Burst | | Max. Continuous Length | | Min. Bend Radius | | Hose Weight | |
|-------------|--------------|-------|--------------|------|--------------|------|--------------------|-----|-----------------------|------|------------------------|----|------------------|------|-------------|-------|
| | DN | in | mm | in | mm | in | bar | psi | bar | psi | m | ft | mm | in | kg/m | lb/ft |
| TC-85/87-24 | 40 | 1 1/2 | 38.6 | 1.52 | 48.3 | 1.90 | 51.7 | 750 | 207 | 3000 | 12.2 | 40 | 190.5 | 7.50 | 1.31 | 0.88 |
| TC-85/87-32 | 50 | 2 | 51.3 | 2.02 | 61.5 | 2.42 | 34.5 | 500 | 138 | 2000 | 12.2 | 40 | 254.0 | 10 | 1.77 | 1.19 |
| TC-85/87-48 | 80 | 3 | 77.5 | 3.05 | 93.5 | 3.68 | 17.2 | 250 | 69 | 1000 | 12.2 | 40 | 381.0 | 15 | 3.42 | 2.30 |
| TC-85/87-64 | 100 | 4 | 103.4 | 4.07 | 123.2 | 4.85 | 10.3 | 150 | 41 | 600 | 12.2 | 40 | 609.6 | 24 | 5.18 | 3.48 |
| TC-85/87-96 | 150 | 6 | 130.0 | 5.12 | 149.1 | 5.87 | 5.3 | 75 | 21 | 300 | 12.2 | 40 | 900.0 | 35 | 12.0 | 8.04 |

Available fitting to end joint hose couplings are found on pages 61 to 71

TC92/TC96 PTFE Hose Assemblies



| TC92 (top) and TC96 Hose Assemblies |

Thorburn’s **TC92** white and **TC96** conductive static dissipating PTFE lined seamless convoluted hose offers greater hose flexibility, reduces kinking and allows the hose to self drain more easily. TC92-TC96 hoses are designed to withstand the most demanding conditions, including high velocity and pressure surges.

HOSE CONSTRUCTION:

The unique features of Thorburn’s TC92 & TC96 inner cores thick tube design is its ability to be extended through the fittings and flare over sealing failures— thus resulting in no exposed sealing surfaces for greater relief from leaking, corrosion and bacteria startup.

- TC92 white PTFE 316SS braid
- TC96 conductive PTFE 316SS braid

TEMPERATURE RANGE: -73°C to 232°C (-100°F to 450°F) - Braid A580 type SS304 standard optional SS316

APPLICATIONS:

- Chemical transfer
- Pharmaceuticals
- Food and Beverage
- Pulp & Paper
- Foam packaging
- Tire press
- Air compressor discharge

| Part Number | Nominal Size | | Nominal I.D. | | Nominal O.D. | | Operating Pressure | | Room Temp. Min. Burst | | Max. Continuous Length | | Min. Bend Radius | | Hose Weight | |
|--------------|--------------|-------|--------------|------|--------------|------|--------------------|------|-----------------------|------|------------------------|----|------------------|------|-------------|-------|
| | DN | in | mm | in | mm | in | bar | psi | bar | psi | m | ft | mm | in | kg/m | lb/ft |
| TC92/TC96-4 | 8 | 1/4 | 6.09 | 0.24 | 10.67 | 0.42 | 138 | 2000 | 600 | 8700 | 18 | 60 | 21.6 | 0.85 | 0.13 | 0.09 |
| TC92/TC96-6 | 10 | 3/8 | 9.65 | 0.38 | 16.51 | 0.65 | 110 | 1600 | 469 | 6800 | 18 | 60 | 25.0 | 1.00 | 0.18 | 0.12 |
| TC92/TC96-8 | 15 | 1/2 | 12.70 | 0.50 | 17.53 | 0.69 | 103 | 1500 | 414 | 6000 | 18 | 60 | 44.5 | 1.75 | 0.32 | 0.21 |
| TC92/TC96-12 | 20 | 3/4 | 19.05 | 0.75 | 25.91 | 1.02 | 83 | 1200 | 331 | 4800 | 18 | 60 | 69.9 | 2.75 | 0.48 | 0.32 |
| TC92/TC96-16 | 25 | 1 | 25.40 | 1.00 | 34.04 | 1.43 | 69 | 1000 | 276 | 4000 | 18 | 60 | 88.9 | 3.50 | 0.65 | 0.48 |
| TC92/TC96-20 | 32 | 1 1/4 | 31.75 | 1.25 | 40.13 | 1.58 | 52 | 750 | 221 | 3200 | 18 | 60 | 114.3 | 4.50 | 1.06 | 0.71 |
| TC92/TC96-24 | 40 | 1 1/2 | 38.10 | 1.50 | 48.01 | 1.89 | 45 | 650 | 179 | 2600 | 17 | 55 | 120.7 | 4.75 | 1.17 | 0.78 |
| TC92/TC96-32 | 50 | 2 | 50.80 | 2.00 | 60.45 | 2.38 | 31 | 450 | 145 | 2100 | 13 | 42 | 133.4 | 5.25 | 1.59 | 1.09 |
| TC92/TC96-48 | 80 | 3 | 76.2 | 3.00 | 125.7 | 4.95 | 17 | 250 | 69 | 1000 | 9.5 | 30 | 241.3 | 9.50 | 4.32 | 2.90 |

Available fitting to end joint hose couplings are found on pages 61 to 71

TC97/TC98 PTFE Hose Assemblies



| TC97 (top) and TC98 Hose Assemblies |

APPLICATIONS:

- Chemical transfer
- Pharmaceuticals
- Food and beverage
- Pulp & Paper
- Foam packaging
- Tire press
- Air compressor discharge

Thorburn's **TC97** white and **TC98** conductive static dissipating PTFE lined seamless convoluted hose offers greater hose flexibility, reduces kinking and allows the hose to self drain more easily. TC97-TC98 hoses are designed to withstand the most demanding conditions, including high velocity and pressure surges.

HOSE CONSTRUCTION:

The unique features of Thorburn's TC97 & TC98 inner cores thick tube design is its ability to be extended through the fittings and flare over sealing failures— thus resulting in no exposed sealing surfaces for greater relief from leaking, corrosion and bacteria startup.

Polypropylene Braid

Fraying of braid will not puncture handler's hands. Maximum abrasion and chemical resistance.

- TC97 white PTFE polypropylene braid
- TC98 conductive PTFE polypropylene braid

TEMPERATURE RANGE:

Polypropylene Braided Hose

-40°C to 121°C (-40°F to 250°F) - Tightly woven polypropylene braid

-73°C to 232°C (-100°F to 450°F) - Braid A580 type SS304 standard optional SS316

| Part Number | Nominal Size | | Nominal I.D. | | Nominal O.D. | | Operating Pressure | | Room Temp. Min. Burst | | Max. Continuous Length | | Min. Bend Radius | | Hose Weight | |
|--------------|--------------|-------|--------------|------|--------------|------|--------------------|-----|-----------------------|------|------------------------|----|------------------|------|-------------|-------|
| | DN | in | mm | in | mm | in | bar | psi | bar | psi | m | ft | mm | in | kg/m | lb/ft |
| TC97/TC98-4 | 8 | 1/4 | 6.3 | 0.25 | 13.9 | 0.55 | 24 | 350 | 97 | 1400 | 18 | 60 | 19.0 | 0.75 | 0.05 | 0.03 |
| TC97/TC98-6 | 10 | 3/8 | 9.5 | 0.38 | 16.3 | 0.64 | 24 | 350 | 97 | 1400 | 18 | 60 | 25.4 | 1.00 | 0.09 | 0.06 |
| TC97/TC98-8 | 15 | 1/2 | 12.7 | 0.50 | 24.1 | 0.95 | 24 | 350 | 83 | 1200 | 18 | 60 | 44.5 | 1.75 | 0.17 | 0.12 |
| TC97/TC98-12 | 20 | 3/4 | 19.1 | 0.75 | 32.3 | 1.27 | 17 | 250 | 69 | 1000 | 18 | 60 | 57.2 | 2.25 | 0.37 | 0.25 |
| TC97/TC98-16 | 25 | 1 | 25.4 | 1.00 | 39.6 | 1.56 | 17 | 250 | 69 | 1000 | 18 | 60 | 69.9 | 2.75 | 0.45 | 0.30 |
| TC97/TC98-24 | 40 | 1 1/2 | 38.1 | 1.50 | 51.1 | 2.01 | 14 | 200 | 55 | 800 | 13 | 42 | 177.8 | 7.0 | 0.79 | 0.53 |
| TC97/TC98-32 | 50 | 2 | 50.8 | 2.00 | 64.8 | 2.55 | 14 | 200 | 55 | 800 | 12 | 40 | 228.6 | 9.0 | 1.34 | 0.90 |
| TC97/TC98-48 | 80 | 3 | 76.2 | 3.00 | 95.3 | 3.75 | 10 | 150 | 41 | 600 | 11 | 35 | 254.0 | 10.0 | 2.11 | 1.42 |

Available fitting to end joint hose couplings are found on pages 61 to 71

TC29/TC30 PTFE Hose Assemblies



| TC29 (top) and TC30 Hose Assemblies |

APPLICATIONS:

- Compressed air lines in aluminum smelters
- Coolant
- Fuel
- Oil
- Instrument lines
- Medium pressure gas systems

Thorburn's **TC30** is specifically designed for long term service as the flexible component used to transfer compressed air to pneumatic control valves and crust breaker/feeder cylinders found in potroom superstructures of aluminum smelters. TC30 is non-conductive with tight sealing to 275 bar and its properties do not change over time, having superior maintenance free performance.

Thorburn's **TC29** hose is similar to Thorburn's TC30 hose except it has 15% carbon black added to the PTFE to dissipate electrical static charge.

FEATURES:

- Non-metallic, non-conductive throughout and flame resistant (will not sustain combustion) characteristics make it suitable for sound attenuation, electrical insulation, isolation or resistance to high frequency radiation.
- High tensile strength Aramid braid makes it suitable for higher temperatures and pressures than Nomex-nylon braided hoses.
- Is lightweight, extremely flexible and is ideal for high pressure dielectric superstructure potroom hose.

HOSE CONSTRUCTION:

Inner Core: Virgin white convoluted PTFE

REINFORCEMENT: PTFE-impregnated fiberglass and a double Aramid braid, covered with a flame retardant abrasive resistant polyester braid, specifically designed to protect the Aramid braid from UV degradation.

TEMPERATURE RANGE: -54°C to 175°C (-65°F to 350°F)
-73°C to 204°C (-100°F to 400°F) intermittent service

STANDARDS:

Meets United States and Canadian Coast Guard specifications.

| Part Number | Nominal Size | | Nominal I.D. | | Nominal O.D. | | Operating Pressure | | Room Temp. Min. Burst | | Max. Continuous Length | | Min. Bend Radius | | Hose Weight | |
|-------------|--------------|-------|--------------|------|--------------|------|--------------------|------|-----------------------|------|------------------------|----|------------------|------|-------------|-------|
| | DN | in | mm | in | mm | in | bar | psi | bar | psi | m | ft | mm | in | kg/m | lb/ft |
| TC30-4 | 8 | 1/4 | 6.35 | 0.25 | 11.94 | 0.47 | 68.9 | 1000 | 275.8 | 4000 | 22.9 | 75 | 12.7 | 0.50 | 0.067 | 0.045 |
| TC30-6 | 10 | 3/8 | 9.65 | 0.38 | 14.5 | 0.57 | 68.9 | 1000 | 275.8 | 4000 | 22.9 | 75 | 19.1 | 0.75 | 0.091 | 0.061 |
| TC30-8 | 15 | 1/2 | 12.7 | 0.50 | 19.6 | 0.77 | 68.9 | 1000 | 275.8 | 4000 | 15.2 | 50 | 25.4 | 1.00 | 0.185 | 0.124 |
| TC30-12 | 20 | 3/4 | 19.1 | 0.75 | 25.7 | 1.01 | 68.9 | 1000 | 275.8 | 4000 | 9.14 | 30 | 50.8 | 2.00 | 0.274 | 0.184 |
| TC30-16 | 25 | 1 | 25.4 | 1.00 | 33.3 | 1.31 | 68.9 | 1000 | 275.8 | 4000 | 9.14 | 30 | 76.2 | 3.00 | 0.357 | 0.240 |
| TC30-20 | 32 | 1 1/4 | 31.8 | 1.25 | 39.1 | 1.54 | 51.7 | 750 | 206.8 | 3000 | 9.14 | 30 | 88.9 | 3.50 | 0.399 | 0.268 |
| TC30-24 | 40 | 1 1/2 | 38.1 | 1.50 | 45.7 | 1.80 | 43.1 | 625 | 172.4 | 2500 | 9.14 | 30 | 101.6 | 4.00 | 0.521 | 0.350 |
| TC30-32 | 50 | 2 | 50.8 | 2.00 | 59.4 | 2.34 | 43.1 | 625 | 172.4 | 2500 | 9.14 | 30 | 152.4 | 6.00 | 0.595 | 0.400 |

Available fitting to end joint hose couplings are found on pages 61 to 71

TC31/TC32 PTFE Hose Couplings



| TC31 (top) and TC32 Hose Assemblies |

APPLICATIONS:

- Compressed air lines in aluminum smelters
- Potroom
- Coolant
- Fuel
- Oil
- Instrument lines
- Medium pressure gas systems

Thorburn's **TC31** hose has an abrasive resistant polyester braid reinforcement instead of wire braid, is non-metallic throughout, and flame-resistant (will not sustain combustion). These characteristics make it appropriate for many uses requiring sound attenuation, electrical insulation or isolation, or resistance to high frequency radiation (which may cause external overheating and eventual failure of metal-braided hose). TC31 has 15% carbon black added to the PTFE to dissipate electrical static charge. Typical applications include coolant lines, fuel and oil hose, instrument lines and low pressure industrial gas compressed air systems.

Thorburn's **TC32** hose has a polyester braid and is similar to TC31, except that the PTFE inner core is white and does not possess the static dissipation characteristics of the carbon black inner core. This is an economical alternative to Thorburn TC30 Potroom hose.

FEATURES:

- Available with conductive or non-conductive core
- Ideal dielectric medium pressure Superstructure Potroom hose

HOSE CONSTRUCTION:

INNER CORE: Convoluted PTFE

REINFORCEMENT: PTFE-impregnated fiberglass and polyester or Nomex nylon braid

TEMPERATURE RANGE: -54°C to 135°C (-65°F to 275°F)

STANDARDS:

Meets United States and Canadian Coast Guard specifications.

| Part Number | Nominal Size | | Nominal I.D. | | Nominal O.D. | | Operating Pressure | | Room Temp. Min. Burst | | Max. Continuous Length | | Min. Bend Radius | | Hose Weight | |
|--------------|--------------|-------|--------------|------|--------------|------|--------------------|-----|-----------------------|------|------------------------|----|------------------|------|-------------|-------|
| | DN | in | mm | in | mm | in | bar | psi | bar | psi | m | ft | mm | in | kg/m | lb/ft |
| TC31/TC32-4 | 8 | 1/4 | 6.35 | 0.25 | 11.94 | 0.47 | 34.5 | 500 | 165.5 | 2400 | 22.9 | 75 | 12.7 | 0.50 | 0.059 | 0.040 |
| TC31/TC32-6 | 10 | 3/8 | 9.65 | 0.38 | 14.5 | 0.57 | 34.5 | 500 | 165.5 | 2400 | 22.9 | 75 | 19.1 | 0.75 | 0.074 | 0.050 |
| TC31/TC32-8 | 15 | 1/2 | 12.7 | 0.50 | 19.6 | 0.77 | 34.5 | 500 | 165.5 | 2400 | 15.2 | 50 | 25.4 | 1.00 | 0.185 | 0.124 |
| TC31/TC32-12 | 20 | 3/4 | 19.1 | 0.75 | 25.7 | 1.01 | 27.6 | 400 | 151.6 | 2200 | 9.14 | 30 | 38.1 | 1.50 | 0.260 | 0.175 |
| TC31/TC32-16 | 25 | 1 | 25.4 | 1.00 | 33.3 | 1.31 | 24.1 | 350 | 131.0 | 1900 | 9.14 | 30 | 50.8 | 2.00 | 0.298 | 0.200 |
| TC31/TC32-20 | 32 | 1 1/4 | 31.8 | 1.25 | 39.1 | 1.54 | 20.7 | 300 | 110.3 | 1600 | 9.14 | 30 | 88.9 | 3.50 | 0.372 | 0.250 |
| TC31/TC32-24 | 40 | 1 1/2 | 38.1 | 1.50 | 45.7 | 1.80 | 17.2 | 250 | 82.7 | 1200 | 9.14 | 30 | 101.6 | 4.00 | 0.505 | 0.340 |
| TC31/TC32-32 | 50 | 2 | 50.8 | 2.00 | 59.4 | 2.34 | 10.3 | 150 | 44.8 | 650 | 9.14 | 30 | 152.4 | 6.00 | 0.595 | 0.400 |

Available fitting to end joint hose couplings are found on pages 61 to 71

TC33/TC34 PTFE Hose Couplings



| TC33 (top) and TC34 Hose Assemblies |

APPLICATIONS:

- Compressed air lines in aluminum smelters
- Potroom
- Coolant
- Fuel
- Oil
- Instrument lines
- Medium pressure gas systems

Thorburn's **TC33** is reinforced with a Dupont Nomex braid and has 15% carbon black added to the PTFE inner core to dissipate electrical static charge.

Thorburn's **TC34** is reinforced with a Dupont Nomex braid and is similar in construction to TC33, except for the PTFE inner core which is white.

FEATURES:

- Available with conductive or non-conductive core
- Ideal dielectric medium pressure superstructure potroom hose

HOSE CONSTRUCTION:

INNER CORE: Convuluted PTFE

REINFORCEMENT: PTFE-impregnated fiberglass and polyester or Nomex nylon braid

TEMPERATURE RANGE: -54°C to 135°C (-65°F to 275°F)

STANDARDS:

Complies with FDA requirements for portable water systems.
Meets National Bureau of Standards conductivity requirements.

| Part Number | Nominal Size | | Nominal I.D. | | Nominal O.D. | | Operating Pressure | | Room Temp. Min. Burst | | Max. Continuous Length | | Min. Bend Radius | | Hose Weight | |
|--------------|--------------|-------|--------------|------|--------------|------|--------------------|-----|-----------------------|-----|------------------------|----|------------------|------|-------------|-------|
| | DN | in | mm | in | mm | in | bar | psi | bar | psi | m | ft | mm | in | kg/m | lb/ft |
| TC33/TC34-8 | 15 | 1/2 | 12.7 | 0.50 | 19.6 | 0.77 | 13.8 | 200 | 51.7 | 750 | 15.2 | 50 | 25.4 | 1.00 | 0.185 | 0.124 |
| TC33/TC34-10 | 18 | 5/8 | 16.0 | 0.63 | 22.1 | 0.87 | 12.1 | 175 | 48.3 | 700 | 9.14 | 30 | 38.1 | 1.50 | 0.202 | 0.136 |
| TC33/TC34-12 | 20 | 3/4 | 19.1 | 0.75 | 25.7 | 1.09 | 12.1 | 175 | 48.3 | 700 | 9.14 | 30 | 50.8 | 2.00 | 0.274 | 0.184 |
| TC33/TC34-16 | 25 | 1 | 25.4 | 1.00 | 33.3 | 1.31 | 12.1 | 175 | 48.3 | 700 | 9.14 | 30 | 76.2 | 3.00 | 0.357 | 0.240 |
| TC33/TC34-20 | 32 | 1 1/4 | 31.8 | 1.25 | 39.1 | 1.56 | 10.3 | 150 | 41.4 | 600 | 9.14 | 30 | 88.9 | 3.50 | 0.399 | 0.268 |
| TC33/TC34-24 | 40 | 1 1/2 | 38.1 | 1.50 | 45.7 | 1.81 | 10.3 | 150 | 41.4 | 600 | 9.14 | 30 | 101.6 | 4.00 | 0.521 | 0.350 |

Available fitting to end joint hose couplings are found on pages 61 to 71

TC60/61 PTFE Hose Assemblies



| TC60 (top) and TC 61 Hose Assemblies |

STANDARDS: FDA Approved, Accepted by the U.S. Coast Guard, PTFE Perfluorocarbon Resins meets FDA 21 CFR 177.1550 Chlorine Institute Pamphlet 6. Appendix A

APPLICATIONS:

- Chemical loading/unloading
- Chlorine transfer
- Ideal for harsh atmospheric conditions that require extreme corrosion resistance on the exterior of the hose
- Severe applications in hostile environments where external corrosion from the presence of strong acids will attack standard stainless steel braid

Thorburn’s TC60 series hose has a heavy double PVDF braid and is designed for use in severe applications where external hostile environments will attack standard SS braid. When the permeated gases eventually mix with the moisture in air, they can create hydrochloric acid that can quickly attack the stainless steel braid reinforcement. PVDF braid is resistant to most chemicals introduced to the external surface of the hose and is ideal for the transfer of chlorinated fluids/gases that may permeate the PTFE liner.

Thorburn’s TC61 has an antistatic conductive carbon black added to the PTFE to dissipate an electrostatic charge in fuel, steam, or high flow-rate applications.

FEATURES:

- Open pitch, helical convolutions for easy cleaning
- Rated for both medium pressure and full vacuum service
- PTFE inner core provides corrosion resistance
- Tighter bend radius compared to smooth bore PTFE style hose
- Easy to flex and will not flatten when bent
- PTFE available with natural (TC60) or conductive (TC61) liner

HOSE CONSTRUCTION:

TC60 Inner Core: Convoluted 100% pure PTFE

TC61 Inner Core: Convoluted 100% pure PTFE. Has precisely controlled amounts of carbon black added to the inner 15% of the PTFE inner core. This homogeneous material provides a continuous conductive path to the metal end fittings.

REINFORCEMENT: PVDF heavy double braid

TEMPERATURE RANGE: -20°C to 204°C (-20°F to 275°F)

| Part Number | Nominal Size | | Nominal I.D. | | Nominal O.D. | | Operating Pressure | | Room Temp. Min. Burst | | Max. Continuous Length | | Min. Bend Radius | | Hose Weight | |
|-------------|--------------|-------|--------------|------|--------------|------|--------------------|-----|-----------------------|------|------------------------|----|------------------|------|-------------|-------|
| | DN | in | mm | in | mm | in | bar | psi | bar | psi | m | ft | mm | in | kg/m | lb/ft |
| TC60/61-8 | 15 | 1/2 | 12.7 | 0.50 | 24.9 | 0.96 | 34.5 | 500 | 172.4 | 2500 | 22.9 | 75 | 50.8 | 2.0 | 0.22 | 0.15 |
| TC60/61-12 | 20 | 3/4 | 19.1 | 0.75 | 31.8 | 1.25 | 34.5 | 500 | 172.4 | 2500 | 15.2 | 50 | 69.9 | 2.5 | 0.37 | 0.25 |
| TC60/61-16 | 25 | 1 | 25.4 | 1.00 | 39.6 | 1.56 | 34.5 | 500 | 172.4 | 2500 | 15.2 | 50 | 101.6 | 6.0 | 0.49 | 0.33 |
| TC60/61-24 | 40 | 1 1/2 | 38.1 | 1.50 | 56.9 | 2.24 | 25.9 | 375 | 129.3 | 1875 | 15.2 | 50 | 152.4 | 10.0 | 0.89 | 0.60 |
| TC60/61-32 | 50 | 2 | 50.8 | 2.00 | 67.8 | 2.67 | 17.2 | 375 | 86.2 | 1875 | 15.2 | 50 | 190.5 | 12.0 | 1.19 | 0.80 |

Available fitting to end joint hose couplings are found on pages 61 to 71

TC50/TC51 PTFE Hose Assemblies



| TC50 (top) and TC51 Hose Assemblies |

APPLICATIONS:

- Pharmaceuticals
- Food transfer
- Rail truck loading/unloading
- Solvents– from acetone to xylene
- Plating chemicals– sodium cyanide, pickling liquors
- Cleaners– alkali solvents, perchlorohydrate, trichloroethylene
- Black liquor, spill clean-up, spent caustic acid

Thorburn’s TC50 is a flexible convoluted bore PTFE hose with high tensile stainless steel braided reinforcement, protected with an added abrasive resistant EPDM cover that is designed for low force small minimum bend radii, long term flex life, and chemically inert for corrosion resistance.

Thorburn’s TC51 has an antistatic conductive carbon black added to the PTFE to dissipate an electrostatic charge in fuel, steam, or high flow-rate applications.

FEATURES:

- PTFE inner liner provides outstanding corrosion resistance
- Requires a minimum amount of force to flex
- Tight bend radius
- Open pitch, helical convolutions for easy cleaning
- Tough EPDM cover provides durability and easy handling
- PTFE available with natural or conductive liner

HOSE CONSTRUCTION:

TC50 INNER CORE: Convoluted 100% pure PTFE

TC51 INNER CORE: Convoluted 100% pure PTFE with a precisely controlled amount of carbon black added to the inner 15% of the PTFE inner core. This homogeneous material provides a continuous conductive path to the metal end fittings.

REINFORCEMENT: A580 type 304 (EN1.4301) high tensile stainless steel braid.

TEMPERATURE RANGE: -54°C to 150°C (-65°F to 302°F)

COVER: Smooth compounded EPDM blend to provide outstanding resistance to abrasion, chemicals and weathering.

| Part Number | Nominal Size | | Nominal I.D. | | Nominal O.D. | | Operating Pressure | | Room Temp. Min. Burst | | Max. Continuous Length | | Min. Bend Radius | | Hose Weight | |
|-------------|--------------|-------|--------------|------|--------------|------|--------------------|------|-----------------------|------|------------------------|----|------------------|------|-------------|-------|
| | DN | in | mm | in | mm | in | bar | psi | bar | psi | m | ft | mm | in | kg/m | lb/ft |
| TC50/51-08 | 15 | 1/2 | 12 | 0.47 | 25 | 0.97 | 96.5 | 1400 | 399.9 | 5800 | 22.9 | 75 | 25.4 | 1.00 | 0.54 | 0.36 |
| TC50/51-12 | 20 | 3/4 | 18 | 0.72 | 32 | 1.25 | 68.9 | 1000 | 275.8 | 4000 | 15.2 | 50 | 50.8 | 2.00 | 0.73 | 0.49 |
| TC50/51-16 | 25 | 1 | 25 | 0.97 | 40 | 1.56 | 68.9 | 1000 | 275.8 | 4000 | 15.2 | 50 | 76.2 | 3.00 | 0.94 | 0.63 |
| TC50/51-24 | 40 | 1 1/2 | 39 | 1.54 | 57 | 2.24 | 51.7 | 750 | 206.8 | 3000 | 15.2 | 50 | 190.5 | 7.50 | 1.55 | 1.04 |
| TC50/51-32 | 50 | 2 | 50 | 1.97 | 68 | 2.67 | 34.5 | 500 | 137.9 | 2000 | 15.2 | 50 | 254.0 | 10.0 | 1.98 | 1.33 |

Available fitting to end joint hose couplings are found on pages 61 to 71

Series “TC” PTFE Hose Couplings

Hex Male Pipe

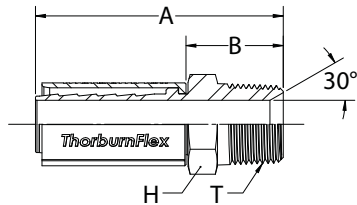

| Part Number | Nominal Hose I.D. | | Fitting Size | | Thread Size | A | | B Cutoff Allowance | | H Hex |
|-------------|-------------------|-----|--------------|-----|--------------|------|-----|--------------------|----|-------|
| | Inch | mm | Inch | mm | | Inch | mm | Inch | mm | Inch |
| TC-04-04MP | 1/4 | 6 | 1/4 | 6 | 1/4-18 | 2.13 | 54 | 0.94 | 24 | 0.56 |
| TC-06-06MP | 3/8 | 10 | 3/8 | 10 | 3/8-18 | 2.25 | 57 | 1.11 | 28 | 0.69 |
| TC-08-08MP | 1/2 | 12 | 1/2 | 12 | 1/2-14 | 2.91 | 74 | 1.48 | 37 | 0.88 |
| TC-12-12MP | 3/4 | 20 | 3/4 | 20 | 3/4-14 | 3.22 | 82 | 1.51 | 38 | 1.13 |
| TC-16-16MP | 1 | 25 | 1 | 25 | 1-11 1/2 | 3.69 | 94 | 1.98 | 50 | 1.38 |
| TC-20-20MP | 1 1/4 | 30 | 1 1/4 | 30 | 1 1/4-11 1/2 | 4.39 | 112 | 2.09 | 53 | 1.75 |
| TC-24-24MP | 1 1/2 | 40 | 1 1/2 | 40 | 1 1/2-11 1/2 | 4.82 | 122 | 2.18 | 55 | 2.00 |
| TC-32-32MP | 2 | 50 | 2 | 50 | 2-11 1/2 | 5.86 | 149 | 2.33 | 59 | 2.50 |
| TC-48-48MP | 3 | 80 | 3 | 80 | 3-8 | 6.50 | 165 | 3.40 | 86 | 3.50 |
| TC-64-64MP | 4 | 100 | 4 | 100 | 4-8 | 7.00 | 178 | 3.63 | 92 | 4.50 |

Materials: 316 Stainless Steel. Material ordering codes are found on Page 76

Female JIC 37° Swivel

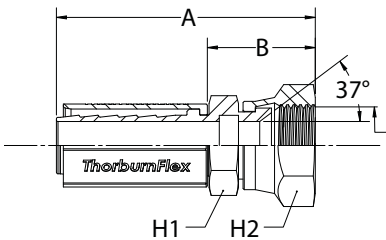

| Part Number | Nominal Hose I.D. | | Fitting Size | | Thread Size | A | | B Cutoff Allowance | | H2 Hex | H1 Hex |
|-------------|-------------------|----|--------------|----|-------------|------|-----|--------------------|----|--------|--------|
| | Inch | mm | Inch | mm | | Inch | mm | Inch | mm | Inch | Inch |
| TC-04-04FJX | 1/4 | 6 | 1/4 | 6 | 7/16-20 | 2.13 | 54 | 1.04 | 26 | 0.33 | 0.56 |
| TC-06-06FJX | 3/8 | 10 | 3/8 | 10 | 9/16-18 | 2.25 | 57 | 1.12 | 28 | 0.75 | 0.75 |
| TC-08-08FJX | 1/2 | 12 | 1/2 | 12 | 3/4-16 | 2.76 | 70 | 1.32 | 34 | 0.69 | 0.88 |
| TC-12-12FJX | 3/4 | 20 | 3/4 | 20 | 1 1/16-12 | 3.39 | 86 | 1.68 | 43 | 1.00 | 1.25 |
| TC-16-16FJX | 1 | 25 | 1 | 25 | 1 5/16-12 | 3.63 | 92 | 1.92 | 49 | 1.25 | 1.50 |
| TC-20-20FJX | 1 1/4 | 30 | 1 1/4 | 30 | 1 5/8-12 | 4.58 | 116 | 2.28 | 58 | 2.00 | 2.00 |
| TC-24-24FJX | 1 1/2 | 40 | 1 1/2 | 40 | 1 7/8-12 | 5.10 | 130 | 2.46 | 63 | 2.25 | 2.25 |
| TC-32-32FJX | 2 | 50 | 2 | 50 | 2 1/2-12 | 6.45 | 164 | 2.92 | 74 | 2.50 | 2.88 |

Materials: 316 Stainless Steel. Material ordering codes are found on Page 76

Series “TC” PTFE Hose Couplings

Female “O”Seal™ Straight

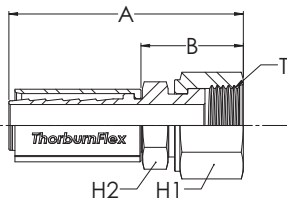

| Part Number | Nominal Hose I.D. | | Fitting Size | | Thread Size | A | | B Cutoff Allowance | | H2 Hex | H1 Hex |
|-------------|-------------------|----|--------------|----|-------------|------|-----|--------------------|----|--------|--------|
| | Inch | mm | Inch | mm | | Inch | mm | Inch | mm | | |
| TC-04-04FOS | 1/4 | 6 | 1/4 | 6 | 9/16-18 | 2.32 | 59 | 1.23 | 31 | 0.50 | 0.69 |
| TC-06-06FOS | 3/8 | 10 | 3/8 | 10 | 11/16-16 | 2.47 | 63 | 1.46 | 37 | 0.63 | 0.81 |
| TC-08-08FOS | 1/2 | 12 | 1/2 | 12 | 13/16-16 | 3.10 | 79 | 1.66 | 42 | 0.94 | 0.94 |
| TC-12-12FOS | 3/4 | 20 | 3/4 | 20 | 1 3/16-12 | 3.56 | 90 | 1.85 | 47 | 1.06 | 1.38 |
| TC-16-16FOS | 1 | 25 | 1 | 25 | 1 7/16-12 | 4.01 | 102 | 2.30 | 58 | 1.38 | 1.63 |
| TC-20-20FOS | 1 1/4 | 30 | 1 1/4 | 30 | 1 11/16-12 | 4.51 | 115 | 2.21 | 56 | 1.75 | 1.88 |
| TC-24-24FOS | 1 1/2 | 40 | 1 1/2 | 40 | 2-12 | 5.80 | 147 | 2.60 | 66 | | |

Materials: 316 Stainless Steel. Material ordering codes are found on Page 76

Butt Weld Tube

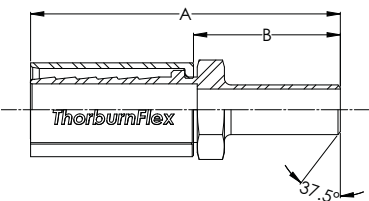

| Part Number | Nominal Hose I.D. | | Tube O.D. | | A | | B Cutoff Allowance | |
|-------------|-------------------|-----|-----------|-----|------|-----|--------------------|-----|
| | Inch | mm | Inch | mm | Inch | mm | Inch | mm |
| TC-08-08BWT | 1/2 | 12 | 1/2 | 12 | 3.75 | 95 | 1.50 | 38 |
| TC-12-12BWT | 3/4 | 20 | 3/4 | 20 | 4.00 | 100 | 1.70 | 43 |
| TC-16-16BWT | 1 | 25 | 1 | 25 | 4.25 | 108 | 1.70 | 43 |
| TC-24-24BWT | 1 1/2 | 40 | 1 1/2 | 40 | 4.50 | 114 | 2.70 | 69 |
| TC-32-32BWT | 2 | 50 | 2 | 50 | 5.00 | 127 | 3.50 | 89 |
| TC-48-48BWT | 3 | 75 | 3 | 75 | 5.75 | 146 | 3.75 | 95 |
| TC-64-64BWT | 4 | 100 | 4 | 100 | 6.00 | 152 | 4.00 | 100 |

Materials: 316 Stainless Steel. Material ordering codes are found on Page 76

Series “TC” PTFE Hose Couplings

Butt Weld Pipe

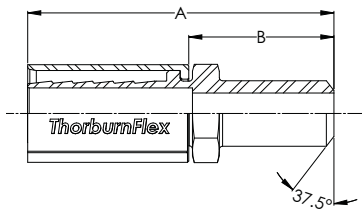

| Part Number | Nominal Hose I.D. | | Pipe O.D. | | A | | B Cutoff Allowance | |
|-------------|-------------------|-----|-----------|-----|------|-----|--------------------|-----|
| | Inch | mm | Inch | mm | Inch | mm | Inch | mm |
| TC-08-08BWP | 1/2 | 12 | 0.9 | 23 | 3.75 | 95 | 1.50 | 38 |
| TC-12-12BWP | 3/4 | 20 | 1.1 | 28 | 4.00 | 100 | 1.70 | 43 |
| TC-16-16BWP | 1 | 25 | 1.3 | 33 | 4.25 | 108 | 1.70 | 43 |
| TC-24-24BWP | 1 1/2 | 40 | 1.9 | 48 | 4.50 | 114 | 2.70 | 69 |
| TC-32-32BWP | 2 | 50 | 2.4 | 61 | 5.00 | 127 | 3.50 | 89 |
| TC-48-48BWP | 3 | 75 | 3.5 | 89 | 5.75 | 146 | 3.75 | 95 |
| TC-64-64BWP | 4 | 100 | 4.5 | 114 | 6.00 | 152 | 4.00 | 100 |

Materials: 316 Stainless Steel. Material ordering codes are found on Page 76

Tube Stub

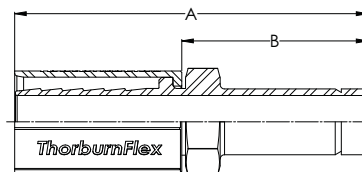

| Part Number | Nominal Hose I.D. | | Tube O.D. | | A | | B Cutoff Allowance | |
|-------------|-------------------|----|-----------|----|------|-----|--------------------|----|
| | Inch | mm | Inch | mm | Inch | mm | Inch | mm |
| TC-04-04T | 1/4 | 6 | 1/4 | 6 | 1.96 | 49 | 0.80 | 20 |
| TC-06-06T | 3/8 | 10 | 3/8 | 10 | 2.42 | 61 | 1.22 | 31 |
| TC-08-08T | 1/2 | 12 | 1/2 | 12 | 2.91 | 74 | 1.44 | 37 |
| TC-12-12T | 3/4 | 20 | 3/4 | 20 | 3.53 | 90 | 1.84 | 47 |
| TC-16-16T | 1 | 25 | 1 | 25 | 3.78 | 96 | 1.94 | 49 |
| TC-24-24T | 1 1/2 | 40 | 1 1/2 | 40 | 5.22 | 133 | 2.53 | 64 |
| TC-32-32T | 2 | 50 | 2 | 50 | 6.82 | 173 | 3.26 | 83 |

Materials: 316 Stainless Steel. Material ordering codes are found on Page 76

Series "TC" PTFE Hose Couplings

Swagelok™ Compatible Tube Fitting With Nut & Ferrule

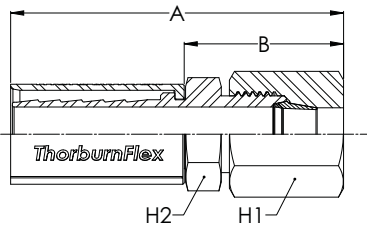

| Part Number | Nominal Hose I.D. | | Tube O.D. | | A | | B Cutoff Allowance | |
|-------------|-------------------|----|-----------|----|------|-----|--------------------|----|
| | Inch | mm | Inch | mm | Inch | mm | Inch | mm |
| TC-04-04TC | 1/4 | 6 | 1/4 | 6 | 2.02 | 51 | 0.82 | 21 |
| TC-06-06TC | 3/8 | 10 | 3/8 | 10 | 2.48 | 63 | 1.28 | 33 |
| TC-08-08TC | 1/2 | 12 | 1/2 | 12 | 2.81 | 71 | 1.34 | 34 |
| TC-12-12TC | 3/4 | 20 | 3/4 | 20 | 3.44 | 87 | 1.75 | 44 |
| TC-16-16TC | 1 | 25 | 1 | 25 | 3.61 | 92 | 1.92 | 49 |
| TC-24-24TC | 1 1/2 | 40 | 1 1/2 | 40 | 5.12 | 130 | 2.43 | 62 |
| TC-32-32TC | 2 | 50 | 2 | 50 | 6.72 | 171 | 3.16 | 80 |

Materials: 316 Stainless Steel. Material ordering codes are found on Page 76
Swagelok™ is a Registered Trademark of Crawford Company

Swivel Flange 150 lbs

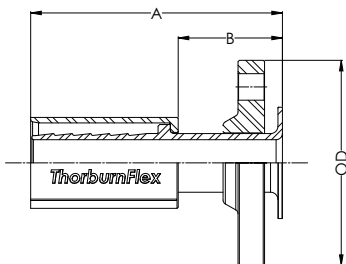

| Part Number | Nominal Hose I.D. | | Nominal Flange Size | | A | | B Cutoff Allowance | | Bolt Circle | | Flange O.D. | |
|---------------|-------------------|-----|---------------------|-----|------|-----|--------------------|----|-------------|-----|-------------|-----|
| | Inch | mm | Inch | mm | Inch | mm | Inch | mm | Inch | mm | Inch | mm |
| TC-08-08FL150 | 1/2 | 12 | 1/2 | 12 | 3.1 | 79 | 1.3 | 33 | 2.4 | 61 | 3.5 | 89 |
| TC-12-12FL150 | 3/4 | 20 | 3/4 | 20 | 3.2 | 81 | 1.4 | 36 | 2.8 | 71 | 3.9 | 99 |
| TC-16-16FL150 | 1 | 25 | 1 | 25 | 3.4 | 86 | 1.5 | 38 | 3.1 | 79 | 4.3 | 109 |
| TC-20-20FL150 | 1 1/4 | 30 | 1 1/4 | 30 | 3.5 | 89 | 1.5 | 38 | 3.5 | 89 | 4.6 | 117 |
| TC-24-24FL150 | 1 1/4 | 40 | 1 1/4 | 40 | 3.7 | 94 | 1.6 | 41 | 3.9 | 99 | 5.0 | 127 |
| TC-32-32FL150 | 2 | 50 | 2 | 50 | 4.1 | 104 | 1.8 | 46 | 4.8 | 122 | 6.0 | 152 |
| TC-48-48FL150 | 3 | 75 | 3 | 75 | 5.6 | 142 | 2.5 | 64 | 6.0 | 152 | 7.5 | 191 |
| TC-64-64FL150 | 4 | 100 | 4 | 100 | 6.2 | 157 | 3 | 76 | 7.5 | 191 | 9.0 | 229 |

Materials: 316 Stainless Steel. Material ordering codes are found on Page 76
Note: Other flange drillings available upon request (ANSI 300lbs, PN10, PN16, PN25).

Series “TC” PTFE Hose Couplings

Swivel Flange PN10/PN16

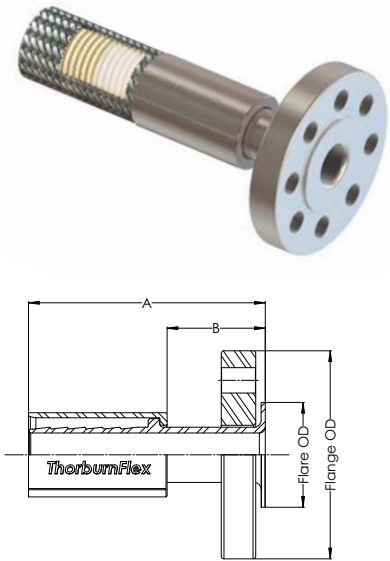

| Part Number | Nominal Flange Size | | A | | B Cutoff Allowance | | Bolt Holes # | Bolt Circle Inch | Stub Flare O.D. | | Flange O.D. | |
|----------------|---------------------|-----|------|-----|--------------------|-----|--------------|------------------|-----------------|-----|-------------|-----|
| | Inch | mm | Inch | mm | Inch | mm | | | Inch | mm | Inch | mm |
| TR40-08-08LFPN | 1/2 | 12 | 2.9 | 74 | 1.40 | 36 | 4 | 2.56 | 1.77 | 45 | 3.74 | 95 |
| TR40-12-12LFPN | 3/4 | 20 | 3.1 | 79 | 1.50 | 38 | 4 | 2.95 | 2.28 | 58 | 4.13 | 105 |
| TR40-16-16LFPN | 1 | 25 | 3.4 | 86 | 1.65 | 42 | 4 | 3.35 | 2.68 | 68 | 4.53 | 115 |
| TR40-20-20LFPN | 1 1/4 | 30 | 3.9 | 99 | 1.68 | 43 | 4 | 3.94 | 3.07 | 78 | 5.51 | 140 |
| TR40-24-24LFPN | 1 1/2 | 40 | 4.0 | 102 | 1.85 | 47 | 4 | 4.33 | 3.46 | 88 | 5.91 | 150 |
| TR40-32-32LFPN | 2 | 50 | 5.7 | 145 | 2.70 | 69 | 4 | 4.92 | 4.02 | 102 | 6.50 | 165 |
| TR40-48-48LFPN | 3 | 75 | 6.0 | 152 | 2.90 | 74 | 8 | 6.30 | 5.43 | 138 | 7.87 | 200 |
| TR40-64-64LFPN | 4 | 100 | 7.0 | 178 | 3.50 | 89 | 8 | 7.09 | 6.22 | 158 | 8.66 | 220 |
| TR40-96-96LFPN | 6 | 150 | 9.0 | 229 | 4.00 | 102 | 8 | 9.45 | 8.35 | 212 | 11.22 | 285 |

Materials: 316 Stainless Steel. Material ordering codes are found on Page 76

Note: Other flange drillings available upon request (ANSI 300lbs, PN10, PN16, PN25).

Tri-Clamp Sanitary Flange

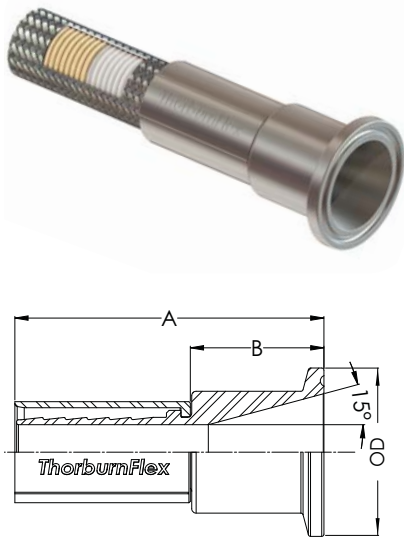

| Part Number | Nominal Hose I.D. | | Nominal Flange Size | | A | | B Cutoff Allowance | | Flange I.D. | | Flange O.D. | |
|-------------|-------------------|-----|---------------------|-----|------|-----|--------------------|----|-------------|----|-------------|-----|
| | Inch | mm | Inch | mm | Inch | mm | Inch | mm | Inch | mm | Inch | mm |
| TC-16-16STC | 1 | 25 | 1 | 25 | 2.70 | 69 | 1.25 | 32 | 0.87 | 22 | 1.98 | 50 |
| TC-24-24STC | 1 1/2 | 40 | 1 1/2 | 40 | 3.04 | 77 | 1.25 | 32 | 1.39 | 35 | 1.98 | 50 |
| TC-32-32STC | 2 | 50 | 2 | 50 | 3.23 | 82 | 1.25 | 32 | 1.87 | 47 | 2.52 | 64 |
| TC-48-48STC | 3 | 75 | 3 | 75 | 4.65 | 118 | 1.25 | 32 | 2.87 | 73 | 3.58 | 91 |
| TC-64-64STC | 4 | 100 | 4 | 100 | 5.09 | 129 | 1.25 | 32 | 3.83 | 97 | 4.68 | 119 |

Materials: 316 Stainless Steel. Material ordering codes are found on Page 76

Series “TC” PTFE Hose Couplings

Mini Sanitary Flange Fitting



| Part Number | Nominal Hose I.D. | | Nominal Flange Size | | A | | B Cutoff Allowance | | Flange I.D. | | Flange O.D. | |
|-------------|-------------------|----|---------------------|----|------|----|--------------------|----|-------------|-----|-------------|----|
| | Inch | mm | Inch | mm | Inch | mm | Inch | mm | Inch | mm | Inch | mm |
| TC-08-08MSC | 1/2 | 12 | 1/2 | 12 | 3.07 | 78 | 1.25 | 32 | 0.38 | 9.7 | 0.98 | 24 |
| TC-12-12MSC | 3/4 | 20 | 3/4 | 20 | 3.19 | 81 | 1.25 | 32 | 0.63 | 16 | 0.98 | 24 |

Materials: 316 Stainless Steel. Material ordering codes are found on Page 76

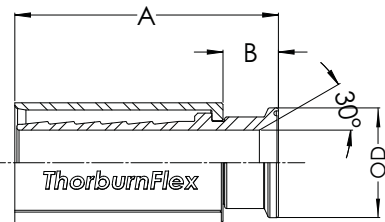

Swivel Flange 150 lbs Encapsulated



| Part Number | Nominal Hose I.D. | | Nominal Flange Size | | A | | B Cutoff Allowance | | Bolt Circle | | Flange O.D. | |
|----------------|-------------------|-----|---------------------|-----|------|-----|--------------------|----|-------------|-----|-------------|-----|
| | Inch | mm | Inch | mm | Inch | mm | Inch | mm | Inch | mm | Inch | mm |
| TC-08-08FL150E | 1/2 | 12 | 1/2 | 12 | 3.1 | 79 | 1.3 | 33 | 2.4 | 61 | 3.5 | 89 |
| TC-12-12FL150E | 3/4 | 20 | 3/4 | 20 | 3.2 | 81 | 1.4 | 36 | 2.8 | 71 | 3.9 | 99 |
| TC-16-16FL150E | 1 | 25 | 1 | 25 | 3.4 | 86 | 1.5 | 38 | 3.1 | 79 | 4.3 | 109 |
| TC-20-20FL150E | 1 1/4 | 30 | 1 1/4 | 30 | 3.5 | 89 | 1.5 | 38 | 3.5 | 89 | 4.6 | 117 |
| TC-24-24FL150E | 1 1/4 | 40 | 1 1/4 | 40 | 3.7 | 94 | 1.6 | 41 | 3.9 | 99 | 5.0 | 127 |
| TC-32-32FL150E | 2 | 50 | 2 | 50 | 4.1 | 104 | 1.8 | 46 | 4.8 | 122 | 6.0 | 152 |
| TC-48-48FL150E | 3 | 75 | 3 | 75 | 5.6 | 142 | 2.5 | 64 | 6 | 152 | 7.5 | 191 |
| TC-64-64FL150E | 4 | 100 | 4 | 100 | 6.2 | 157 | 3 | 76 | 7.5 | 191 | 9 | 229 |

Materials: 316 Stainless Steel. Material ordering codes are found on Page 76

Note: Other flange drillings available upon request (ANSI 300lbs, PN10, PN16, PN25).

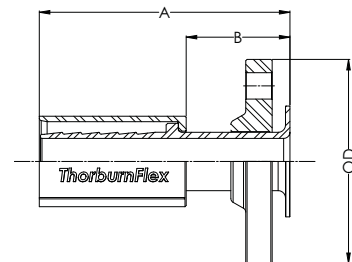

Series “TC” PTFE Hose Couplings

Tri-Clamp Sanitary Flange Encapsulated

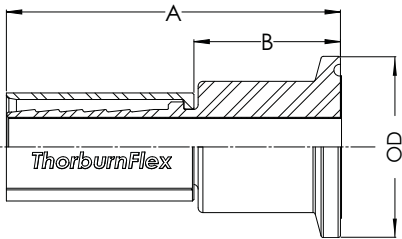

| Part Number | Nominal Hose I.D. | | Nominal Flange Size | | A | | B Cutoff Allowance | | Flange I.D. | | Flange O.D. | |
|--------------|-------------------|-----|---------------------|-----|------|-----|--------------------|----|-------------|----|-------------|-----|
| | Inch | mm | Inch | mm | Inch | mm | Inch | mm | Inch | mm | Inch | mm |
| TC-16-16STCE | 1 | 25 | 1 | 25 | 2.70 | 69 | 1.25 | 32 | 0.87 | 22 | 1.98 | 50 |
| TC-24-24STCE | 1 1/2 | 40 | 1 1/2 | 40 | 3.04 | 77 | 1.25 | 32 | 1.39 | 35 | 1.98 | 50 |
| TC-32-32STCE | 2 | 50 | 2 | 50 | 3.23 | 82 | 1.25 | 32 | 1.87 | 47 | 2.52 | 64 |
| TC-48-48STCE | 3 | 75 | 3 | 75 | 4.65 | 118 | 1.25 | 32 | 2.87 | 73 | 3.58 | 91 |
| TC-64-64STCE | 4 | 100 | 4 | 100 | 5.09 | 129 | 1.25 | 32 | 3.83 | 97 | 4.68 | 119 |

Materials: 316 Stainless Steel. Material ordering codes are found on Page 76

Mini Sanitary Flange Fitting Encapsulated

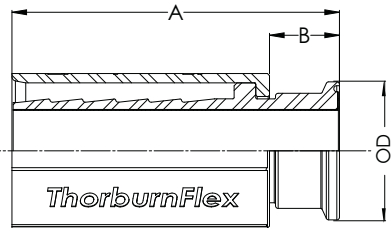

| Part Number | Nominal Hose I.D. | | Nominal Flange Size | | A | | B Cutoff Allowance | | Flange I.D. | | Flange O.D. | |
|--------------|-------------------|----|---------------------|----|------|----|--------------------|----|-------------|-----|-------------|----|
| | Inch | mm | Inch | mm | Inch | mm | Inch | mm | Inch | mm | Inch | mm |
| TC-08-08MSCE | 1/2 | 12 | 1/2 | 12 | 3.07 | 78 | 1.25 | 32 | 0.38 | 9.7 | 0.98 | 24 |
| TC-12-12MSCE | 3/4 | 20 | 3/4 | 20 | 3.19 | 81 | 1.25 | 32 | 0.63 | 16 | 0.98 | 24 |

Materials: 316 Stainless Steel. Material ordering codes are found on Page 76

Series “TC” PTFE Hose Couplings

Female “Type C” Cam & Groove Couplings

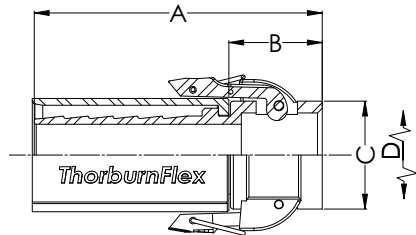

| Part Number | Nominal Hose I.D. | | Fitting Size | | A | | B Cutoff Allowance | | C O.D. | | D Ext. Cam Arms | |
|-------------|-------------------|-----|--------------|-----|------|-----|--------------------|-----|--------|-----|-----------------|-----|
| | Inch | mm | Inch | mm | Inch | mm | Inch | mm | Inch | mm | Inch | mm |
| TC-08-08C | 1/2 | 12 | 1/2 | 12 | 4.00 | 100 | 2.50 | 64 | 2.11 | 54 | 4.51 | 115 |
| TC-12-12C | 3/4 | 20 | 3/4 | 20 | 4.25 | 108 | 2.50 | 64 | 2.11 | 54 | 4.51 | 115 |
| TC-16-16C | 1 | 25 | 1 | 25 | 4.75 | 121 | 3.00 | 75 | 2.44 | 62 | 5.10 | 130 |
| TC-24-24C | 1 1/2 | 40 | 1 1/2 | 40 | 6.25 | 159 | 3.50 | 89 | 3.56 | 90 | 7.16 | 182 |
| TC-32-32C | 2 | 50 | 2 | 50 | 7.50 | 191 | 4.00 | 100 | 3.94 | 100 | 7.54 | 192 |
| TC-48-48C | 3 | 75 | 3 | 75 | 8.00 | 202 | 4.50 | 114 | 5.46 | 139 | 9.56 | 243 |
| TC-64-64C | 4 | 100 | 4 | 100 | 8.25 | 210 | 4.75 | 121 | 6.56 | 167 | 10.56 | 271 |

Materials: 316 Stainless Steel. Material ordering codes are found on Page 76

Male “Type E” Cam & Groove Couplings

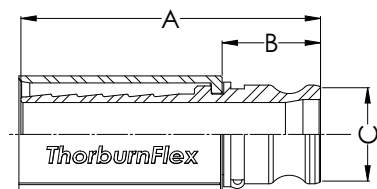

| Part Number | Nominal Hose I.D. | | Fitting Size | | A | | B Cutoff Allowance | | C O.D. | |
|-------------|-------------------|-----|--------------|-----|------|-----|--------------------|-----|--------|-----|
| | Inch | mm | Inch | mm | Inch | mm | Inch | mm | Inch | mm |
| TC-08-08E | 1/2 | 12 | 1/2 | 12 | 4.50 | 114 | 3.00 | 75 | 1.26 | 32 |
| TC-12-12E | 3/4 | 20 | 3/4 | 20 | 4.75 | 121 | 3.00 | 75 | 1.26 | 32 |
| TC-16-16E | 1 | 25 | 1 | 25 | 5.25 | 133 | 3.50 | 89 | 1.63 | 41 |
| TC-24-24E | 1 1/2 | 40 | 1 1/2 | 40 | 6.75 | 171 | 4.00 | 100 | 2.14 | 54 |
| TC-32-32E | 2 | 50 | 2 | 50 | 8.03 | 204 | 4.50 | 114 | 2.64 | 67 |
| TC-48-48E | 3 | 75 | 3 | 75 | 8.75 | 222 | 5.25 | 133 | 3.70 | 94 |
| TC-64-64E | 4 | 100 | 4 | 100 | 9.00 | 229 | 5.50 | 140 | 4.71 | 120 |

Materials: 316 Stainless Steel. Material ordering codes are found on Page 76

Series “TC” PTFE Hose Couplings

Female “Type C” Cam & Groove Encapsulated Couplings

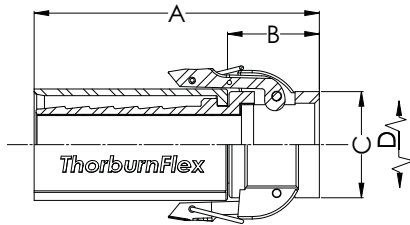

| Part Number | Nominal Hose I.D. | | Fitting Size | | A | | B Cutoff Allowance | | C O.D. | | D Ext. Cam Arms | |
|-------------|-------------------|-----|--------------|-----|------|-----|--------------------|-----|--------|-----|-----------------|-----|
| | Inch | mm | Inch | mm | Inch | mm | Inch | mm | Inch | mm | Inch | mm |
| TC-08-08CE | 1/2 | 12 | 1/2 | 12 | 4.00 | 100 | 2.50 | 64 | 2.11 | 54 | 4.51 | 115 |
| TC-12-12CE | 3/4 | 20 | 3/4 | 20 | 4.25 | 108 | 2.50 | 64 | 2.11 | 54 | 4.51 | 115 |
| TC-16-16CE | 1 | 25 | 1 | 25 | 4.75 | 121 | 3.00 | 75 | 2.44 | 62 | 5.10 | 130 |
| TC-24-24CE | 1 1/2 | 40 | 1 1/2 | 40 | 6.25 | 159 | 3.50 | 89 | 3.56 | 90 | 7.16 | 182 |
| TC-32-32CE | 2 | 50 | 2 | 50 | 7.50 | 191 | 4.00 | 100 | 3.94 | 100 | 7.54 | 192 |
| TC-48-48CE | 3 | 75 | 3 | 75 | 8.00 | 202 | 4.50 | 114 | 5.46 | 139 | 9.56 | 243 |
| TC-64-64CE | 4 | 100 | 4 | 100 | 8.25 | 210 | 4.75 | 121 | 6.56 | 167 | 10.56 | 271 |

Materials: 316 Stainless Steel insert encapsulated with PTFE. Material ordering codes are found on Page 76

Male “Type E” Cam & Groove Encapsulated Couplings

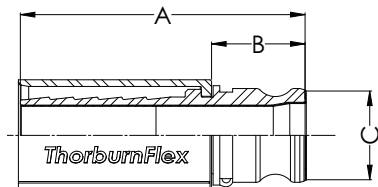

| Part Number | Nominal Hose I.D. | | Fitting Size | | A | | B Cutoff Allowance | | C O.D. | |
|-------------|-------------------|-----|--------------|-----|------|-----|--------------------|-----|--------|-----|
| | Inch | mm | Inch | mm | Inch | mm | Inch | mm | Inch | mm |
| TC-08-08EE | 1/2 | 12 | 1/2 | 12 | 4.50 | 114 | 3.00 | 75 | 1.26 | 32 |
| TC-12-12EE | 3/4 | 20 | 3/4 | 20 | 4.75 | 121 | 3.00 | 75 | 1.26 | 32 |
| TC-16-16EE | 1 | 25 | 1 | 25 | 5.25 | 133 | 3.50 | 89 | 1.63 | 41 |
| TC-24-24EE | 1 1/2 | 40 | 1 1/2 | 40 | 6.75 | 171 | 4.00 | 100 | 2.14 | 54 |
| TC-32-32EE | 2 | 50 | 2 | 50 | 8.03 | 204 | 4.50 | 114 | 2.64 | 67 |
| TC-48-48EE | 3 | 75 | 3 | 75 | 8.75 | 222 | 5.25 | 133 | 3.70 | 94 |
| TC-64-64EE | 4 | 100 | 4 | 100 | 9.00 | 229 | 5.50 | 140 | 4.71 | 120 |

Materials: 316 Stainless Steel insert encapsulated with PTFE. Material ordering codes are found on Page 76

Series “TC” PTFE Hose Couplings

Female “Type C” Cam & Groove Polypropylene Couplings

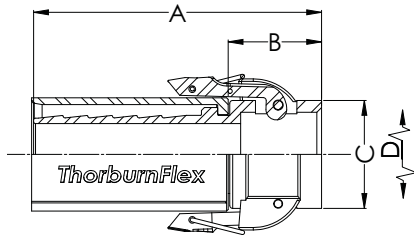

| Part Number | Nominal Hose I.D. | | Fitting Size | | A | | B Cutoff Allowance | | C O.D. | | D Ext. Cam Arms | |
|-------------|-------------------|-----|--------------|-----|------|-----|--------------------|-----|--------|-----|-----------------|-----|
| | Inch | mm | Inch | mm | Inch | mm | Inch | mm | Inch | mm | Inch | mm |
| TC-08-08CP | 1/2 | 12 | 1/2 | 12 | 4.00 | 100 | 2.50 | 64 | 2.11 | 54 | 4.51 | 115 |
| TC-12-12CP | 3/4 | 20 | 3/4 | 20 | 4.25 | 108 | 2.50 | 64 | 2.11 | 54 | 4.51 | 115 |
| TC-16-16CP | 1 | 25 | 1 | 25 | 4.75 | 121 | 3.00 | 75 | 2.44 | 62 | 5.10 | 130 |
| TC-24-24CP | 1 1/2 | 40 | 1 1/2 | 40 | 6.25 | 159 | 3.50 | 89 | 3.56 | 90 | 7.16 | 182 |
| TC-32-32CP | 2 | 50 | 2 | 50 | 7.50 | 191 | 4.00 | 100 | 3.94 | 100 | 7.54 | 192 |
| TC-48-48CP | 3 | 75 | 3 | 75 | 8.00 | 202 | 4.50 | 114 | 5.46 | 139 | 9.56 | 243 |
| TC-64-64CP | 4 | 100 | 4 | 100 | 8.25 | 210 | 4.75 | 121 | 6.56 | 167 | 10.56 | 271 |

Materials: 316 Stainless Steel Ferrule with Polypropylene insert. Material ordering codes are found on Page 76
 Maximum Pressure: 90 PSI - 3/4" (20 mm) to 2" (50 mm) | 50 PSI - 3" (75 mm) to 4" (100 mm)
 Maximum Temperature: 60°C (140°F)

Male “Type E” Cam & Groove Polypropylene Couplings

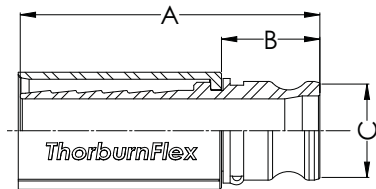

| Part Number | Nominal Hose I.D. | | Fitting Size | | A | | B Cutoff Allowance | | C O.D. | |
|-------------|-------------------|-----|--------------|-----|------|-----|--------------------|-----|--------|-----|
| | Inch | mm | Inch | mm | Inch | mm | Inch | mm | Inch | mm |
| TC-08-08EP | 1/2 | 12 | 1/2 | 12 | 4.50 | 114 | 3.00 | 75 | 1.26 | 32 |
| TC-12-12EP | 3/4 | 20 | 3/4 | 20 | 4.75 | 121 | 3.00 | 75 | 1.26 | 32 |
| TC-16-16EP | 1 | 25 | 1 | 25 | 5.25 | 133 | 3.50 | 89 | 1.63 | 41 |
| TC-24-24EP | 1 1/2 | 40 | 1 1/2 | 40 | 6.75 | 171 | 4.00 | 100 | 2.14 | 54 |
| TC-32-32EP | 2 | 50 | 2 | 50 | 8.03 | 204 | 4.50 | 114 | 2.64 | 67 |
| TC-48-48EP | 3 | 75 | 3 | 75 | 8.75 | 222 | 5.25 | 133 | 3.70 | 94 |
| TC-64-64EP | 4 | 100 | 4 | 100 | 9.00 | 229 | 5.50 | 140 | 4.71 | 120 |

Materials: 316 Stainless Steel Ferrule with Polypropylene insert. Material ordering codes are found on Page 76
 Maximum Pressure: 90 PSI - 3/4" (20 mm) to 2" (50 mm) | 50 PSI - 3" (75 mm) to 4" (100 mm)
 Maximum Temperature: 60°C (140°F)

Series “TC” PTFE Hose Couplings

Polypropylene Hex Male Pipe



| Part Number | Nominal Hose I.D. | | Fitting Size | | Thread Size | A | | B Cutoff Allowance | | H Hex |
|-------------|-------------------|----|--------------|----|--------------|------|----|--------------------|----|-------|
| | Inch | mm | Inch | mm | | Inch | mm | Inch | mm | |
| TC-12-12MPP | 3/4 | 20 | 3/4 | 20 | 3/4-14 | 3.00 | 75 | 1.62 | 41 | 1.13 |
| TC-16-16MPP | 1 | 25 | 1 | 25 | 1-11 1/2 | 3.27 | 83 | 1.72 | 44 | 1.38 |
| TC-24-24MPP | 1 1/2 | 40 | 1 1/2 | 40 | 1 1/2-11 1/2 | 3.58 | 91 | 2.07 | 53 | 2.00 |
| TC-32-32MPP | 2 | 50 | 2 | 50 | 2-11 1/2 | 3.93 | 99 | 2.23 | 57 | 2.50 |

Materials: 316 Stainless Steel Ferrule with Polypropylene insert. Material ordering codes are found on Page 76
 Maximum Pressure: 90 PSI - 3/4" (20 mm) to 2" (50 mm) | 50 PSI - 3" (75 mm) to 4" (100 mm)
 Maximum Temperature: 60°C (140°F)

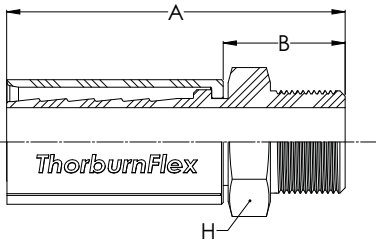

Polypropylene Tri-Clamp Sanitary Flange



| Part Number | Nominal Hose I.D. | | Nominal Flange Size | | A | | B Cutoff Allowance | | Flange I.D. | | Flange O.D. | |
|--------------|-------------------|----|---------------------|----|------|----|--------------------|----|-------------|----|-------------|----|
| | Inch | mm | Inch | mm | Inch | mm | Inch | mm | Inch | mm | Inch | mm |
| TC-16-16STCP | 1 | 25 | 1 | 25 | 2.70 | 69 | 1.25 | 32 | 0.87 | 22 | 1.98 | 50 |
| TC-24-24STCP | 1 1/2 | 40 | 1 1/2 | 40 | 3.04 | 77 | 1.25 | 32 | 1.39 | 35 | 1.98 | 50 |
| TC-32-32STCP | 2 | 50 | 2 | 50 | 3.23 | 82 | 1.25 | 32 | 1.87 | 47 | 2.52 | 64 |

Materials: 316 Stainless Steel Ferrule with Polypropylene insert. Material ordering codes are found on Page 76
 Maximum Pressure: 90 PSI - 3/4" (20 mm) to 2" (50 mm) | 50 PSI - 3" (75 mm) to 4" (100 mm)
 Maximum Temperature: 60°C (140°F)

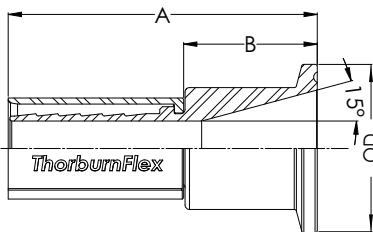

FJ72 Fry-Sil Fire Jacket & FJ73 Fry-Sil Tape



Thorburn's FJ72 Fry-Sil fire Jacket is made from woven fiberglass insulation and 100% iron oxide silicone rubber. The sleeve can withstand continuous exposure to 500° F (260°C); up to 2000°F (1090°C) for 15-20 minutes; and up to 3000°F (1650°C) for 15-30 seconds. Thorburn's FJ72 Fry-Sil fire jackets slip on easily and expands over fittings and connectors.

Features

- Oil and water resistant
- Can be shaped to fit the tightest bends
- Perfect for insulating oil & fuel lines
- Protects against dirt and grime
- Withstands up to 1650°C ambient heat
- Withstands up to 260°C continuous heat

Low cost protection against production interruptions & personal injuries

- Withstands intermittent flame
- Protects against molten spatter
- Prevents slag and resin build up
- Protects against abrasion and corrosion
- Protects operators from hot metal hoses and pipes
- "Danger Red" color provides a strong visual warning
- Skin and respirator irritations caused by fiberglass are minimized by the red silicone rubber cover



| Size Code | Inside Dia (mm) | Inside Dia (Inch) |
|-----------|-----------------|-------------------|
| 04 | 6 | 1/4 |
| 05 | 8 | 5/16 |
| 06 | 10 | 3/8 |
| 07 | 11 | 7/16 |
| 08 | 13 | 1/2 |
| 10 | 16 | 5/8 |
| 12 | 19 | 3/4 |
| 14 | 22 | 7/8 |
| 16 | 25 | 1 |
| 18 | 29 | 1 1/8 |
| 20 | 32 | 1 1/4 |
| 22 | 35 | 1 3/8 |
| 24 | 38 | 1 1/2 |
| 25 | 40 | 1 3/5 |
| 26 | 41 | 1 5/8 |
| 28 | 45 | 1 3/4 |
| 30 | 48 | 1 7/8 |
| 32 | 51 | 2 |

| Size Code | Inside Dia (mm) | Inside Dia (Inch) |
|-----------|-----------------|-------------------|
| 35 | 55 | 2 1/5 |
| 36 | 57 | 2 1/4 |
| 38 | 60 | 2 3/8 |
| 40 | 64 | 2 1/2 |
| 43 | 65 | 2 3/5 |
| 44 | 70 | 2 3/4 |
| 48 | 76 | 3 |
| 50 | 80 | 3 1/5 |
| 52 | 83 | 3 1/4 |
| 54 | 85 | 3 3/8 |
| 56 | 89 | 3 1/2 |
| 57 | 90 | 3 9/16 |
| 60 | 95 | 3 3/4 |
| 64 | 102 | 4 |
| 70 | 110 | 4 1/3 |
| 72 | 114 | 4 1/2 |
| 77 | 120 | 4 4/5 |
| 80 | 127 | 5 |

FJ73 Fry-Sil Tape



Thorburn's FJ73 Fry-Sil Fire Tape is used in situations where Thorburn's FJ72 Fry-Sil Fire Jacket cannot be installed such as when industrial hoses, wires and cables cannot be disconnected. Thorburn's FJ73 Fry-Sil Fire Tape protects industrial hydraulic hose, wires, cables, tube and pipe from exposure to extreme heat conditions. The silicone rubber material protects against molten metals, slag, welding splatter, electrical or grinding sparks and contamination.

How To Order FJ72 Fry-Sil Jacket

| Model | Size (in) | Length (ft) |
|-------|--|--|
| FJ72 | 16 | 25 |
| | 01=1/16 02=1/8 04=1/4 06=3/8 08=1/2 12=3/4 etc. | * Metric length - insert length in millimeters and add suffix "mm" after number. Example: FJ72-16-7620mm |

How To Order FJ73 Fry-Sil Tape

| Model | Size (in) | Length (ft) |
|-------|---|--|
| FJ73 | 16 | 25 |
| | Widths Available Code 16 = 1" (25mm) Code 32 = 2" (50mm) Code 48 = 3" (80mm) | * Metric length - insert length in millimeters and add suffix "mm" after number. Example: FJ72-16-7620mm |

AF Series - Ball Joint Armor-Flex™ Hose Guard

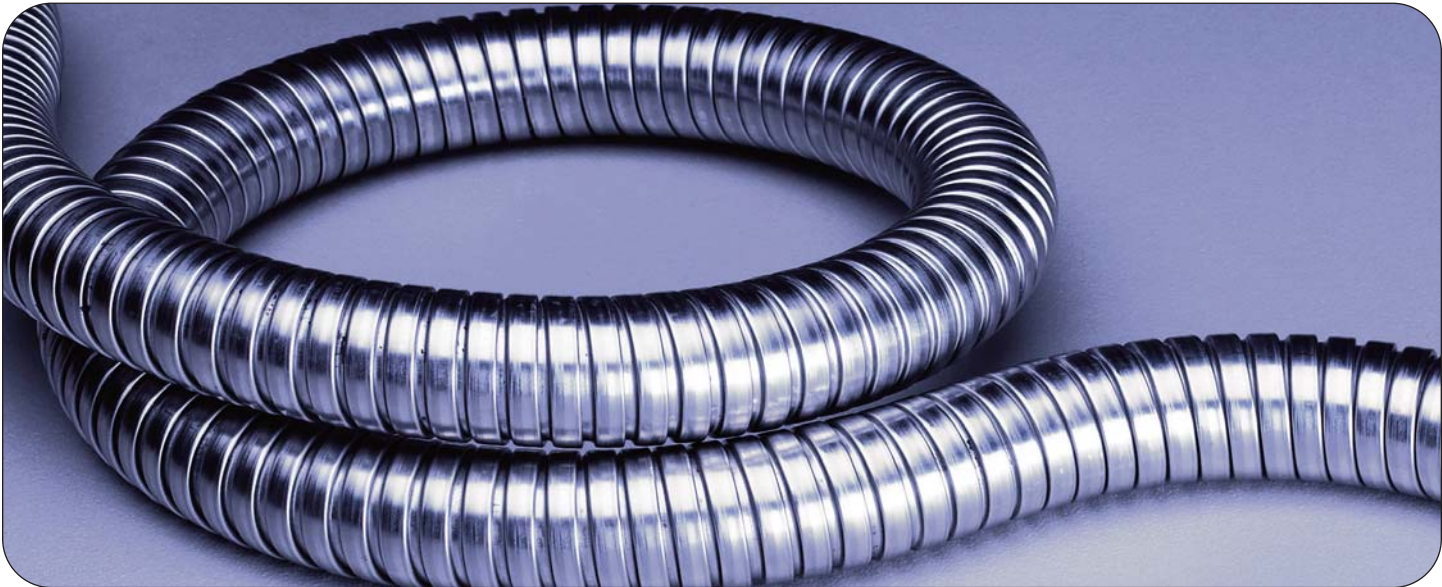

Thorburn's Armor-Flex™ Hose Guard (Cover) will not restrict bending

Thorburn's Ball Joint Armor-Flex™ is different than standard interlock hose in that there is no interlocking parts to restrict hose bending. Armour-Flex is made from concave and convex sections that roll off each other when the hose is bending. It can be used as an outer shield for both metallic and elastomeric hoses. Combined with insulation, Armor-Flex™ can operate in environments up to 1100°C and provides protection against molten splash and abrasion.

Advantages

- Will not restrict bending
- Unlimited flex life and kink resistant
- Minimum force to flex
- Available in steel and stainless steel

Material Codes: AF = Carbon Steel
AFS4 = 304SS
AFS6 = 316SS



Thorburn's Ball Joint Armor-Flex™ tested at 1100°C

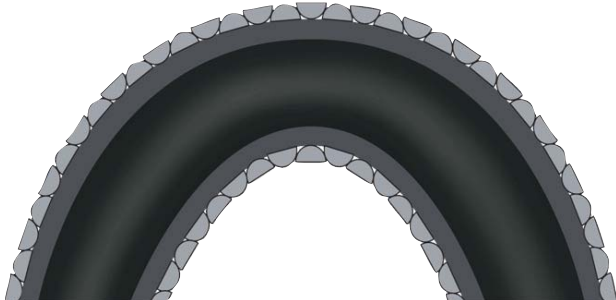

No interlocking parts to restrict bending

LS Series - Lock Section



LS Series (Unpacked)

Thorburn's "LS" series is an "S" lock section hose that is primarily designed for conveying air, exhaust and dry bulk products. A single interlocking strip of metal is spirally wound to form a durable, standard bore flexible hose.

LS Series (Packed)

Thorburn's "LS" series hose can be supplied packed consisting of a continuous strand inserted into the groove of the hose during manufacturing. The strand is sealed inside the hose for additional leak proofing and will not contaminate the media during transfer.

Applications

- Engine exhaust
- Auto heating tubing
- Dust collecting
- Ventilation ducts
- Hot air ducting
- Conveying grain or sawdust
- Fume extracting
- Protective casing

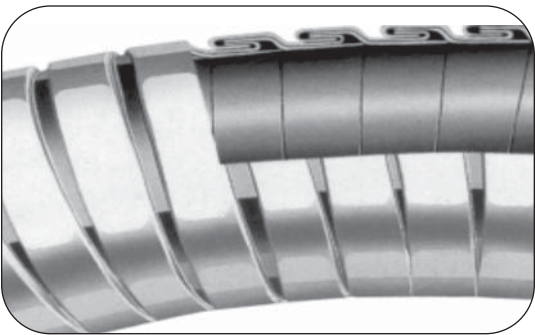

| Packing Type | Benefits | Temperature Ability |
|---------------------------|----------------------------------|---------------------|
| Cotton | Lowest cost | 180°F |
| Pyro-Pak | Coated high temperature filament | 1000°F |
| Hard Packing (Copper, SS) | For extreme high temperatures | 1200°F |
| Elastomeric | Max. pressure/ vacuum resistance | 180°F |

LS Series Part Numbers

| Thickness | Unpacked | Elastomeric Packed | Pyro-Pak Packed | Cotton Packed | Copper Wire Stainless | |
|--------------------------------------|----------|--------------------|-----------------|---------------|-----------------------|-------------|
| | | | | | Packed | Wire Packed |
| Light Weight (0.10" - 0.12") | LS12 | LS12E | LS12A | LS12B | LS12C | LS12S |
| Medium Weight (0.13" - 0.16") | LS16 | LS16E | LS16A | LS16B | LS16C | LS16S |
| Medium-Heavy Weight (0.17" - 0.20") | LS20 | LS20E | LS20A | LS20B | LS20C | LS20S |
| Heavy Weight (0.21" - 0.22") | LS24 | LS24E | LS24A | LS24B | LS24C | LS24S |
| Extreme Heavy Weight (0.23" - 0.30") | LS32 | LS32E | LS32A | LS32B | LS32C | LS32S |

LS Series - Lock Section

| Size | ID (in) | OD (in) | | | | | Minimum Inside Bend Radius (in) | | | | | Approximate Weight (lbs/ft) | | | | |
|------|---------|---------|---------|--------|---------|---------|---------------------------------|------|------|------|------|-----------------------------|------|------|-------|-------|
| | | LS12 | LS16 | LS20 | LS24 | LS32 | LS12 | LS16 | LS20 | LS24 | LS32 | LS12 | LS16 | LS20 | LS24 | LS32 |
| 08 | 1/2 | 5/8 | 11/16 | | | | 3.5 | 4.0 | | | | 0.14 | 0.16 | | | |
| 10 | 5/8 | 3/4 | 13/16 | | | | 4.0 | 4.5 | | | | 0.17 | 0.22 | | | |
| 12 | 3/4 | 7/8 | 15/16 | | | | 4.5 | 5.0 | | | | 0.20 | 0.26 | | | |
| 14 | 7/8 | 1 | 1 1/16 | | | | 5.5 | 6.0 | | | | 0.25 | 0.33 | | | |
| 16 | 1 | 1 1/8 | 1 3/16 | 1 1/4 | | | 6.5 | 7.0 | 7.5 | | | 0.26 | 0.35 | 0.50 | | |
| 18 | 1 1/8 | 1 1/4 | 1 5/16 | 1 3/8 | | | 7.0 | 7.5 | 8.0 | | | 0.30 | 0.39 | 0.60 | | |
| 20 | 1 1/4 | 1 3/8 | 1 7/16 | 1 1/2 | | | 7.5 | 8.5 | 9.0 | | | 0.32 | 0.42 | 0.64 | | |
| 22 | 1 3/8 | 1 1/2 | 1 9/16 | 1 5/8 | | | 8.0 | 9.0 | 10.0 | | | 0.36 | 0.47 | 0.70 | | |
| 24 | 1 1/2 | 1 5/8 | 1 11/16 | 1 3/4 | | | 8.5 | 10.0 | 11.0 | | | 0.40 | 0.52 | 0.85 | | |
| 28 | 1 3/4 | 1 7/8 | 1 15/16 | 2 | | | 10.0 | 11.0 | 11.5 | | | 0.45 | 0.66 | 0.95 | | |
| 32 | 2 | 2 1/8 | 2 3/16 | 2 1/4 | 2 9/32 | 2 5/16 | 11.5 | 12.5 | 13.0 | 15.0 | 17.0 | 0.66 | 0.78 | 1.15 | 1.45 | 1.71 |
| 36 | 2 1/4 | 2 3/8 | 2 7/16 | 2 1/2 | 2 17/32 | 2 9/16 | 13.0 | 14.0 | 15.0 | 17.0 | 18.0 | 0.70 | 0.91 | 1.29 | 1.63 | 1.92 |
| 40 | 2 1/2 | 2 5/8 | 2 11/16 | 2 3/4 | 2 25/32 | 2 13/16 | 15.0 | 16.0 | 17.0 | 19.5 | 20.0 | 0.80 | 1.04 | 1.44 | 1.81 | 2.14 |
| 44 | 2 3/4 | 2 7/8 | 2 15/16 | 3 | 3 1/32 | 3 1/16 | 17.0 | 18.0 | 19.0 | 22.0 | 23.0 | 0.92 | 1.12 | 1.58 | 1.99 | 2.35 |
| 48 | 3 | 3 1/8 | 3 3/16 | 3 1/4 | 3 9/32 | 3 5/16 | 19.0 | 19.5 | 21.0 | 24.0 | 26.0 | 1.02 | 1.33 | 1.73 | 2.18 | 2.56 |
| 56 | 3 1/2 | 3 5/8 | 3 11/16 | 3 3/4 | 3 25/32 | 3 13/16 | 22.0 | 23.5 | 25.0 | 26.0 | 27.0 | 1.26 | 1.64 | 2.01 | 2.54 | 2.99 |
| 64 | 4 | 4 1/8 | 4 3/16 | 4 1/4 | 4 9/32 | 4 5/16 | 24.0 | 25.5 | 27.0 | 28.5 | 30.0 | 1.38 | 1.80 | 2.30 | 2.90 | 3.42 |
| 72 | 4 1/2 | 4 5/8 | 4 11/16 | 4 3/4 | 4 25/32 | 4 13/16 | 27.0 | 28.5 | 30.0 | 31.0 | 33.0 | 1.55 | 2.02 | 2.59 | 3.26 | 3.85 |
| 80 | 5 | 5 1/8 | 5 3/16 | 5 1/4 | 5 9/32 | 5 5/16 | 29.0 | 31.0 | 33.0 | 34.0 | 36.0 | 1.70 | 2.21 | 2.86 | 3.63 | 4.28 |
| 96 | 6 | 6 1/8 | 6 3/16 | 6 1/4 | 6 5/32 | 6 5/16 | 38.0 | 40.5 | 43.0 | 45.0 | 47.0 | 2.00 | 2.60 | 3.45 | 4.35 | 5.13 |
| 112 | 7 | 7 1/8 | 7 3/16 | 7 1/4 | 7 9/32 | 7 5/16 | 45.0 | 46.0 | 48.0 | 50.0 | 52.0 | 2.30 | 3.00 | 4.03 | 5.08 | 5.99 |
| 128 | 8 | 8 1/8 | 8 3/16 | 8 1/4 | 8 9/32 | 8 5/16 | 48.0 | 51.0 | 55.0 | 57.0 | 59.0 | 2.60 | 3.38 | 4.60 | 5.80 | 6.84 |
| 144 | 9 | 9 1/8 | 9 3/16 | 9 1/4 | 9 9/32 | 9 5/16 | 52.0 | 56.0 | 59.0 | 61.0 | 63.0 | 3.10 | 4.03 | 5.18 | 6.53 | 7.70 |
| 160 | 10 | 10 1/8 | 10 3/16 | 10 1/4 | 10 9/32 | 10 5/16 | 56.0 | 60.0 | 63.0 | 66.0 | 69.0 | 3.50 | 4.35 | 5.75 | 7.25 | 8.55 |
| 192 | 12 | | 12 3/16 | 12 1/4 | 12 9/32 | 12 5/16 | | 70.0 | 75.0 | 78.0 | 80.0 | | 5.46 | 6.90 | 8.70 | 10.25 |
| 224 | 14 | | | 14 1/4 | 14 9/32 | 14 5/16 | | | 85.0 | 88.0 | 95.0 | | | 6.05 | 10.15 | 11.95 |

How to Order PTFE Hose Assemblies

| Hose Type | 1st End Type | 1st End Material | 2nd End Type | 2nd End Material | Hose Size | Length in Inches | Cover | | | | | | | | | | | | | | | | | | | | | | | | | | | | | | | | | | | | | | | | | | | | | | | | | | | | | | |
|--|--|--|--------------|---|-----------|------------------|-----------|----|----|-----|----|----|------|----|----|-----|----|----|-----|----|----|-----|----|----|-----|----|----|---|----|----|-------|----|----|-------|----|----|---|----|----|-------|----|----|---|----|----|---|-----|----|---|-----|-----|---|-----|-----|----|-----|-----|----|-----|---|---|
| TS11 | 06 | S6 | 06 | S6 | 32 | 64 | TS | | | | | | | | | | | | | | | | | | | | | | | | | | | | | | | | | | | | | | | | | | | | | | | | | | | | | | |
| <p>Smooth Bore PTFE Hose</p> <p>TS11 TS12 TSX16 TSX17 TSX18 TSX19 TR40 TR41</p> <p>Convuluted Bore PTFE Hose</p> <p>TC29 TC30 TC31 TC32 TC33 TC34 TC50 TC51 TC60 TC61 TC72 TC76 TC85 TC87 TC92 TC96 TC97 TC98</p> | <p>Male Fitting To End Joints</p> <p>01- Male Pipe NPT Rigid 02- Male JIC 37° Rigid 21- Male Inverted Swivel-Straight 22- Male Inverted Swivel 45° Elbow 23- Male Inverted Swivel 90° Elbow</p> <p>Female Swivel Couplings</p> <p>03- Female JIC 37° Swivel 04- Female JIC 37° Swivel 45° Elbow 05- Female JIC 37° Swivel 90° Elbow 06- Female JIC 37° Swivel 90° Long Elbow 07- Female Pipe Swivel 08- Female "O"Seal™ Straight 09- Female "O"Seal™ Swivel 45° Elbow 10- Female "O"Seal™ Swivel 90° Elbow 11- Female "O"Seal™ Swivel 90° Elbow Long Drop 12- Female SAE 45° Swivel 13- Female SAE 45° Swivel 45° Elbow 14- Female SAE 45° Swivel 90° Elbow</p> <p>British Thread Types</p> <p>19- Female BSPP Swivel 20- Female BSPP Swivel 90° Elbow 31- Male BSPP Rigid 32- Male Tapered BSPT</p> <p>Japanese Thread Types</p> <p>33- Female JIS Swivel</p> <p>Welded Fitting To End Joints</p> <p>39- Butt Weld Tube 40- Butt Weld Pipe</p> <p>Instrumentation</p> <p>15- Compression Fitting Swagelok™ Compatible Nut & Ferrule 16- Tube Stub Fitting 17- Male VS 18- Female VS</p> <p>DIN Fitting To End Joints</p> <p>34- Male DIN Light Series 36- Male DIN Heavy Series 35- Female DIN Swivel Straight Light Universal Series 24°/60° Inverted Cone 37- Female DIN Swivel Straight Heavy Series 24° Inverted Cone</p> <p>Camlock Fitting To End Joints</p> <p>28- Male "Type E" Cam & Groove Couplings 27- Female "Type C" Cam & Groove Couplings</p> <p>Flange Fitting To End Joints</p> <p>43- Swivel Flange 150 lbs 44- Swivel Flange 300 lbs 45- Swivel Flange PN10 46- Swivel Flange PN16 47- Swivel Flange PN25</p> <p>Swivel Unions</p> <p>56- Male NPT Union 57- Female NPT Union</p> | <p>Materials</p> <p>AA - All Aluminum BB - All Brass BC - Brass Insert & Aluminum Ferrule CC - All Carbon Steel CA - Carbon Steel Insert & Aluminum Ferrule HH - Hastelloy Insert & Hastelloy Ferrule HS - Hastelloy Insert & 316SS Ferrule II - Inconel 625 Insert & Inconel 625 Ferrule IS - Inconel 625 Insert & 316SS Ferrule KS - Kynar (PVDF) Insert & 316SS Ferrule PS - Polypropolene Insert & 316SS Ferrule SE - All 316SS & Encapsulated PTFE/PFA Insert - All wetted parts PTFE/PFA SF - All 316SS & Flare Through PTFE/PFA Insert - All wetted parts PTFE/PFA S6 - All 316 Stainless Steel SC - 316 Stainless Steel Insert & Carbon Steel Ferrule WW - Specify end type and material VV - Specify end type and material</p> <table border="1"> <thead> <tr> <th>Code</th> <th>in</th> <th>mm</th> </tr> </thead> <tbody> <tr><td>03</td><td>3/16</td><td>05</td></tr> <tr><td>04</td><td>1/4</td><td>06</td></tr> <tr><td>05</td><td>5/16</td><td>08</td></tr> <tr><td>06</td><td>3/8</td><td>10</td></tr> <tr><td>08</td><td>1/2</td><td>13</td></tr> <tr><td>10</td><td>5/8</td><td>16</td></tr> <tr><td>12</td><td>3/4</td><td>19</td></tr> <tr><td>16</td><td>1</td><td>25</td></tr> <tr><td>20</td><td>1 1/4</td><td>32</td></tr> <tr><td>24</td><td>1 1/2</td><td>38</td></tr> <tr><td>32</td><td>2</td><td>51</td></tr> <tr><td>40</td><td>2 1/2</td><td>64</td></tr> <tr><td>48</td><td>3</td><td>76</td></tr> <tr><td>64</td><td>4</td><td>102</td></tr> <tr><td>96</td><td>6</td><td>152</td></tr> <tr><td>128</td><td>8</td><td>203</td></tr> <tr><td>160</td><td>10</td><td>254</td></tr> <tr><td>192</td><td>12</td><td>305</td></tr> </tbody> </table> | Code | in | mm | 03 | 3/16 | 05 | 04 | 1/4 | 06 | 05 | 5/16 | 08 | 06 | 3/8 | 10 | 08 | 1/2 | 13 | 10 | 5/8 | 16 | 12 | 3/4 | 19 | 16 | 1 | 25 | 20 | 1 1/4 | 32 | 24 | 1 1/2 | 38 | 32 | 2 | 51 | 40 | 2 1/2 | 64 | 48 | 3 | 76 | 64 | 4 | 102 | 96 | 6 | 152 | 128 | 8 | 203 | 160 | 10 | 254 | 192 | 12 | 305 | <p>Tolerances on length: +/- 1%</p> <p>* For metric length, put mm after number</p> | <p>Cover Codes Blank if N/A</p> <p>HC = Hypalon L = Silicone NG = Nylon Scuff Guard PC = Polyolefin TS = PTFE Shrink FJ72 = Fry-Sil Jacket FJ72 = Fry-Sil Tape</p> <p>316SS Covers</p> <p>AFS6 = Armor Flex</p> <p>LS12S6 = Lock Section LS16S6 = Lock Section LS20S6 = Lock Section LS24S6 = Lock Section LS32S6 = Lock Section</p> |
| Code | in | mm | | | | | | | | | | | | | | | | | | | | | | | | | | | | | | | | | | | | | | | | | | | | | | | | | | | | | | | | | | | |
| 03 | 3/16 | 05 | | | | | | | | | | | | | | | | | | | | | | | | | | | | | | | | | | | | | | | | | | | | | | | | | | | | | | | | | | | |
| 04 | 1/4 | 06 | | | | | | | | | | | | | | | | | | | | | | | | | | | | | | | | | | | | | | | | | | | | | | | | | | | | | | | | | | | |
| 05 | 5/16 | 08 | | | | | | | | | | | | | | | | | | | | | | | | | | | | | | | | | | | | | | | | | | | | | | | | | | | | | | | | | | | |
| 06 | 3/8 | 10 | | | | | | | | | | | | | | | | | | | | | | | | | | | | | | | | | | | | | | | | | | | | | | | | | | | | | | | | | | | |
| 08 | 1/2 | 13 | | | | | | | | | | | | | | | | | | | | | | | | | | | | | | | | | | | | | | | | | | | | | | | | | | | | | | | | | | | |
| 10 | 5/8 | 16 | | | | | | | | | | | | | | | | | | | | | | | | | | | | | | | | | | | | | | | | | | | | | | | | | | | | | | | | | | | |
| 12 | 3/4 | 19 | | | | | | | | | | | | | | | | | | | | | | | | | | | | | | | | | | | | | | | | | | | | | | | | | | | | | | | | | | | |
| 16 | 1 | 25 | | | | | | | | | | | | | | | | | | | | | | | | | | | | | | | | | | | | | | | | | | | | | | | | | | | | | | | | | | | |
| 20 | 1 1/4 | 32 | | | | | | | | | | | | | | | | | | | | | | | | | | | | | | | | | | | | | | | | | | | | | | | | | | | | | | | | | | | |
| 24 | 1 1/2 | 38 | | | | | | | | | | | | | | | | | | | | | | | | | | | | | | | | | | | | | | | | | | | | | | | | | | | | | | | | | | | |
| 32 | 2 | 51 | | | | | | | | | | | | | | | | | | | | | | | | | | | | | | | | | | | | | | | | | | | | | | | | | | | | | | | | | | | |
| 40 | 2 1/2 | 64 | | | | | | | | | | | | | | | | | | | | | | | | | | | | | | | | | | | | | | | | | | | | | | | | | | | | | | | | | | | |
| 48 | 3 | 76 | | | | | | | | | | | | | | | | | | | | | | | | | | | | | | | | | | | | | | | | | | | | | | | | | | | | | | | | | | | |
| 64 | 4 | 102 | | | | | | | | | | | | | | | | | | | | | | | | | | | | | | | | | | | | | | | | | | | | | | | | | | | | | | | | | | | |
| 96 | 6 | 152 | | | | | | | | | | | | | | | | | | | | | | | | | | | | | | | | | | | | | | | | | | | | | | | | | | | | | | | | | | | |
| 128 | 8 | 203 | | | | | | | | | | | | | | | | | | | | | | | | | | | | | | | | | | | | | | | | | | | | | | | | | | | | | | | | | | | |
| 160 | 10 | 254 | | | | | | | | | | | | | | | | | | | | | | | | | | | | | | | | | | | | | | | | | | | | | | | | | | | | | | | | | | | |
| 192 | 12 | 305 | | | | | | | | | | | | | | | | | | | | | | | | | | | | | | | | | | | | | | | | | | | | | | | | | | | | | | | | | | | |
| <h2>How To Measure Lengths Of Hose Assemblies</h2> <p>Example 1 Measure between the faces of the inserts (including flange retainer insert) Hose assemblies with straight to straight fittings, 37° seat, DIN and Flanged</p> <p>Example 2 Measure from the center of the elbow Hose assemblies with 45° or 90° elbow fittings, 37° seat, DIN and Flanged</p> <p>Example 3 Measure from the center of the gauge point to the other gauge point Hose assemblies with flairless fittings</p> | | | | | | | | | | | | | | | | | | | | | | | | | | | | | | | | | | | | | | | | | | | | | | | | | | | | | | | | | | | | | |
| <p>Sanitary Fitting To End Joints</p> <p>48- Mini Sanitary Flange Fitting 49- Tri-Clamp Sanitary Flange 50- Sanitary Flare Thru 51- Sanitary Step up 52- Sanitary Male I-Line 53- Sanitary Female I-Line 54- Male Bevel Seat 55- Female Bevel Seat</p> | | | | <p>Accessories</p> <p>56- Dust Caps for Tri-Clamp Sanitary Flange</p> <p>Special Fitting To End Joints</p> <p>XX - Specify end type YY - Specify end type</p> | | | | | | | | | | | | | | | | | | | | | | | | | | | | | | | | | | | | | | | | | | | | | | | | | | | | | | | | | |

58TT PTFE Chemical Transfer Hose Assemblies

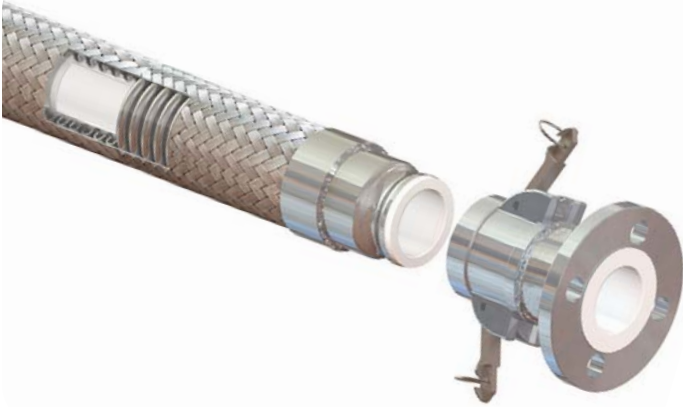

| Thorburn's 58TT PTFE metal hose assemblies |
(PTFE "E" style male camlock hose ends can be attached to various PTFE lined adapters)

Thorburn's 58TT is corrosion resistant and has non-stick properties of virgin unpigmented PTFE. It is designed to pass cycling steam-cold water at 150 psi. The 58TT is a heavy duty containment hose with vent holes incorporated into the design to prevent gas build up between the PTFE liner and the metal hose. The PTFE liner is available smooth-bore and is flared over each end so that the entire wetted flow path is in contact with PTFE. Mating fittings (female coupler to flange male adapter, female coupler to female coupler) can be supplied PTFE lined to maintain full system corrosion resistance. Fittings are welded (not band-clamped) to eliminate any ledge and possible source of contamination. All wetted surfaces of integral male or female fittings are PTFE lined.

FEATURES:

- Available in diameters through 6" I.D. and in lengths to 15 ft.
- Assemblies are subjected to a 10000V spark test
- All wetted pots PTFE, non-wetted pots made of 316SS
- 4 to 1 safety factor for all sizes

APPLICATIONS:

- Chemical or high purity transfer service
- Can be steam-cleaned; ideal for use in "cleaned-in-place" (C.I.P.) applications

HOSE CONSTRUCTION:

Inner Core: Smooth unpigmented PTFE

REINFORCEMENT: Heavy Wall 321 corrugated stainless steel outer hose assembly with 304 stainless steel braid

TEMPERATURE RANGE: -54°C to 205°C (-65°F to 400°F)

| Part Number | Nominal Size | | Nominal I.D. (Lined) | | Nominal O.D. | | Operating Pressure | | Max. Continuous Length | | Min. Bend Radius | | Hose Weight + Male "E" Ends | | Hose Weight | |
|-------------|--------------|-------|----------------------|------|--------------|------|--------------------|-----|------------------------|----|------------------|----|-----------------------------|-------|-------------|-------|
| | DN | in | mm | in | mm | in | bar | psi | m | ft | mm | in | kg/m | lb/ft | kg/m | lb/ft |
| 58TT-16 | 25 | 1 | 22 | 0.88 | 40 | 1.58 | 39 | 571 | 4.6 | 15 | 305 | 12 | 3.39 | 2.28 | 1.53 | 1.03 |
| 58TT-24 | 40 | 1 1/2 | 35 | 1.38 | 58 | 2.28 | 36 | 516 | 4.6 | 15 | 381 | 15 | 5.77 | 3.88 | 2.92 | 1.96 |
| 58TT-32 | 50 | 2 | 48 | 1.88 | 69 | 2.72 | 33 | 472 | 4.6 | 15 | 533 | 21 | 9.05 | 6.08 | 3.97 | 2.67 |
| 58TT-48 | 80 | 3 | 71 | 2.80 | 99 | 3.89 | 22 | 316 | 4.6 | 15 | 711 | 28 | 8.78 | 5.90 | 3.92 | 2.64 |
| 58TT-64 | 100 | 4 | 96 | 3.77 | 126 | 4.98 | 16 | 232 | 4.3 | 14 | 1168 | 46 | 18.4 | 12.37 | 4.72 | 3.17 |
| 58TT-96 | 150 | 6 | 145 | 5.69 | 180 | 7.10 | 11 | 165 | 3.0 | 10 | 1651 | 65 | 34.73 | 23.34 | 10.03 | 6.74 |

How To Order Thorburn 58TT Hose Assemblies

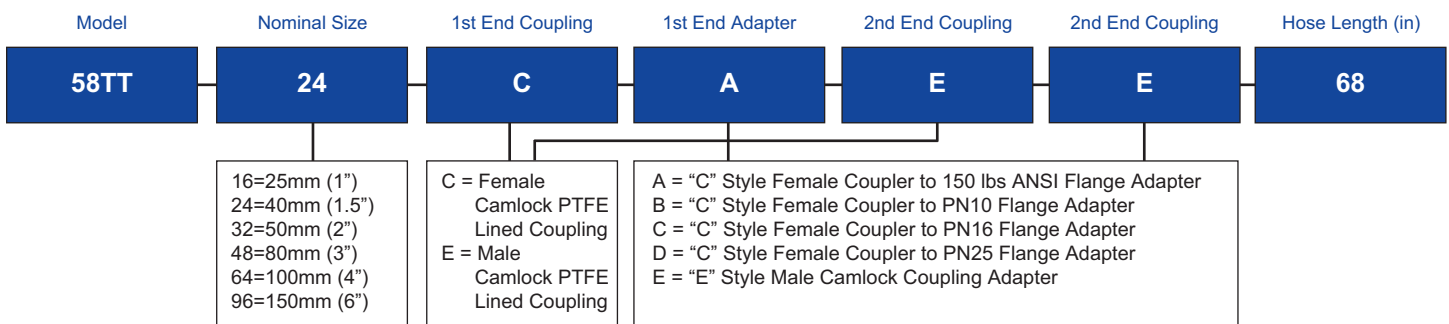

58TT PTFE Hose Adapters

PTFE Lined Type "C" Female Coupler to Flange 150# Adapter | also available in 300#

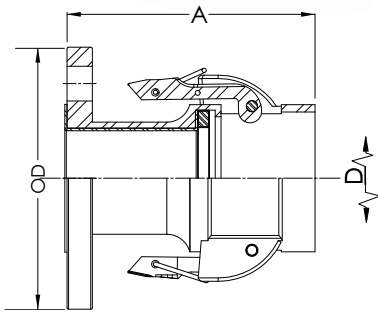

| Part Number | Nominal Flange Size | | Lined I.D. | | A O.A.L. | | D Ext. Cam Arms | | Bolt Circle | Flange O.D. | |
|----------------|---------------------|-----|------------|-----|----------|-----|-----------------|-----|-------------|-------------|-----|
| | Inch | DN | Inch | mm | Inch | mm | Inch | mm | | Inch | mm |
| 633TFF150S6-16 | 1 | 25 | 0.88 | 22 | 3.49 | 89 | 5.04 | 128 | 3 1/8 | 4.25 | 108 |
| 633TFF150S6-24 | 1 1/2 | 40 | 1.38 | 35 | 5.25 | 133 | 7.16 | 182 | 3 7/8 | 5.00 | 127 |
| 633TFF150S6-32 | 2 | 50 | 1.88 | 48 | 5.82 | 148 | 7.54 | 192 | 4 3/4 | 6.00 | 152 |
| 633TFF150S6-48 | 3 | 80 | 2.80 | 71 | 5.82 | 148 | 9.56 | 243 | 6 | 7.50 | 191 |
| 633TFF150S6-64 | 4 | 100 | 3.77 | 96 | 6.39 | 162 | 10.66 | 271 | 7 1/2 | 9.00 | 229 |
| 633TFF150S6-96 | 6 | 150 | 5.69 | 145 | 7.75 | 197 | 16.76 | 426 | 9 1/2 | 11.00 | 279 |

Materials: End fitting adapters 316 Stainless Steel, All wetted parts PTFE lined

PTFE Lined Type "C" Female Coupler to Flange PN10/16 Adapter | also available in PN25

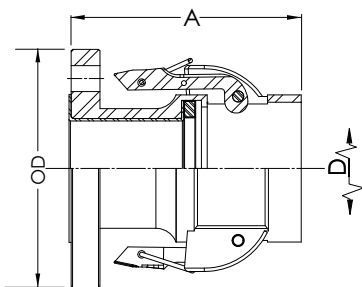

| Part Number | Nominal Flange Size | | Lined I.D. | | A O.A.L. | D Cam Ext. | Bolt Circle | Flange O.D. | |
|-----------------|---------------------|-----|------------|-----|----------|------------|-------------|-------------|-----|
| | Inch | mm | Inch | mm | mm | mm | | Inch | mm |
| 633TFFPN10S6-16 | 1 | 25 | 0.88 | 22 | 89 | 128 | 85 | 4.53 | 115 |
| 633TFFPN10S6-24 | 1 1/2 | 40 | 1.38 | 35 | 133 | 182 | 110 | 5.91 | 150 |
| 633TFFPN10S6-32 | 2 | 50 | 1.88 | 48 | 148 | 192 | 125 | 6.50 | 165 |
| 633TFFPN10S6-48 | 3 | 80 | 2.80 | 71 | 148 | 243 | 160 | 7.87 | 200 |
| 633TFFPN10S6-64 | 4 | 100 | 3.77 | 96 | 162 | 271 | 180 | 8.66 | 220 |
| 633TFFPN10S6-96 | 6 | 150 | 5.69 | 145 | 197 | 426 | 240 | 11.22 | 285 |

Materials: End fitting adapters 316 Stainless Steel, All wetted parts PTFE lined

58TT PTFE Hose Adapters

PTFE Lined Male Type "E" Cam to Flange 150# Adapter | also available in 300#

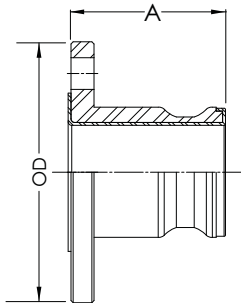

| Part Number | Nominal Flange Size | | Lined I.D. | | A O.A.L. | | Bolt Circle | | Flange O.D. | |
|----------------|---------------------|-----|------------|-----|----------|-----|-------------|-----|-------------|-----|
| | Inch | mm | Inch | mm | Inch | mm | Inch | mm | Inch | mm |
| 633TMF150S6-16 | 1 | 25 | 0.88 | 22 | 2.32 | 59 | 3.13 | 80 | 4.25 | 108 |
| 633TMF150S6-24 | 1 1/2 | 40 | 1.34 | 34 | 3.56 | 90 | 3.88 | 99 | 5.00 | 127 |
| 633TMF150S6-32 | 2 | 50 | 1.72 | 44 | 3.50 | 89 | 4.75 | 121 | 6.00 | 152 |
| 633TMF150S6-48 | 3 | 80 | 2.78 | 71 | 3.69 | 94 | 6.00 | 152 | 7.50 | 191 |
| 633TMF150S6-64 | 4 | 100 | 3.78 | 96 | 4.00 | 102 | 7.50 | 191 | 9.00 | 229 |
| 633TMF150S6-96 | 6 | 150 | 5.56 | 141 | 4.50 | 114 | 9.50 | 241 | 11.00 | 279 |

Materials: End fitting adapters 316 Stainless Steel, All wetted parts PTFE lined

PTFE Lined Male Type "E" Cam to Flange PN10/16 Adapter | also available in PN25

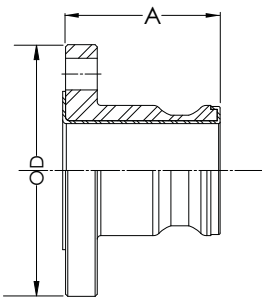

| Part Number | Nominal Flange Size | | Lined I.D. | | A O.A.L. | Bolt Circle | Flange O.D. | |
|-----------------|---------------------|-----|------------|-----|----------|-------------|-------------|-----|
| | Inch | mm | Inch | mm | mm | mm | Inch | mm |
| 633TMFPN10S6-16 | 1 | 25 | 0.88 | 22 | 59 | 80 | 4.25 | 108 |
| 633TMFPN10S6-24 | 1 1/2 | 40 | 1.34 | 34 | 90 | 99 | 5.00 | 127 |
| 633TMFPN10S6-32 | 2 | 50 | 1.72 | 44 | 89 | 121 | 6.00 | 152 |
| 633TMFPN10S6-48 | 3 | 80 | 2.78 | 71 | 94 | 152 | 7.50 | 191 |
| 633TMFPN10S6-64 | 4 | 100 | 3.78 | 96 | 102 | 191 | 9.00 | 229 |
| 633TMFPN10S6-96 | 6 | 150 | 5.56 | 141 | 114 | 241 | 11.00 | 279 |

Materials: End fitting adapters 316 Stainless Steel, All wetted parts PTFE lined

59TT PTFE Lined High Pressure Swivel Flanged Hose Assembly



| 59TT Hose Assembly |

APPLICATIONS:

- Loading/unloading process reactors, storage tanks, tank cars, trucks, etc.
- Chemical transfer

Thorburn’s 59TT Flexible PTFE pipe is a high pressure flanged hose assembly that offers the flexibility and near universal corrosion resistance of PTFE, combined with the high pressure ratings attainable through the use of 321 stainless steel corrugated hose and 304SS over braid. Flexible PTFE pipe assemblies are used as pump connectors and as transfer hose for the loading and unloading of process reactors and vessels, storage tanks, trucks, tank cars, etc. Provided with floating Van Stone flanges, Thorburn Flexible PTFE pipe assemblies can be quickly connected and disconnected. Sizes up to 12 inches available. 4 to 1 safety factor over operating pressure for all sizes.

HOSE CONSTRUCTION:

INNER CORE: Smooth unpigmented PTFE

REINFORCEMENT: Heavy wall corrugated 321 stainless steel outer hose assembly with a single layer of 304 stainless steel braid.

TEMPERATURE RANGE: -54°C to 260°C (-65°F to 500°F) – Consult Thorburn Flex for temperature adjusted pressure ratings.

| Part Number | Nominal Size | | Nominal Liner I.D. | | Nominal O.D. | | Operating Pressure | | Max. Continuous Length | | Min. Bend Radius | | Hose Weight With Flange | | Hose Weight | |
|-------------|--------------|-------|--------------------|-------|--------------|-------|--------------------|-----|------------------------|----|------------------|----|-------------------------|-------|-------------|-------|
| | DN | in | mm | in | mm | in | bar | psi | m | ft | mm | in | kg/m | lb/ft | kg/m | lb/ft |
| 59TT-16 | 25 | 1 | 22 | 0.88 | 40 | 1.58 | 39 | 571 | 4.6 | 15 | 305 | 12 | 5.25 | 3.53 | 1.12 | 0.75 |
| 59TT-24 | 40 | 1 1/2 | 34 | 1.35 | 58 | 2.28 | 36 | 516 | 4.6 | 15 | 381 | 15 | 8.62 | 5.79 | 1.83 | 1.23 |
| 59TT-32 | 50 | 2 | 48 | 1.88 | 69 | 2.72 | 33 | 472 | 4.6 | 15 | 610 | 24 | 14.1 | 9.49 | 2.32 | 1.56 |
| 59TT-48 | 80 | 3 | 71 | 2.80 | 99 | 3.88 | 22 | 316 | 4.6 | 15 | 711 | 28 | 21.5 | 14.44 | 2.98 | 2.00 |
| 59TT-64 | 100 | 4 | 96 | 3.77 | 126 | 4.98 | 16 | 232 | 4.3 | 14 | 1168 | 46 | 32.0 | 21.51 | 3.99 | 2.68 |
| 59TT-96 | 150 | 6 | 146 | 5.75 | 180 | 7.10 | 11 | 160 | 3.0 | 10 | 1245 | 49 | 59.4 | 39.94 | 7.07 | 4.75 |
| 59TT-128 | 200 | 8 | 196 | 7.72 | 236 | 9.28 | 10 | 145 | 3.0 | 10 | 1372 | 54 | 55.0 | 36.95 | 19.9 | 13.4 |
| 59TT-160 | 250 | 10 | 246 | 9.69 | 291 | 11.45 | 9 | 130 | 3.0 | 10 | 1727 | 68 | 76.0 | 51.06 | 28.3 | 19.0 |
| 59TT-192 | 300 | 12 | 296 | 11.65 | 341 | 13.44 | 8 | 116 | 3.0 | 10 | 2057 | 81 | 103.0 | 69.21 | 30.7 | 20.6 |

How to Order Thorburn 59TT Hose Assemblies

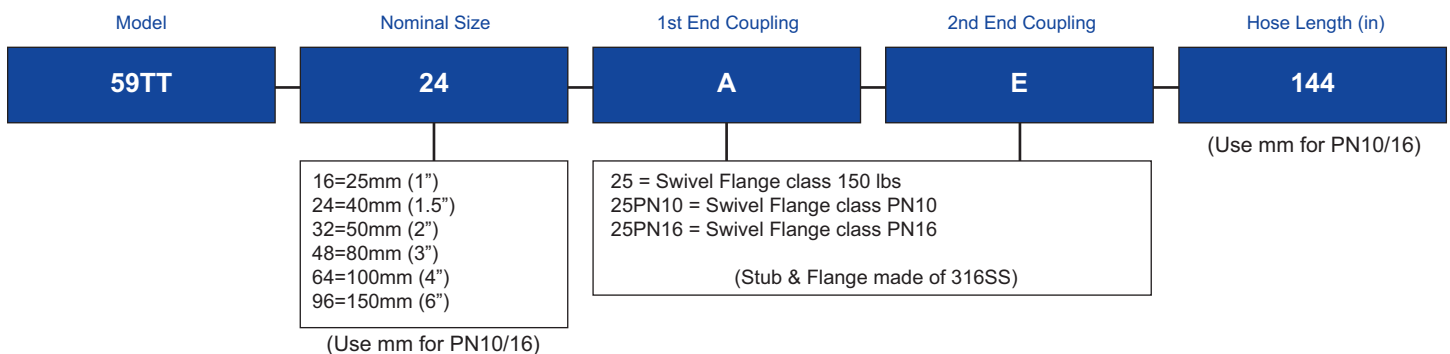

60TT PTFE Hose Assemblies



| 60TT Hose Assembly |

APPLICATIONS:

- Loading/unloading process reactors, storage tanks, tank cars, trucks, etc.
- Chemical, pharmaceutical and food transfer

Thorburn's 60TT Sanaflex is a seamless smooth hose with a flare thru PTFE innercore. Sanaflex hose assemblies combine the corrosion resistance and purity of a smooth bore PTFE lined hose with the advantage of sanitary fittings. A unique one piece integrally moulded PTFE O-Ring gasket provides the following characteristics:

- All wetted surfaces are PTFE
- FDA approved virgin unpigmented PTFE is easily cleaned – ideal for use in "cleaned-in-place" process equipment
- Self-aligning gasket and elimination of loose gasket
- Smooth-bore liner minimizes pressure drop and turbulence
- Elimination of ANSI flanges affords substantial weight reduction

HOSE CONSTRUCTION:

INNER CORE: Smooth unpigmented PTFE

REINFORCEMENT: Heavy wall corrugated 321 stainless steel outer hose assembly with a single layer of 321 stainless steel braid.

ENDS: SA479 Type 316SS material, all lined PTFE

TEMPERATURE RANGE: -54°C to 260°C (-65°F to 500°F) – Consult Thorburn Flex for temperature adjusted pressure ratings.

| Part Number | Nominal Size | | Flange I.D. | | Flange O.D. | | Tube O.D. | | Operating Pressure | | Vacuum HG | | Max. Continuous Length | | Min. Bend Radius | | Hose Weight | |
|-------------|--------------|-------|-------------|------|-------------|------|-----------|-----|--------------------|-----|-----------|-----|------------------------|----|------------------|----|-------------|-------|
| | mm | in | mm | in | mm | in | mm | in | bar | psi | in | mm | m | ft | mm | in | kg/m | lb/ft |
| 60TT-16 | 25 | 1 | 22 | 0.88 | 50 | 1.98 | 25 | 1.0 | 39 | 571 | 26 | 660 | 4.6 | 15 | 305 | 12 | 2.31 | 1.55 |
| 60TT-24 | 40 | 1 1/2 | 35 | 1.37 | 50 | 1.98 | 38 | 1.5 | 36 | 516 | 26 | 660 | 4.6 | 15 | 381 | 15 | 3.97 | 2.67 |
| 60TT-32 | 50 | 2 | 48 | 1.87 | 64 | 2.52 | 51 | 2.0 | 33 | 472 | 24 | 610 | 4.6 | 15 | 533 | 21 | 6.12 | 4.11 |
| 60TT-48 | 80 | 3 | 73 | 2.87 | 91 | 3.58 | 76 | 3.0 | 22 | 316 | 24 | 610 | 4.6 | 15 | 711 | 28 | 6.02 | 4.04 |
| 60TT-64 | 100 | 4 | 97 | 3.83 | 119 | 4.68 | 102 | 4.0 | 16 | 232 | 20 | 509 | 4.3 | 14 | 1168 | 46 | 12.75 | 8.57 |
| 60TT-96 | 150 | 6 | 147 | 5.78 | 167 | 6.56 | 152 | 6.0 | 11 | 165 | 20 | 509 | 3.0 | 10 | 1651 | 65 | 24.20 | 16.26 |

How to Order Thorburn 60TT Hose Assemblies

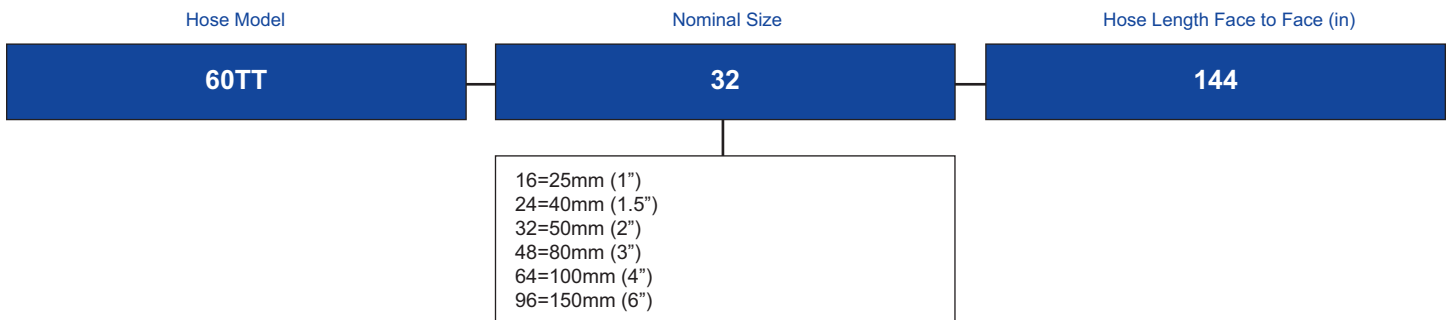

TS46/TS47 PTFE Hose Assemblies



| TS46 (top) and TS47 Hose Assemblies |

APPLICATIONS:

- Transfer of hot compressed gases and steam
- High temperature hydraulic systems, fuel and lubricant handling
- Hot oils, solvents
- Viscous media such as paints and adhesives
- Hot asphalt lines

Thorburn's **TS46/TS47** are PTFE smooth bore hoses that are specifically designed to be used with field attachable fitting to end joints. TS46 is made from virgin extrusion PTFE and TS47 has an antistatic conductive carbon black added to the PTFE to dissipate an electrostatic charge in fuel, steam, or high flow-rate applications.

HOSE CONSTRUCTION:

TS46 INNER CORE: Smooth extruded un-pigmented PTFE

TS47 INNER CORE: Smooth extruded un-pigmented PTFE with added antistatic conductive carbon black

REINFORCEMENT: A580 type 304 (EN1.4301) high tensile multiple stainless steel spiral braid that is pre-tensioned to yield a tight bend radius

TEMPERATURE RANGE: -73°C to 232°C (-100°F to 450°F) – Consult Thorburn Flex for temperature adjusted pressure ratings

STANDARDS:

- SAE 100R14,
- PTFE meets FDA 21 CFR 177.1550 & ISO 12086 Part 1.

| Part Number | Nominal Size | | Nominal I.D. | | Nominal O.D. | | Operating Pressure | | | | Room Temp. Min. Burst | | Min. Bend Radius | | Hose Weight | |
|-----------------|--------------|------|--------------|------|--------------|------|--------------------|------|------|-----|-----------------------|-------|------------------|------|-------------|-------|
| | DN | in | mm | in | mm | in | bar | psi | bar | psi | bar | psi | mm | in | kg/m | lb/ft |
| T46-4 / T47-4 | 8 | 1/4 | 4.76 | 0.25 | 7.87 | 0.31 | 103.4 | 1500 | 13.8 | 200 | 689.5 | 10000 | 50.8 | 2.00 | 0.10 | 0.07 |
| T46-5 / T47-5 | 9 | 5/16 | 6.35 | 0.31 | 9.65 | 0.38 | 103.4 | 1500 | 13.8 | 200 | 620.5 | 9000 | 76.2 | 3.00 | 0.15 | 0.10 |
| T46-6 / T47-6 | 10 | 3/8 | 7.94 | 0.38 | 11.2 | 0.44 | 103.4 | 1500 | 13.8 | 200 | 551.6 | 8000 | 101.6 | 4.00 | 0.16 | 0.11 |
| T46-8 / T47-8 | 15 | 1/2 | 10.3 | 0.50 | 13.7 | 0.54 | 68.9 | 1000 | 13.8 | 200 | 413.7 | 6000 | 133.4 | 5.25 | 0.19 | 0.13 |
| T46-10 / T47-10 | 18 | 5/8 | 12.7 | 0.63 | 16.0 | 0.63 | 55.2 | 800 | 13.8 | 200 | 413.7 | 6000 | 165.1 | 6.50 | 0.25 | 0.17 |
| T46-12 / T47-12 | 20 | 3/4 | 15.9 | 0.75 | 19.3 | 0.76 | 55.2 | 800 | 13.8 | 200 | 344.7 | 5000 | 196.9 | 7.75 | 0.28 | 0.19 |
| T46-16 / T47-16 | 25 | 1 | 22.2 | 1.00 | 25.7 | 1.01 | 55.2 | 800 | 13.8 | 200 | 241.3 | 3500 | 228.6 | 9.00 | 0.42 | 0.28 |

TS46/TS47 Field Attachable Hose Fittings

NO.70 - Male Pipe

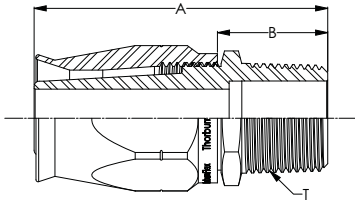

| Part Number | Nominal Hose I.D. | | Conn. Size | | Thread Size | A | | B Cutoff Allowance | | H1 Hex | H2 Hex |
|---------------|-------------------|----|------------|----|-------------|------|----|--------------------|----|--------|--------|
| | Inch | mm | Inch | mm | | Inch | mm | Inch | mm | | |
| TS46-04-02RMP | 1/4 | 6 | 1/8 | 2 | 1/8-27 | 1.38 | 35 | 0.92 | 23 | 0.56 | 0.56 |
| TS46-04-04RMP | 1/4 | 6 | 1/4 | 6 | 1/4-18 | 1.54 | 39 | 1.08 | 27 | 0.56 | 0.56 |
| TS46-05-04RMP | 5/16 | 8 | 1/4 | 6 | 1/4-18 | 1.58 | 40 | 1.07 | 27 | 0.62 | 0.62 |
| TS46-06-04RMP | 3/8 | 10 | 1/4 | 6 | 1/4-18 | 1.66 | 42 | 1.14 | 29 | 0.69 | 0.69 |
| TS46-06-06RMP | 3/8 | 10 | 3/8 | 10 | 3/8-18 | 1.66 | 42 | 1.13 | 29 | 0.69 | 0.69 |
| TS46-08-06RMP | 1/2 | 12 | 3/8 | 10 | 3/8-18 | 1.85 | 47 | 1.22 | 31 | 0.88 | 0.88 |
| TS46-08-08RMP | 1/2 | 12 | 1/2 | 12 | 1/2-14 | 2.10 | 53 | 1.46 | 37 | 0.88 | 0.88 |
| TS46-10-08RMP | 5/8 | 16 | 1/2 | 12 | 1/2-14 | 2.13 | 54 | 1.46 | 37 | 1.00 | 1.00 |
| TS46-12-12RMP | 3/4 | 20 | 3/4 | 20 | 3/4-14 | 2.26 | 57 | 1.61 | 41 | 1.12 | 1.12 |
| TS46-16-12RMP | 1 | 25 | 3/4 | 20 | 3/4-14 | 2.29 | 58 | 1.66 | 42 | 1.38 | 1.38 |
| TS46-16-16RMP | 1 | 25 | 1 | 25 | 1-11 1/2 | 2.50 | 64 | 1.87 | 47 | 1.38 | 1.38 |

Materials: Brass Nipple & Ferrule, Steel Socket, 316SS Nipple, Ferrule & Socket, Anodized Aluminum Nipple, Ferrule & Socket. Material ordering codes are found on Page 91.

NO.71 - Female JIC 37° Flare Swivel

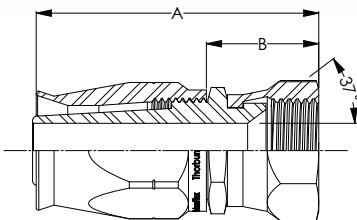

| Part Number | Nominal Hose I.D. | | Conn. Size | | Thread Size | A | | B Cutoff Allowance | | H1 Hex | H2 Hex |
|---------------|-------------------|----|------------|----|-------------|------|----|--------------------|----|--------|--------|
| | Inch | mm | Inch | mm | | Inch | mm | Inch | mm | | |
| TS46-04-04FJX | 1/4 | 6 | 1/4 | 6 | 7/16-20 | 1.58 | 40 | 1.12 | 28 | 0.56 | 0.56 |
| TS46-05-05FJX | 5/16 | 8 | 5/16 | 8 | 1/2-20 | 1.68 | 43 | 1.17 | 30 | 0.62 | 0.62 |
| TS46-06-06FJX | 3/8 | 10 | 3/8 | 10 | 9/16-18 | 1.76 | 45 | 1.24 | 31 | 0.69 | 0.69 |
| TS46-06-08FJX | 3/8 | 10 | 1/2 | 12 | 3/4-16 | 1.85 | 47 | 1.33 | 34 | 0.88 | 0.69 |
| TS46-08-08FJX | 1/2 | 12 | 1/2 | 12 | 3/4-16 | 1.98 | 50 | 1.36 | 35 | 0.88 | 0.88 |
| TS46-10-10FJX | 5/8 | 16 | 5/8 | 16 | 7/8-14 | 2.22 | 56 | 1.55 | 39 | 1.00 | 1.00 |
| TS46-12-12FJX | 3/4 | 20 | 3/4 | 20 | 1 1/16-12 | 2.33 | 59 | 1.68 | 43 | 1.25 | 1.12 |
| TS46-16-16FJX | 1 | 25 | 1 | 25 | 1 5/16-12 | 2.54 | 65 | 1.91 | 49 | 1.50 | 1.38 |

Materials: Brass Nipple & Ferrule, Steel Socket, 316SS Nipple, Ferrule & Socket, Anodized Aluminum Nipple, Ferrule & Socket. Material ordering codes are found on Page 91.

TS46/TS47 Field Attachable Hose Fittings

NO.72 - Female JIC 37° 45° Elbow Flare Swivel

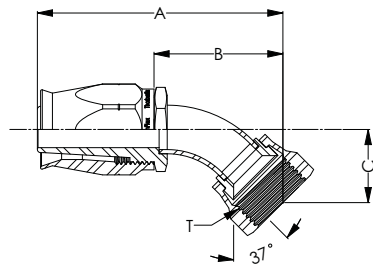

| Part Number | Nominal Hose I.D. | | Conn. Size | | Thread Size | A | | B Cutoff Allowance | | C Drop Dim. | | H1 Hex | H2 Hex |
|-----------------|-------------------|----|------------|----|-------------|------|----|--------------------|----|-------------|----|--------|--------|
| | Inch | mm | Inch | mm | | Inch | mm | Inch | mm | Inch | mm | | |
| TS46-04-04FJX45 | 1/4 | 6 | 1/4 | 6 | 7/16-20 | 1.51 | 38 | 1.05 | 27 | 0.16 | 4 | 0.56 | 0.56 |
| TS46-05-05FJX45 | 5/16 | 8 | 5/16 | 8 | 1/2-20 | 1.62 | 41 | 1.11 | 28 | 0.23 | 6 | 0.62 | 0.62 |
| TS46-06-06FJX45 | 3/8 | 10 | 3/8 | 10 | 9/16-18 | 1.72 | 43 | 1.20 | 30 | 0.28 | 7 | 0.69 | 0.69 |
| TS46-06-08FJX45 | 3/8 | 10 | 1/2 | 12 | 3/4-16 | 2.12 | 53 | 1.59 | 40 | 0.28 | 7 | 0.69 | 0.88 |
| TS46-08-08FJX45 | 1/2 | 12 | 1/2 | 12 | 3/4-16 | 2.27 | 58 | 1.64 | 42 | 0.38 | 10 | 0.81 | 0.88 |
| TS46-10-10FJX45 | 5/8 | 16 | 5/8 | 16 | 7/8-14 | 2.46 | 62 | 1.79 | 45 | 0.46 | 12 | 0.94 | 1.00 |
| TS46-12-12FJX45 | 3/4 | 20 | 3/4 | 20 | 1 1/16-12 | 2.86 | 73 | 2.21 | 56 | 0.58 | 15 | 1.12 | 1.25 |
| TS46-16-16FJX45 | 1 | 25 | 1 | 25 | 1 5/16-12 | 3.12 | 79 | 2.50 | 64 | 0.83 | 21 | 1.38 | 1.50 |

Materials: Brass Nipple & Ferrule, Steel Socket, 316SS Nipple, Ferrule & Socket, Anodized Aluminum Nipple, Ferrule & Socket. Material ordering codes are found on Page 91.

NO.73 - Female JIC 37° 90° Elbow Flare Swivel

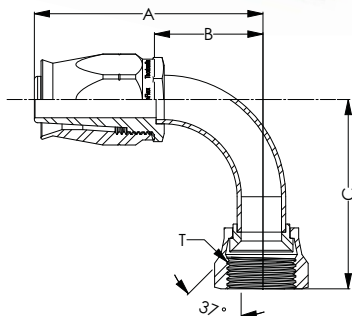

| Part Number | Nominal Hose I.D. | | Conn. Size | | Thread Size | A | | B Cutoff Allowance | | C Drop Dim. | | H1 Hex | H2 Hex |
|-----------------|-------------------|----|------------|----|-------------|------|----|--------------------|----|-------------|----|--------|--------|
| | Inch | mm | Inch | mm | | Inch | mm | Inch | mm | Inch | mm | | |
| TS46-04-04FJX90 | 1/4 | 6 | 1/4 | 6 | 7/16-20 | 1.41 | 36 | 0.95 | 24 | 0.88 | 22 | 0.56 | 0.56 |
| TS46-05-05FJX90 | 5/16 | 8 | 5/16 | 8 | 1/2-20 | 1.52 | 39 | 1.00 | 25 | 0.77 | 20 | 0.62 | 0.62 |
| TS46-06-06FJX90 | 3/8 | 10 | 3/8 | 10 | 9/16-18 | 1.62 | 41 | 1.10 | 28 | 0.85 | 22 | 0.69 | 0.69 |
| TS46-06-08FJX90 | 3/8 | 10 | 1/2 | 12 | 3/4-16 | 1.84 | 47 | 1.25 | 32 | 1.09 | 27 | 0.69 | 0.88 |
| TS46-08-08FJX90 | 1/2 | 12 | 1/2 | 12 | 3/4-16 | 2.03 | 52 | 1.41 | 36 | 1.09 | 27 | 0.81 | 0.88 |
| TS46-10-10FJX90 | 5/8 | 16 | 5/8 | 16 | 7/8-14 | 2.16 | 55 | 1.49 | 39 | 1.23 | 31 | 0.94 | 1.00 |
| TS46-12-12FJX90 | 3/4 | 20 | 3/4 | 20 | 1 1/16-12 | 2.82 | 72 | 2.17 | 55 | 1.82 | 46 | 1.12 | 1.25 |
| TS46-16-16FJX90 | 1 | 25 | 1 | 25 | 1 5/16-12 | 3.10 | 79 | 2.49 | 63 | 2.14 | 54 | 1.38 | 1.50 |

Materials: Brass Nipple & Ferrule, Steel Socket, 316SS Nipple, Ferrule & Socket, Anodized Aluminum Nipple, Ferrule & Socket. Material ordering codes are found on Page 91.

TS46/TS47 Field Attachable Hose Fittings

NO.79 - SAE 45° Inverted Flare Swivel

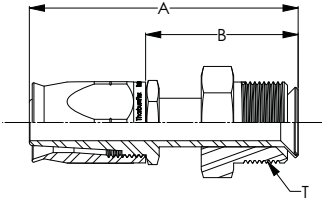

| Part Number | Nominal Hose I.D. | | Conn. Size | | Thread Size | A | | B Cutoff Allowance | | H1 Hex | H2 Hex |
|---------------|-------------------|----|------------|----|-------------|------|----|--------------------|----|--------|--------|
| | Inch | mm | Inch | mm | | Inch | mm | Inch | mm | | |
| TS46-04-04MIS | 1/4 | 6 | 1/4 | 6 | 7/16-24 | 2.12 | 54 | 1.66 | 42 | 0.44 | 0.56 |
| TS46-05-05MIS | 5/16 | 8 | 5/16 | 8 | 1/2-20 | 2.17 | 55 | 1.66 | 42 | 0.50 | 0.62 |
| TS46-06-05MIS | 3/8 | 10 | 5/16 | 8 | 1/2-20 | 2.21 | 56 | 1.69 | 43 | 0.50 | 0.69 |
| TS46-06-06MIS | 3/8 | 10 | 3/8 | 10 | 5/8-18 | 2.21 | 56 | 1.69 | 43 | 0.62 | 0.69 |
| TS46-08-08MIS | 1/2 | 12 | 1/2 | 12 | 3/4-18 | 2.56 | 65 | 1.84 | 47 | 0.75 | 0.81 |
| TS46-10-10MIS | 5/8 | 16 | 5/8 | 16 | 7/8-18 | 2.78 | 71 | 2.11 | 54 | 0.88 | 0.94 |
| TS46-12-12MIS | 3/4 | 20 | 3/4 | 20 | 1 1/16-18 | 3.03 | 77 | 2.37 | 60 | 1.06 | 1.12 |

Materials: Brass Nipple & Ferrule, Steel Socket, 316SS Nipple, Ferrule & Socket, Anodized Aluminum Nipple, Ferrule & Socket. Material ordering codes are found on Page 91.

NO.80 - 45° Elbow SAE 45° Inverted Flare Swivel

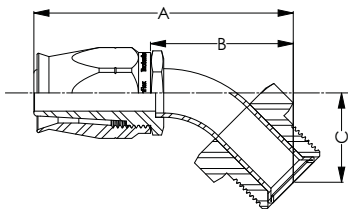

| Part Number | Nominal Hose I.D. | | Conn. Size | | Thread Size | A | | B Cutoff Allowance | | C Drop Dim. | | H1 Hex | H2 Hex |
|------------------|-------------------|----|------------|----|-------------|------|----|--------------------|----|-------------|----|--------|--------|
| | Inch | mm | Inch | mm | | Inch | mm | Inch | mm | Inch | mm | | |
| TS46-04-04-MIS45 | 1/4 | 6 | 1/4 | 6 | 7/16-24 | 2.47 | 63 | 1.99 | 51 | 0.94 | 24 | 0.44 | 0.56 |
| TS46-05-05-MIS45 | 5/16 | 8 | 5/16 | 8 | 1/2-20 | 2.45 | 62 | 1.94 | 49 | 0.94 | 24 | 0.50 | 0.62 |
| TS46-06-05-MIS45 | 3/8 | 10 | 5/16 | 8 | 1/2-20 | 2.49 | 63 | 1.96 | 50 | 0.94 | 24 | 0.50 | 0.69 |
| TS46-06-06-MIS45 | 3/8 | 10 | 3/8 | 10 | 5/8-18 | 2.50 | 64 | 1.96 | 50 | 0.94 | 24 | 0.62 | 0.69 |
| TS46-08-08-MIS45 | 1/2 | 12 | 1/2 | 12 | 3/4-18 | 2.70 | 69 | 2.04 | 52 | 0.94 | 24 | 0.75 | 0.81 |
| TS46-10-10-MIS45 | 5/8 | 16 | 5/8 | 16 | 7/8-18 | 2.95 | 75 | 2.28 | 58 | 1.02 | 26 | 0.88 | 0.94 |
| TS46-12-12-MIS45 | 3/4 | 20 | 3/4 | 20 | 1 1/16-16 | 3.12 | 79 | 2.46 | 62 | 1.02 | 26 | 1.06 | 1.12 |

Materials: Brass Nipple & Ferrule, Steel Socket, 316SS Nipple, Ferrule & Socket, Anodized Aluminum Nipple, Ferrule & Socket. Material ordering codes are found on Page 91.

TS46/TS47 Field Attachable Hose Fittings

NO.81 - 90° Elbow SAE 45° Inverted Flare Swivel

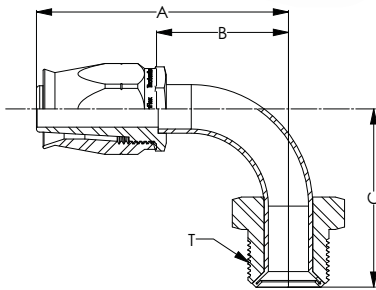

| Part Number | Nominal Hose I.D. | | Conn. Size | | Thread Size | A | | B Cutoff Allowance | | C Drop Dim. | | H1 Hex | H2 Hex |
|------------------|-------------------|----|------------|----|-------------|------|----|--------------------|----|-------------|----|--------|--------|
| | Inch | mm | Inch | mm | | Inch | mm | Inch | mm | Inch | mm | | |
| TS46-04-04-MIS90 | 1/4 | 6 | 1/4 | 6 | 7/16-24 | 2.04 | 52 | 1.57 | 40 | 1.65 | 42 | 0.44 | 0.56 |
| TS46-05-05-MIS90 | 5/16 | 8 | 5/16 | 8 | 1/2-20 | 2.08 | 53 | 1.57 | 40 | 1.64 | 42 | 0.50 | 0.62 |
| TS46-06-06-MIS90 | 3/8 | 10 | 3/8 | 10 | 1/2-20 | 2.12 | 54 | 1.60 | 41 | 1.65 | 42 | 0.50 | 0.69 |
| TS46-06-08-MIS90 | 3/8 | 10 | 1/2 | 12 | 5/8-18 | 2.12 | 54 | 1.60 | 41 | 1.69 | 43 | 0.62 | 0.69 |
| TS46-08-08-MIS90 | 1/2 | 12 | 1/2 | 12 | 3/4-18 | 2.32 | 59 | 1.69 | 43 | 1.78 | 45 | 0.75 | 0.81 |
| TS46-10-10-MIS90 | 5/8 | 16 | 5/8 | 16 | 7/8-18 | 2.66 | 68 | 1.99 | 51 | 2.17 | 55 | 0.88 | 0.94 |
| TS46-12-12-MIS90 | 3/4 | 20 | 3/4 | 20 | 1 1/16-16 | 2.83 | 71 | 2.17 | 55 | 2.17 | 55 | 1.06 | 1.12 |

Materials: Brass Nipple & Ferrule, Steel Socket, 316SS Nipple, Ferrule & Socket, Anodized Aluminum Nipple, Ferrule & Socket. Material ordering codes are found on Page 91.

NO.82 - 2 Hole Swivel Flange

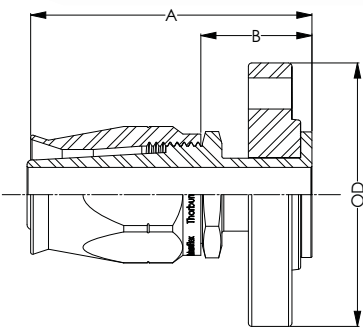

| Part Number | Nominal Hose I.D. | | Conn. Size | | Flange | A | | B Cutoff Allowance | | H1 Hex | H2 Hex |
|----------------|-------------------|----|------------|----|---------|------|----|--------------------|----|--------|--------|
| | Inch | mm | Inch | mm | | Inch | mm | Inch | mm | | |
| TS46-06-12SF2H | 3/8 | 10 | 3/4 | 20 | 7/16-24 | 1.78 | 45 | 0.28 | 7 | 1.00 | 0.69 |
| TS46-12-12SF2H | 3/4 | 20 | 3/4 | 20 | 1/2-20 | 2.08 | 53 | 0.56 | 14 | 1.06 | 1.12 |

Materials: Brass Nipple & Ferrule, Steel Socket, 316SS Nipple, Ferrule & Socket, Anodized Aluminum Nipple, Ferrule & Socket. Material ordering codes are found on Page 91.

TS46/TS47 Field Attachable Hose Fittings

NO.74 - SAE 45° Flare Swivel

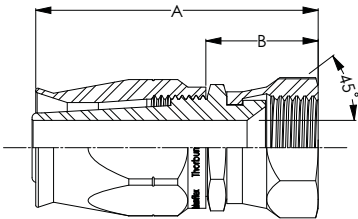

| Part Number | Nominal Hose I.D. | | Conn. Size | | Thread Size | A | | B Cutoff Allowance | | H1 Hex | H2 Hex |
|---------------|-------------------|----|------------|----|-------------|------|----|--------------------|----|--------|--------|
| | Inch | mm | Inch | mm | | Inch | mm | Inch | mm | | |
| TS46-04-04FSX | 1/4 | 6 | 1/4 | 6 | 7/16-20 | 1.58 | 40 | 1.12 | 28 | 0.56 | 0.56 |
| TS46-05-05FSX | 5/16 | 8 | 5/16 | 8 | 1/2-20 | 1.68 | 43 | 1.17 | 30 | 0.62 | 0.62 |
| TS46-06-06FSX | 3/8 | 10 | 3/8 | 10 | 5/8-18 | 1.80 | 46 | 1.28 | 33 | 0.75 | 0.69 |
| TS46-08-06FSX | 1/2 | 12 | 3/8 | 10 | 3/4-16 | 1.85 | 47 | 1.33 | 34 | 0.88 | 0.69 |
| TS46-08-08FSX | 1/2 | 12 | 1/2 | 12 | 3/4-16 | 1.98 | 50 | 1.36 | 35 | 0.88 | 0.88 |
| TS46-10-10FSX | 5/8 | 16 | 5/8 | 16 | 7/8-14 | 2.22 | 56 | 1.55 | 39 | 1.00 | 1.00 |
| TS46-12-12FSX | 3/4 | 20 | 3/4 | 20 | 1 1/16-14 | 2.33 | 59 | 1.67 | 42 | 1.25 | 1.12 |

Materials: Brass Nipple & Ferrule, Steel Socket, 316SS Nipple, Ferrule & Socket, Anodized Aluminum Nipple, Ferrule & Socket. Material ordering codes are found on Page 91.

NO.75 - 45° Elbow SAE 45° Flare Swivel

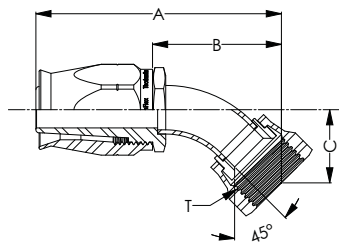

| Part Number | Nominal Hose I.D. | | Conn. Size | | Thread Size | A | | B Cutoff Allowance | | C Drop Dim. | | H1 Hex | H2 Hex |
|-----------------|-------------------|----|------------|----|-------------|------|----|--------------------|----|-------------|----|--------|--------|
| | Inch | mm | Inch | mm | | Inch | mm | Inch | mm | Inch | mm | | |
| TS46-04-04FSX45 | 1/4 | 6 | 1/4 | 6 | 7/16-20 | 1.41 | 36 | 0.95 | 24 | 0.68 | 17 | 0.56 | 0.56 |
| TS46-05-05FSX45 | 5/16 | 8 | 5/16 | 8 | 1/2-20 | 1.52 | 39 | 1.00 | 25 | 0.77 | 20 | 0.62 | 0.62 |
| TS46-06-06FSX45 | 3/8 | 10 | 3/8 | 10 | 5/8-18 | 1.62 | 41 | 1.10 | 28 | 0.85 | 22 | 0.69 | 0.75 |
| TS46-08-08FSX45 | 3/8 | 10 | 1/2 | 12 | 3/4-16 | 1.84 | 47 | 1.25 | 32 | 1.09 | 28 | 0.69 | 0.88 |
| TS46-08-08FSX45 | 1/2 | 12 | 1/2 | 12 | 3/4-16 | 2.03 | 52 | 1.41 | 36 | 1.09 | 28 | 0.81 | 0.88 |
| TS46-10-10FSX45 | 5/8 | 16 | 5/8 | 16 | 7/8-14 | 2.16 | 55 | 1.49 | 38 | 1.23 | 31 | 0.94 | 1.00 |
| TS46-12-12FSX45 | 3/4 | 20 | 3/4 | 20 | 1 1/16-14 | 2.80 | 71 | 2.19 | 56 | 1.82 | 46 | 1.12 | 1.25 |

Materials: Brass Nipple & Ferrule, Steel Socket, 316SS Nipple, Ferrule & Socket, Anodized Aluminum Nipple, Ferrule & Socket. Material ordering codes are found on Page 91.

TS46/TS47 Field Attachable Hose Fittings

NO.76 - 90° Elbow SAE 45° Flare Swivel

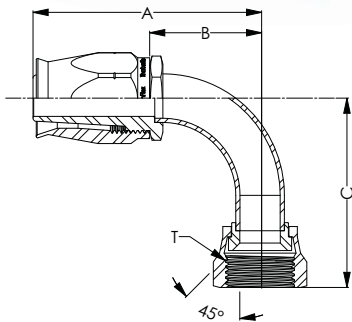

| Part Number | Nominal Hose I.D. | | Conn. Size | | Thread Size | A | | B Cutoff Allowance | | C Drop Dim. | | H1 Hex | H2 Hex |
|-----------------|-------------------|----|------------|----|-------------|------|----|--------------------|----|-------------|----|--------|--------|
| | Inch | mm | Inch | mm | | Inch | mm | Inch | mm | Inch | mm | | |
| TS46-04-04FJX90 | 1/4 | 6 | 1/4 | 6 | 7/16-20 | 1.41 | 36 | 0.95 | 24 | 0.68 | 17 | 0.56 | 0.56 |
| TS46-05-05FJX90 | 5/16 | 8 | 5/16 | 8 | 1/2-20 | 1.52 | 39 | 1.00 | 25 | 0.77 | 20 | 0.62 | 0.62 |
| TS46-06-06FJX90 | 3/8 | 10 | 3/8 | 10 | 5/8-18 | 1.62 | 41 | 1.10 | 28 | 0.85 | 22 | 0.69 | 0.75 |
| TS46-06-08FJX90 | 3/8 | 10 | 1/2 | 12 | 3/4-16 | 1.84 | 47 | 1.25 | 32 | 1.09 | 28 | 0.69 | 0.88 |
| TS46-08-08FJX90 | 1/2 | 12 | 1/2 | 12 | 3/4-16 | 2.03 | 52 | 1.41 | 36 | 1.09 | 28 | 0.81 | 0.88 |
| TS46-10-10FJX90 | 5/8 | 16 | 5/8 | 16 | 7/8-14 | 2.16 | 55 | 1.49 | 38 | 1.23 | 31 | 0.94 | 1.00 |
| TS46-12-12FJX90 | 3/4 | 20 | 3/4 | 20 | 1 1/16-14 | 2.80 | 71 | 2.19 | 56 | 1.82 | 46 | 1.12 | 1.25 |

Materials: Brass Nipple & Ferrule, Steel Socket, 316SS Nipple, Ferrule & Socket, Anodized Aluminum Nipple, Ferrule & Socket. Material ordering codes are found on Page 91.

NO.77 - Straight Tube

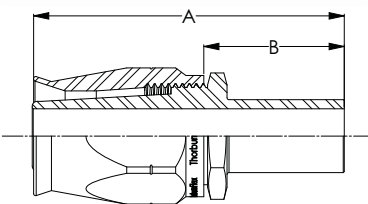

| Part Number | Nominal Hose I.D. | | Conn. Size | | Thread Size | A | | B Cutoff Allowance | | H1 Hex |
|-------------|-------------------|----|------------|----|-------------|------|----|--------------------|----|--------|
| | Inch | mm | Inch | mm | | Inch | mm | Inch | mm | |
| TS46-08-08T | 1/2 | 12 | 1/2 | 12 | 11/16-20 | 2.08 | 53 | 1.44 | 37 | 0.81 |
| TS46-08-10T | 1/2 | 12 | 5/8 | 16 | 13/16-18 | 2.08 | 53 | 1.44 | 37 | 0.81 |
| TS46-10-10T | 5/8 | 16 | 5/8 | 16 | 13/16-18 | 2.16 | 55 | 1.49 | 38 | 0.94 |
| TS46-12-12T | 3/4 | 20 | 3/4 | 20 | 1-18 | 2.42 | 61 | 1.76 | 45 | 1.00 |

Materials: Brass Nipple & Ferrule, Steel Socket, 316SS Nipple, Ferrule & Socket, Anodized Aluminum Nipple, Ferrule & Socket. Material ordering codes are found on Page 91.

TS46/TS47 Field Attachable Hose Fittings

NO.78 - Compression Air Brake Male

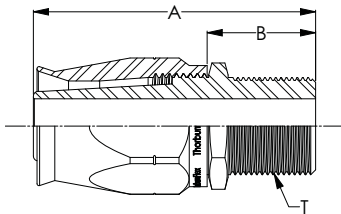

| Part Number | Nominal Hose I.D. | | Conn. Size | | Thread Size | A | | B Cutoff Allowance | | H1 Hex | H2 Hex |
|----------------|-------------------|----|------------|----|-------------|------|----|--------------------|----|--------|--------|
| | Inch | mm | Inch | mm | | Inch | mm | Inch | mm | | |
| TS46-08-08CABM | 1/2 | 12 | 1/2 | 12 | 11/16-20 | 1.68 | 43 | 1.04 | 26 | 0.81 | 0.88 |
| TS46-10-08CABM | 5/8 | 16 | 1/2 | 12 | 11/16-20 | 1.79 | 45 | 1.12 | 28 | 0.94 | 1.00 |
| TS46-10-10CABM | 5/8 | 16 | 5/8 | 16 | 13/16-18 | 1.85 | 47 | 1.18 | 30 | 0.94 | 1.00 |
| TS46-12-12CABM | 3/4 | 20 | 3/4 | 20 | 1-18 | 2.08 | 53 | 1.42 | 36 | 1.06 | 1.12 |

Materials: Brass Nipple & Ferrule, Steel Socket, 316SS Nipple, Ferrule & Socket, Anodized Aluminum Nipple, Ferrule & Socket. Material ordering codes are found on Page 91.

TS46/TS47 Anodized Aluminum Field Attachable Hose Fittings

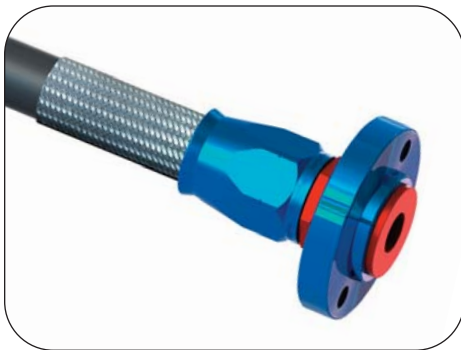

NO. 82 Two Hole Swivel Flange



NO. 70 Male Pipe

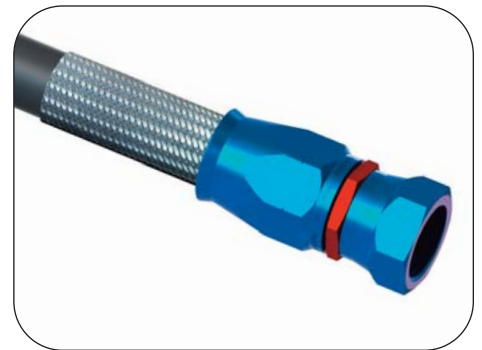

NO. 71 Female JIC 37° Flare Swivel

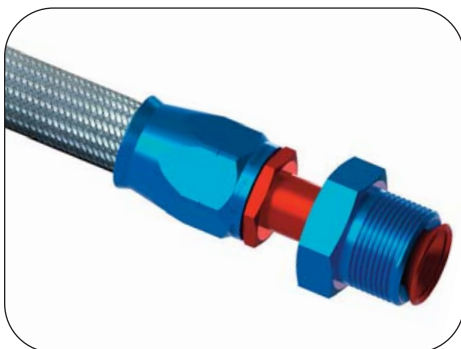

NO. 79 SAE 45° Inverted Flare Swivel

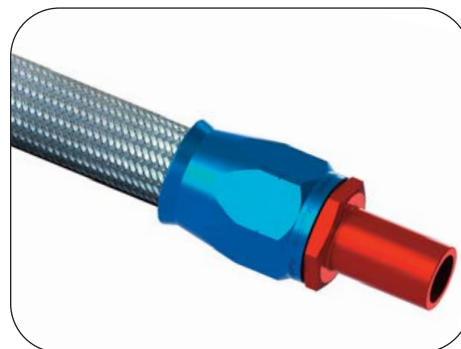

NO. 77 Straight Tube



NO. 78 Compression Air Brake Male



Typical Application For City Transit Buses

- Compressor Discharge
- Brake Lines
- Coolant Transfer
- Freon 12 Transfer
- Fuel and Oil Lines
- Air Conditioning Lines
- Power Steering
- Engine Lines

How To Order TS46/TS47 Hose Assemblies

| Hose Model | Hose Size | Coupling Type | 1st End | 2nd End | Material | Assembly Length (in) | Additional Fractional Length (in) |
|--|--|---------------|---|-------------|-----------|---|-----------------------------------|
| TS46 | 03 | R | 70-8 | 71-8 | S6 | 144 | 3/8 |
| TS46 TS47 | 04 = 1/4" 05 = 5/16" 06 = 3/8" 08 = 1/2" 10 = 5/8" 12 = 3/4" 16 = 1" | R = Reusable | 70 = Male Pipe 71 = JIC 37° Flare Swivel 72 = 45° Elbow JIC 37° Flare Swivel 73 = 90° Elbow JIC 37° Flare Swivel 74 = SAE 45° Flare Swivel 75 = 45° Elbow SAE 45° Flare Swivel 76 = 90° Elbow SAE 45° Flare Swivel 77 = Straight Tube 78 = Compression Air Brake Male 79 = SAE 45° Inv. Flare Swivel 80 = 45° Elbow SAE 45° Inv. Flare Swivel 81 = 90° Elbow SAE 45° Inv. Flare Swivel 82 = 2 Hole Swivel Flange Include Conn. size after End Number | | | For Metric length place "mm" after number Tolerances on length: +/- 1% | 1/4" 3/8" 1/2" 3/4" |
| BC = Brass Nipple & Ferrule, Carbon Steel Socket CC = Carbon Steel Nipple, Ferrule & Socket AA = Anodized Aluminum Nipple, Ferrule & Socket S6 = 316 Stainless Steel Nipple, Ferrule & Socket | | | | | | | |

TS46/TS47 Field Attachable Assembly Instructions

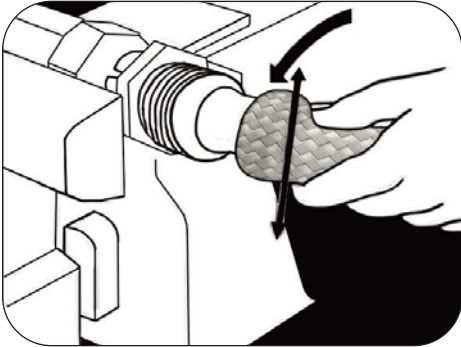

Fig - 1

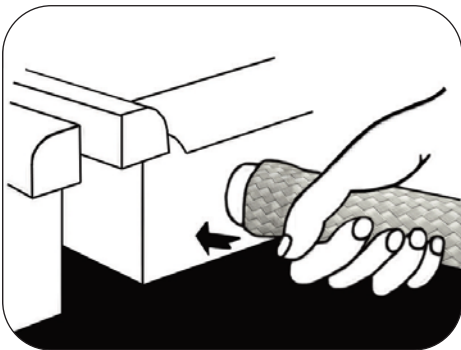

Fig - 2

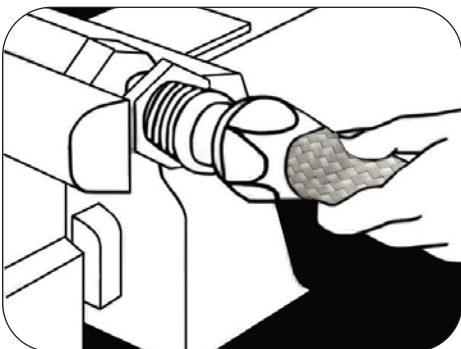

Fig - 3

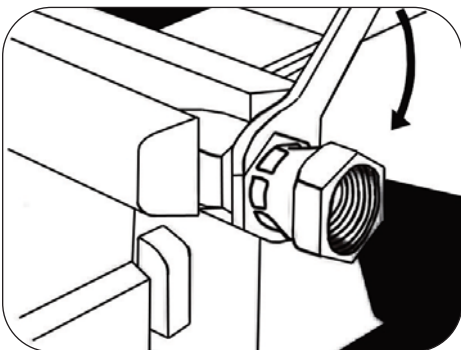

Fig - 4

Cut hose to required length after wrapping area to be cut with a double layer of masking tape; this prevents braid flare and attendant assembly difficulties. Tape is to remain in place until IMMEDIATELY before sliding sockets onto hose.

- Fig-1

CAUTION: Use a sharp hose cut-off blade in a Stratoflex approved hose cut-off machine only. Trim loose wires and clean hose bore. Discard hose if inner tube has been kinked or collapsed or is not cut square within $\pm 6^\circ$. Remove tape and slide sockets onto hose. Put nipple in a vise and push the hose onto the nipple. Rotate hose to size the tube and flare the braid. Remove hose from nipple.

Push the insert onto the hose between the inner tube and the braid. Completely bottom the hose in the insert by pushing against a flat surface.

- Fig-2

Push the insert and hose onto the nipple until the insert bottoms against the nipple chamfer. Lubricate the nipple and socket threads. Push the socket forward and start the threads by hand.

- Fig-3

Tighten the nipple hex with the proper wrench until there is a 1/32" maximum gap between the nipple and socket hexes. To disassemble, reverse the procedure.*

- Fig-4

Clean the hose assembly using paint thinner or other Thorburn approved fluid. Blow the hose bore dry by using filtered air.

- Fig-4

Proof test the hose assembly at twice the recommended operating pressure for 30 seconds minimum, 5 minutes maximum.

- Fig-4

***NOTE:** When attaching the fitting onto the hose, the insert collapses inwardly compressing the inner tube. All components, other than the insert, are considered re-attachable unless visibly damaged.

Potflex™ Potroom Dielectric Flexible Piping



Thorburn's Potflex™ technology was specifically developed to respond to the need for a superior alternative to rubber compressed air dielectric hose assemblies in the aluminum industry. Potflex™ is non-conductive and its state of the art construction dramatically increases flexibility, which simplifies difficult installations, while providing superior pressure and temperature resistancy for longer lasting maintenance free performance

Features and Benefits

- Non-conductive
- High pressure and high temperature service
- Non-aging
- Ultra flexible
- High flow and maintenance free

Potroom and Superstructure Applications

- Pneumatic control lines
- Feeder and crust breaker lines
- Main feed lines
- Main exhaust lines
- General potroom hook-up lines



Aluminerie Alouette aluminum plant in Sept-Îles, Quebec

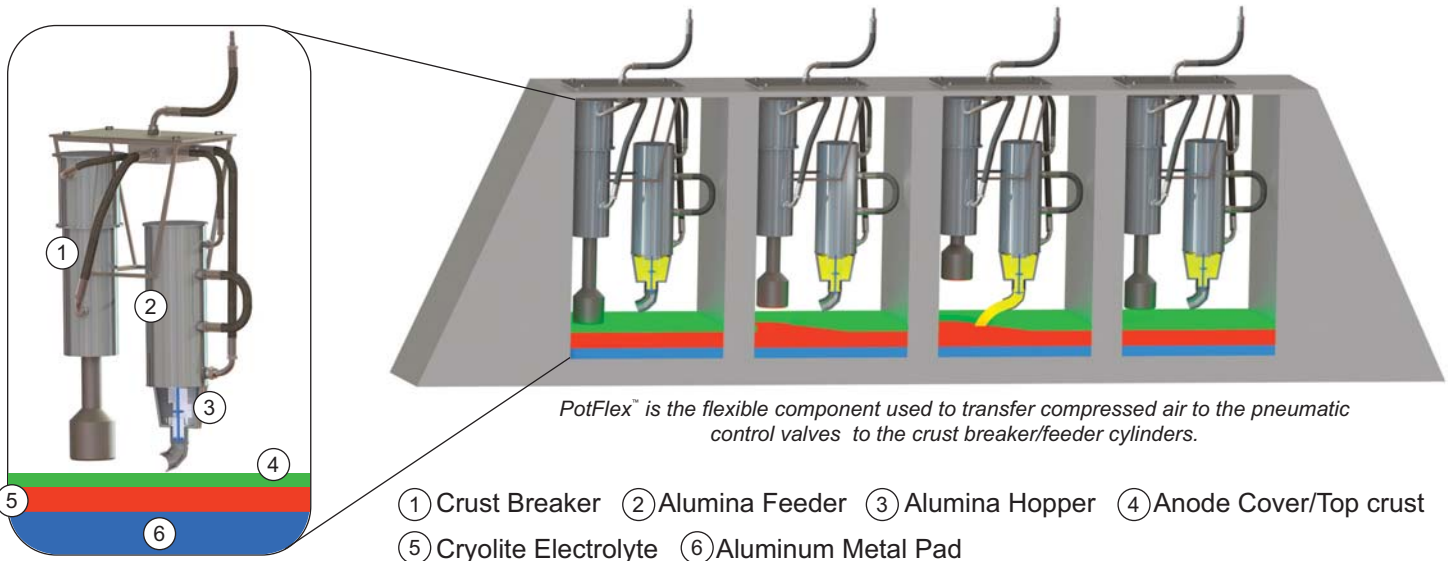

Potflex™ TKP30 Dielectric Hose



| TKP30 Potflex Hose Assembly |

APPLICATIONS:

- Compressed air lines in aluminum smelters
- Coolant
- Oil and fuel
- Instrument lines
- Medium pressure gas systems

Potflex TKP30 is a long term cost-effective, value-engineered solution that:

- Reduces stress in the piping system
- Absorbs and dampens vibration
- Compensates for misalignment and thermal expansion and contraction
- Has controlled volumetric expansion
- Simplifies component installation or servicing

Thorburn's TKP30 is specifically designed for long term service as the flexible component used to transfer compressed air to pneumatic control valves and crust breaker/feeder cylinders found in potroom superstructures of aluminum smelters. TKP30 is completely non-conductive with dead tight sealing to 275 bar and its properties do not change over time, yielding superior maintenance free performance.

FEATURES:

- Non-metallic, non-conductive throughout and flame resistant (will not sustain combustion). These characteristics make it appropriate for sound attenuation, electrical insulation, isolation or resistance to high frequency radiation.
- High tensile strength, Kevlar 29 braid, which makes it better suited for higher temperatures and pressures than Nomex-nylon braided hoses.
- The convoluted lightweight hose is extremely flexible and easy to work with.
- An ideal high pressure dielectric superstructure potroom hose.

HOSE CONSTRUCTION:

Inner Core: Virgin white convoluted PTFE

REINFORCEMENT: PTFE-impregnated fiberglass and a double Kevlar 29 braid, covered with a flame retardant abrasive resistant polyester braid, specifically designed to protect the Kevlar 29 braid from UV degradation.

TEMPERATURE RANGE: 54°C to 175°C (-65°F to 350°F)
-73°C to 204°C (-100°F to 400°F) intermittent service.

| Part Number | Nominal Size | | Nominal I.D. | | Nominal O.D. | | Operating Pressure | | Room Temp. Min. Burst | | Max. Continuous Length | | Min. Bend Radius | | Hose Weight | |
|-------------|--------------|-------|--------------|------|--------------|------|--------------------|------|-----------------------|------|------------------------|----|------------------|------|-------------|-------|
| | DN | in | mm | in | mm | in | bar | psi | bar | psi | m | ft | mm | in | kg/m | lb/ft |
| TKP30-4 | 8 | 1/4 | 6.35 | 0.25 | 11.94 | 0.47 | 68.9 | 1000 | 275.8 | 4000 | 22.9 | 75 | 12.7 | 0.50 | 0.067 | 0.045 |
| TKP30-6 | 10 | 3/8 | 9.65 | 0.38 | 14.5 | 0.57 | 68.9 | 1000 | 275.8 | 4000 | 22.9 | 75 | 19.1 | 0.75 | 0.091 | 0.061 |
| TKP30-8 | 15 | 1/2 | 12.7 | 0.50 | 19.6 | 0.77 | 68.9 | 1000 | 275.8 | 4000 | 15.2 | 50 | 25.4 | 1.00 | 0.185 | 0.124 |
| TKP30-12 | 20 | 3/4 | 19.1 | 0.75 | 25.7 | 1.01 | 68.9 | 1000 | 275.8 | 4000 | 9.14 | 30 | 50.8 | 2.00 | 0.274 | 0.184 |
| TKP30-16 | 25 | 1 | 25.4 | 1.00 | 33.3 | 1.31 | 68.9 | 1000 | 275.8 | 4000 | 9.14 | 30 | 76.2 | 3.00 | 0.357 | 0.240 |
| TKP30-20 | 32 | 1 1/4 | 31.8 | 1.25 | 39.1 | 1.54 | 51.7 | 750 | 206.8 | 3000 | 9.14 | 30 | 88.9 | 3.50 | 0.399 | 0.268 |
| TKP30-24 | 40 | 1 1/2 | 38.1 | 1.50 | 45.7 | 1.80 | 43.1 | 625 | 172.4 | 2500 | 9.14 | 30 | 101.6 | 4.00 | 0.521 | 0.350 |
| TKP30-32 | 50 | 2 | 50.8 | 2.00 | 59.4 | 2.34 | 34.5 | 500 | 138 | 2000 | 9.14 | 30 | 152.4 | 6.00 | 0.595 | 0.400 |

Comparison of Potflex™ TKP30 Features

Outstanding Electrical Insulation

Potflex™ is completely non-conductive and is therefore a perfect electrical insulator.

Extremely Flexible

Potflex™ permits full flow, small radius bends, facilitates installation and minimizes pressure drop.

High Temperature Resistance

Potflex™ is unaffected by dry, hot thermal aging to 204°C continuous (232°C intermittent).

Non-Aging

Potflex™ properties do not change with time, yielding continuous superior maintenance free performance.

Leak Tight Sealing

Potflex™ has a leak tight seal to 275 bar.

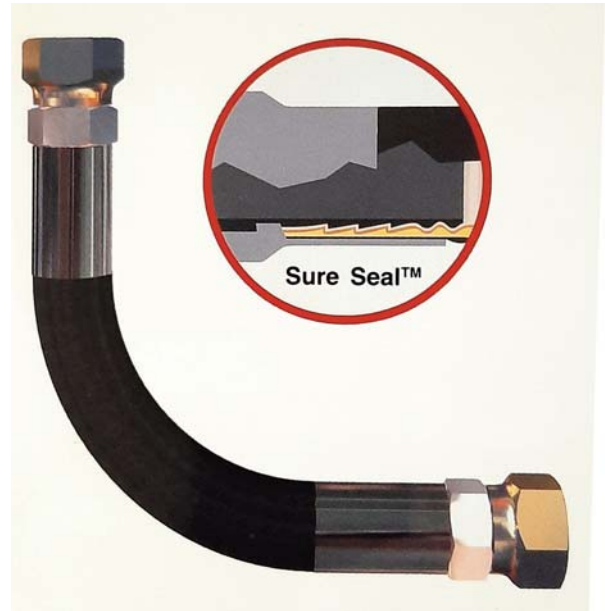

Typical Rubber Dielectric Flexible Piping

Inadequate Electrical Insulation

Requires insulation bushing that decreases flexibility and increases pressure drop.

Unsupported Flexibility - Bending Deforms Hose

Hose kinks easily and increases pressure drop.

Insufficient Temperature Resistance

Temperature adversely affects rubber by accelerating its aging process, resulting in premature cracking, drying out, expensive down time and maintenance replacement costs.

Low Pressure Temperature Containment

The dry hot 120°C to 170°C temperature results in the premature embrittlement and burst failure of the hose.



Potflex™ TKP30 Dielectric Hose Coupling System



Male NPTF style Code 1 - Male BSPT style Code 2



Female JIC 37° Swivel style Code 3



Staubli compatible quick coupling plug style Code 4 | Staubli push button coupler

Thorburn's Potflex™ Series TKP30 hose couplings are attached through a proprietary positive braid locking system called Sure Seal™. This unique coupling to hose connection system ensures a continuous long term, leak tight, seal with a high flowing orifice that will not leak or blow off before the burst pressure of the hose.

Materials

Plated carbon steel (standard). Also available in stainless steel and anodized aluminum.

Options

Staubli™ compatible Potflex™ TKP30 hose coupling plugs are designed to connect to Staubli™ quick release sockets.

Staubli™ is a registered trademark of Staubli International AG

How To Order Potflex™ TKP30 Series Hose Assemblies

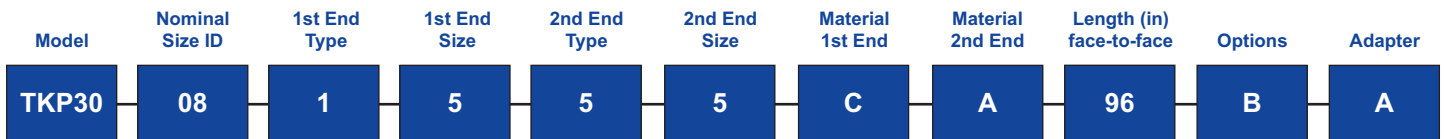

| Code | in | DN |
|------|-------|----|
| 04 | 1/4 | 08 |
| 06 | 3/8 | 10 |
| 08 | 1/2 | 15 |
| 12 | 3/4 | 20 |
| 16 | 1 | 25 |
| 20 | 1 1/4 | 32 |
| 24 | 1 1/2 | 40 |
| 32 | 2 | 50 |

Coupling End Type

- 1 = Male NPTF
- 2 = Male BSPT
- 3 = Female JIC 37° Swivel
- 4 = Staubli Coupling Compatible Plug*
- X = Other (Specify)

* Specify Staubli Series RCS ,RBE, etc. Staubli™ is a registered trademark of Staubli International AG

A = Anodized Aluminum
C = Carbon Steel Plated
S6 = 316SS

Add suffix "mm" for length in millimeters

Options

- B** = Bend restrictor (specify length and end 1st, 2nd)
- F** = Fry-Sil Jacket
- S** = Silicone Sponge
- X** = Specify

Coupling End Size

| Code | Nominal Size mm (in) | NPTF Thread Size | BSPT Thread Size | JIC Female Thread Size |
|------|----------------------|------------------|------------------|------------------------|
| 1 | 6 (1/4) | 1/4-18 | 1/4-19 | 7/16-20 |
| 2 | 10 (3/8) | 3/8-18 | 3/8-19 | 9/16-18 |
| 3 | 12 (1/2) | 1/2-14 | 1/2-14 | 3/4-16 |
| 4 | 16 (5/8) | | 5/8-14 | 7/8-14 |
| 5 | 18 (3/4) | 3/4-14 | 3/4-14 | 1 1/16-12 |
| 6 | 25 (1) | 1-11 1/2 | 1-11 | 1 5/16-12 |
| 7 | 32 (1 1/4) | 1 1/4-11 1/2 | 1 1/4-11 | 1 5/8-12 |
| 8 | 38 (1 1/2) | 1 1/2-11 1/2 | 1 1/2-11 | 1 7/8-12 |
| 9 | 50 (2) | 2-11 1/2 | 2-11 | 2 1/2-12 |

Adapter

Insert "A" if adapter is required and specify

i.e. 348FS-12X12

559T(W) PTFE Hose Assemblies

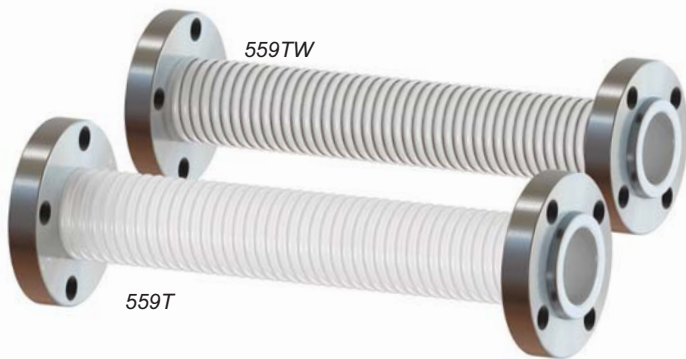

| Thorburn Models 559T & 559TW PTFE Hose Assemblies |

APPLICATIONS:

- Chemical processing
- Deionized water transfer
- Food and beverage processing
- Medical, laboratory and robotics
- Paint spray systems
- Pharmaceutical processing and packaging
- Ultra-pure fluid systems
- Pure air systems
- Push-pull cable jacketing

Thorburn's 559T Hose Assemblies offer the flexibility and universal corrosion resistance of PTFE. Thorburn's 559T are used as a flexible element to transfer corrosive media in process reactors and vessels. 559TW hose is available with external root wire made of 316SS (**Code S6**) material to increase tight radius bending stability. Standard flanges are 316SS (**Code S6**) Material 150# Drilling. Also available in type Vinyl Ester Fiberglass (**Code VEF**) composite.

ADVANTAGES:

- Unmatched corrosive resistant capabilities
- Non-stick, self cleaning and low coefficient of friction
- Meets Pharmacopoeia Class VI & 3A standards
- Ultra flexible and resistant to temperature fluctuations
- Properties do not change over time
- 4 to 1 safety factor for all sizes

HOSE CONSTRUCTION:

Inner Core: Pure unpigmented corrugated PTFE.

559T(W) is available with Polypropylene, Kynar and SS304 braid for higher pressure applications

REINFORCEMENT: External root reinforcement (**Code W**) wire to increase tight radius bending stability.

TEMPERATURE RANGE: -50°C to 260°C (-58°F to 392°F)

| Part Number | Nominal Size | | Nominal I.D. | | Nominal O.D. | | Wall Thickness | | Operating Pressure | | Max. Continuous Length | | Min. Bend Radius | | Hose Weight | |
|-------------|--------------|-------|--------------|------|--------------|------|----------------|----|--------------------|-----|------------------------|------|------------------|------|-------------|-------|
| | DN | in | mm | in | mm | in | mm | in | bar | psi | m | ft | mm | in | kg/m | lb/ft |
| 559T(W)-16 | 25 | 1 | 25 | 0.98 | 36 | 1.41 | 1.5 | 35 | 2.41 | 35 | 3.4 | 11.2 | 60 | 2.36 | 0.40 | 2.89 |
| 559T(W)-20 | 32 | 1 1/4 | 30 | 1.65 | 42 | 1.65 | 1.5 | 28 | 1.93 | 28 | 3.4 | 11.2 | 75 | 2.95 | 0.50 | 3.62 |
| 559T(W)-24 | 40 | 1 1/2 | 38 | 2.08 | 53 | 2.09 | 2.0 | 20 | 1.38 | 20 | 3.4 | 11.2 | 80 | 3.15 | 1.00 | 7.23 |
| 559T(W)-32 | 50 | 2 | 50 | 2.51 | 64 | 2.52 | 2.0 | 20 | 1.38 | 20 | 3.4 | 11.2 | 130 | 5.12 | 1.10 | 7.96 |
| 559T(W)-40 | 65 | 2 1/2 | 65 | 3.19 | 81 | 3.19 | 2.0 | 20 | 1.38 | 20 | 3.4 | 11.2 | 215 | 8.46 | 1.10 | 7.96 |
| 559T(W)-48 | 80 | 3 | 75 | 3.66 | 93 | 3.66 | 2.0 | 13 | 0.90 | 13 | 2.9 | 9.5 | 240 | 9.45 | 1.50 | 10.9 |
| 559T(W)-64 | 100 | 4 | 86 | 4.17 | 106 | 4.17 | 2.0 | 13 | 0.90 | 13 | 2.9 | 9.5 | 300 | 11.8 | 1.70 | 12.3 |
| 559T(W)-96 | 150 | 6 | 127 | 6.14 | 156 | 6.14 | 2.5 | 13 | 0.90 | 13 | 2.4 | 7.9 | 400 | 15.8 | 4.50 | 32.5 |

559T(W) PTFE Hose Assemblies



Pharmaceutical powder filling machine



Food processing plant

Pharmaceutical

The properties of PTFE has many benefits for the Pharmaceutical industry where high purity and sanitation are necessary. PTFE does not require passivation or electro-polishing is impervious to cracking and rarely requires repair. Furthermore, PTFE is chemically inert, non-reactive and permanently resistant to steam sterilisation (SIP) and in-place cleaning (CIP).

Food and Beverage

PTFE tubing is by far the most widely specified material for Food & Beverage processing applications of all types, including the production of dairy products, powders, syrups, sauces, processed meats, wine and beer. PTFE is chemically inert therefore the hose will not affect the product whatsoever at operating temperatures ranging from -60°C to +260°C. PTFE will not impart any colour, flavour or odour and will not absorb or remove ingredients.

How to Order Thorburn 159T(W) Hose Assemblies

| Hose Model | Reinforcement | Nominal Size (in) | Ends | Hose Length Face to Face (in) |
|------------|---------------------------------|---|--|--|
| 159T | W | 32 | VEF150 | 144 |
| | W = External Root Reinforcement | For metric place suffix "mm" after number | VEF150 = Vanstone #150 Flange VEFPN10 = Vanstone PN10 Flange VEFPN16 = Vanstone PN16 Flange S6150 = 316SS #150 Flange S6PN10 = 316SS PN10 Flange S6PN16 = 316SS PN16 Flange | For metric length place suffix "mm" after number |

TC818 PTFE Hose Assemblies



| TC818 PTFE Hose Assembly |

APPLICATIONS:

- Chlorine transfer
- Transfer of industrial gases (for high effusion applications consult Thorburn)
- Tank car loading /unloading
- Pulp and paper bleaching

ADVANTAGES:

- More flexible than metal hose; easier to handle
- Virtually stress free flexing for safe continuous flexing applications
- Easy to clean
- Unique visible hose fatigue systems for added safety
- Unloads faster than metal hose

Note: 1/2" chlorine hose is a recommended alternate by the Chlorine Institute to copper tube whips for filling one (1) ton containers, 100 lb. and 150 lb. cylinders at chlorine repackaging plants.

Thorburn's **TC818** hose assemblies are specifically designed for chlorine transfer. Chlorine transfer is recognized as one of the most potentially hazardous hose applications. With the need for safety, reliability and performance, Thorburn has created a unique product to meet the demands of this critical application. Thorburn's TC818 chlorine hose assemblies are internationally accepted and recognized for providing many years of unparalleled safety and performance.

FEATURES:

- Full flow 1" I.D. convoluted Teflon innercore; reinforced with a double layer of PVDF braid.
- Schedule 80 Monel male swage fittings (1" - 11-1/2 NPT).
- C.P.E. rubber abrasion jacket –compounded and pin-pricked for chlorine service.
- Heavy 300 series stainless abrasion jacket retainer – prevents snagging or tearing of jacket ends.

HOSE CONSTRUCTION:

Inner Core: Convoluted PTFE

REINFORCEMENT: PTFE impregnated fiberglass and a double Kynar braid. The 1" and 1-1/2" I.D. hose is further covered by a C.P.E. abrasion jacket, pin pricked for effusion dissipation.

Note: Outer Kynar braid on 1/2" chlorine hose is for abrasion protection only. For quality assurance and traceability, each assembly is stamped with a serial number which is recorded at Thorburn, along with the installation location and date. The hose is also clearly tagged with its pressure and temperature ratings.

TEMPERATURE RANGE: -40°F to 120°F (-40°C to 49°C).

For temperature adjusted temperature ratings consult Thorburn.

STANDARDS:

Exceeds pressure rating requirements of the Chlorine Institute. Specification 135-3.

| Part Number | Nominal Size | | Nominal I.D. | | Nominal O.D. | | Operating Pressure | | Room Temp. Min. Burst | | Max. Continuous Length | | Min. Bend Radius | | Hose Weight | |
|-------------|--------------|-------|--------------|------|--------------|------|--------------------|-----|-----------------------|------|------------------------|----|------------------|------|-------------|-------|
| | DN | in | mm | in | mm | in | bar | psi | bar | psi | m | ft | mm | in | kg/m | lb/ft |
| TC818-08 | 15 | 1/2 | 12 | 0.50 | 19 | 0.75 | 35 | 500 | 138 | 2000 | 15 | 50 | 50 | 2.00 | 0.24 | 0.16 |
| TC818-16 | 25 | 1 | 25 | 1.00 | 30 | 1.50 | 35 | 500 | 138 | 2000 | 15 | 50 | 90 | 3.50 | 0.61 | 0.41 |
| TC818-24 | 40 | 1 1/2 | 38 | 1.50 | 53 | 2.10 | 26 | 375 | 130 | 1875 | 12 | 40 | 152 | 6.00 | 0.88 | 0.59 |
| TC818-32 | 50 | 2 | 50 | 2.00 | 67 | 2.62 | 26 | 375 | 130 | 1875 | 12 | 40 | 241 | 9.50 | 1.29 | 0.87 |

TC818 PTFE Hose Assemblies



Chlorine Unloading Station

How to Order Thorburn TC818 Hose Assemblies

| Hose Model | Hose Size | 1st End & Material | 2nd End & Material | Hose Cover | Length (in) |
|--------------|--|--|--|--|-------------|
| TC818 | 16 | 05M | 05M | R | 120 |
| | 08 = 1/2 (DN 12) 16 = 1 (DN 25) 24 = 1 1/2 (DN 40) 32 = 2 (DN 50) | Ends 03 = Hex Male NPT 04 = Schedule 80 Male NPT 05 = Vanstone Flange#150 06 = Vanstone Flange PN10 07 = Vanstone Flange PN16 Materials H = Hastelloy M = Monel | Hose Covers E = HDPE - High density Polyethylene K = Kynar PVDF Braid R = CPE Pin Pricked | For metric length place suffix "mm" after number | |

Pigtail Compressed Gas Transfer Hose Assemblies



Pigtail hoses on gas cylinder manifold



Pigtail hoses on nitrogen gas manifold

Hoses that are designed for specialty gas applications should provide pressure capacity, but also maintain the purity of gas delivered. Permeation is the term used to describe how gas molecules pass through the pores of a hose. Effusion happens when gases escape out of a hose. If permeation levels are high, diffusion will occur where ambient gases can enter into the gas stream adding contaminants. For this reason, it is not recommended to use rubber type hoses to supply high purity gas because the properties of rubber have high permeation rates.

All metal corrugated hoses, typically 316 stainless steel such as Monel and Hasteloy, have no permeation, but cannot be used with high velocity flow rate applications due to vibration caused by its corrugated inner core. All metal hoses have less flexibility and durability and are prone to stress cracking.

The best hose choice for compressed gas applications are Thorburn's Pigtail Hoses with PTFE or ETFE hose cores. PTFE or ETFE pigtail hoses are high-pressure, low-effusion, light, flexible and economical. They are ideal for many industrial gases and can be ordered with options including threaded ends with CGA nuts and nipples, protective covers, whipchecks and cable guards. They can be cleaned and bagged for O₂ service to CGA G4.1 specifications.

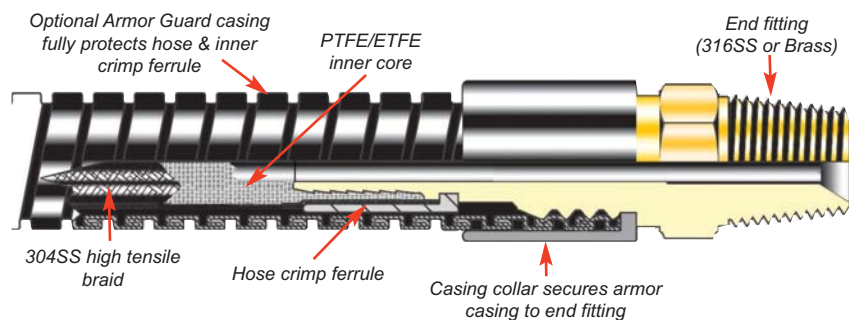

Pigtail Hose Compatibility Guide

| GAS | CONNECTION | A = EXCELLENT B = VERY GOOD C = GOOD D = ACCEPTABLE NA = NOT ACCEPTABLE | | | | |
|-----------------|------------|---|-------|----------------|-------|-------|
| | | TS11/TS12 | TSX17 | TSE110/111/112 | S92Z* | M96Z* |
| Acetylene | 510 | B | A | B | C | C |
| Air | 346 | A | C | A | C | C |
| Argon | 580 | A | C | A | C | C |
| Arsine | 660 | NA | NA | NA | NA | C |
| Carbon Dioxide | 320 | A | C | A | C | C |
| Carbon Monoxide | 350 | B | B | C | A | C |
| Chlorine | 660 | NA | NA | NA | NA | B |
| Fluorine | 679 | NA | NA | NA | NA | B |
| Freon 12 | 660 | A | B | A | A | A |
| Helium | 580 | B | C | B | A | A |
| Hydrogen | 350 | C | C | B | B | C |
| Methane | 350 | A | B | A | A | A |
| Natural Gas | 350 | C | A | C | A | C |
| Nitrogen | 580 | A | A | A | A | C |
| Nitrous Oxide | 326 | A | C | A | C | C |
| Oxygen | 540 | A | C | NA | C | B |

*Ordering and technical details are found in the Thorburn Flex Metallic Hose Catalog

Sintering PTFE Tube



PTFE Sintering Furnace

Post Sintered PTFE Benefits:

- Economically priced
- Lowest effusion rate providing the lowest amount of lost gas in service
- Widest temperature range
- Highest flexibility
- Longest service life
- Meets and exceeds CGA E-9 (2017) section 6.1.6

A PTFE preform has limited cohesive strength and is essentially useless; sintering allows coalescence of the resin particles, which provides strength and void reduction. Sintering cycle profiles of time and temperature affect the final properties of the billet. Sintering temperatures exceed the melting point of PTFE 342°C (648°F) and range from 360°C to 380°C (680–716°F).

First the preform completes its elastic recovery and begins to thermally expand past the PTFE melting point, 342°C (648°F). The expansion can reach up to 25–30% by volume depending upon the type of resin, powder, preforming pressure and temperature.

Above 342°C (648°F), PTFE is a transparent gel due to the absence of a crystalline phase. At the sintering temperature, adjacent melted PTFE particles fuse together and coalesce. After two particles have completely coalesced, they would be indistinguishable from a larger particle and voids are eliminated under the driving force of surface tension. Smaller particle resins and higher preform pressures improve coalescence.

Coalescence and void elimination require time because of the limited mobility of PTFE molecules. The sintering temperature is held for a period of time to allow fusion, coalescence and void elimination to proceed and maximize properties in the part. A time is reached beyond, which the part properties no longer improve, and degradation begins.

TS111/TS112 & TSX117 Pigtail PTFE Hose Assemblies



| TS111/TS112 & TSX117 Pigtail PTFE Hose Assemblies |

TS111/TS112 & TSX117 Features:

- 4 to 1 safety factor
- 100% Hydrostatically tested @ 1.5 times working pressure
- 100% Nitrogen leak tested
- 100% Externally cleaned to remove lubricants and debris
- 100% Oxygen cleaned, dried and bagged to the highest safety standards including CGA-G4-1
- CGA E-9 (2017) Section 6.1.6 Pneumatic effusion requirements

APPLICATIONS:

- Compressed gas cylinder manifolds
- Compressed gas cylinder filling
- Charging lines for aerosols
- Bottle charging
- Dehydration lines
- Breathing equipment
- Medical equipment

Thorburn's TS111/TS112 & TSX117 PTFE Pigtail hose assemblies have become the industry standard for cylinder fill manifolds of many medium and high pressure compressed gases where inherent flexibility, durability and safety are major requirements. PTFE Pigtail hoses surpass the requirements of CGA E.9, and are constructed with a smooth PTFE inner core to handle high velocity gas transfer.

Thorburn's TS111/TS112 & TSX117 PTFE Pigtail hose assemblies use a post-sintering process that re-bakes the PTFE tube material at a controlled temperature and time. The result is an increase in PTFE wall thickness and a tighter molecular bond which substantially reduces the effusion rate of the PTFE. Post-sintering closes the permeation voids (the path that a gas molecule will follow while under pressure) making the PTFE more dense. Thorburn's post-sintered PTFE provides the lowest effusion rate possible while maintaining the highest flexibility and most robust inner core.

In the gas industry, the higher the effusion rate, the higher the loss (\$). Thorburn's models TS111, TS112 & TSX117 are your best option for pigtail hose assemblies.

HOSE CONSTRUCTION:

TS111 Inner Core: Smooth extruded unpigmented PTFE

TS112 Inner Core: Smooth extruded unpigmented PTFE with added zero static conductive carbon black.

TSX117 Inner Core: Smooth extruded unpigmented PTFE with added zero static conductive carbon black. Compliant with ISO 12086 Part 1.

REINFORCEMENT:

TS111/TS112: A580 type 304 (EN1.4301) high tensile stainless steel braid

TSX117: A580 type 304 (EN1.4301) high tensile multiple stainless steel spiral braid that is pre-tensioned to yield a tight bend radius

TEMPERATURE RANGE: 54°C to 204°C (-65°F to 400°F)

| Part Number | Nominal Size | | Nominal I.D. | | Nominal O.D. | | Wall Thickness | | Operating Pressure | | Max. Continuous Length | | Min. Bend Radius | | Hose Weight | |
|--------------|--------------|------|--------------|------|--------------|------|----------------|-------|--------------------|------|------------------------|-----|------------------|----|-------------|-------|
| | DN | in | mm | in | mm | in | mm | in | bar | psi | m | ft | mm | in | kg/m | lb/ft |
| TS11/TS12-05 | 9 | 5/16 | 6.0 | 0.25 | 9.7 | 0.38 | 0.85 | 0.033 | 248 | 3600 | 46 | 150 | 76 | 3 | 0.20 | 0.136 |
| TSX17-04 | 8 | 1/4 | 5.8 | 0.23 | 12.7 | 0.50 | 0.85 | 0.033 | 414 | 6000 | 15 | 50 | 76 | 3 | 0.36 | 0.240 |

TSE110/TSE111 Pigtail ETFE Hose Assemblies



| TSE10/TSE11/TSE17 Pigtail PTFE Hose Assembly |

Thorburn's Ethylenetetrafluorethylene (ETFE) Hose Assemblies are recommended for use in transferring elusive gases such as Helium & Hydrogen in a constant pressurized cylindrical filling application. High effusion rate hoses can let ambient gasses enter the hose line through a reverse process called "defusion" where high purity gas in the hose line can become contaminated. Thorburn's ETFE Hose Assemblies have 1/3 the effusion rate of PTFE hoses and its smooth bore inner core is designed to handle high velocity flow. ETFE has a high melting point and has excellent resistance to chemical reaction, corrosion and stress-cracking.

ADVANTAGES:

- Lower permeability (1/3 lower effusion) than PTFE hose
- High burst pressures, 4 to 1 safety factor
- Brass fittings are CA 360 material
- Hose assemblies tested at 1.5 times rated operating pressure
- In-house oxygen cleaning and bagging
- Better kink resistance and smaller bend radius capability

ETFE ADVANTAGES OVER ALL METAL HOSE:

- Corrugated lining of all metal hoses yield a higher pressure drop when compared to a smooth bore low coefficient of friction ETFE tube.
- Constant flexing will fatigue an all metal hose but has little effect on ETFE tube.
- High velocity can create vibration in corrugated metal hose and will cause stress cracking of the corrugated inner core. ETFE tube is smooth bore and will not vibrate.

APPLICATIONS:

- Charging lines for aerosols
- Bottle charging
- Dehydration lines
- Breathing equipment
- Medical equipment

HOSE CONSTRUCTION:

Inner Core: Smooth bore virgin ETFE - Meets requirements of ASTM D5339

REINFORCEMENT:

TSE110: 1 braid of 304SS

TSE111: 2 braids of 316SS

TEMPERATURE RANGE: -60°C to 150°C (-76°F to 300°F)

STANDARDS:

Meets requirements of ASTM D5339

| Part Number | Nominal Size | | Nominal I.D. | | Nominal O.D. | | Wall Thickness | | Operating Pressure | | Min. Burst Pressure | | Min. Bend Radius | | Hose Weight | |
|-------------|--------------|------|--------------|------|--------------|------|----------------|------|--------------------|------|---------------------|-------|------------------|----|-------------|-------|
| | DIN | in | mm | in | mm | in | mm | in | bar | psi | bar | psi | mm | in | kg/m | lb/ft |
| TSE110-05 | 9 | 5/16 | 6.0 | 0.25 | 11.4 | 0.45 | 1.02 | 0.04 | 207 | 3000 | 827 | 12000 | 76 | 3 | 0.24 | 0.16 |
| TSE111-04 | 8 | 1/4 | 4.8 | 0.19 | 11.4 | 0.45 | 1.02 | 0.04 | 241 | 3500 | 965 | 14000 | 76 | 3 | 0.34 | 0.23 |

Thorburn Model “CSS” Pigtail Hose Assembly Safety System

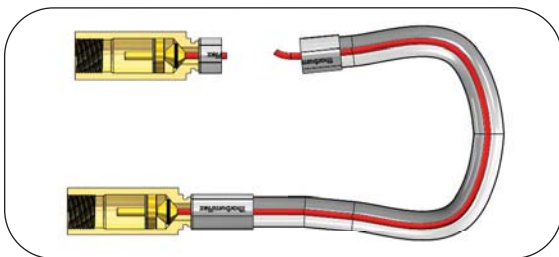
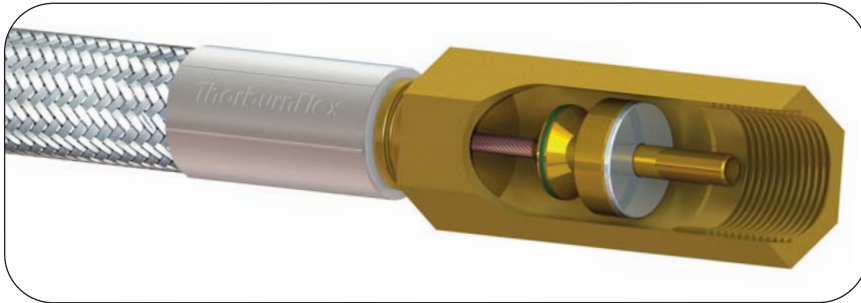

Pull Away Incident

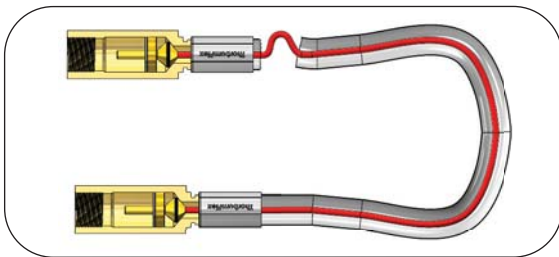

Coupling Ejection

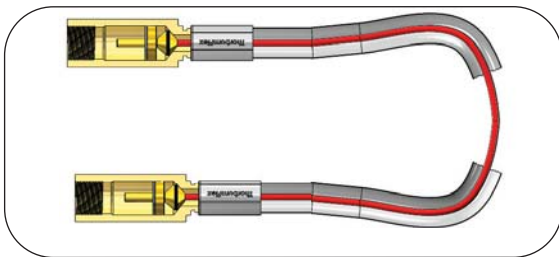

Hose Separation

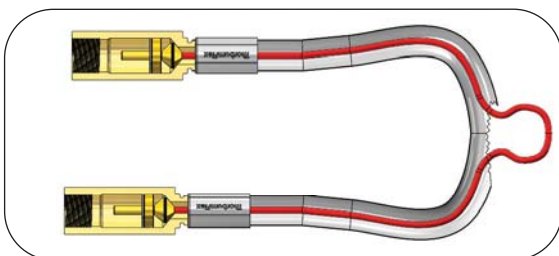

Hose Rupture

Thorburn’s Model “CSS” Pigtail Hose Assembly Safety System is a proven hose technology designed to counteract the hazardous effect of hose rupture or failure during fluid or gaseous transfer operations. A coated cable within the hose bore is connected to the valve plungers, or flappers, and acts as a compression spring providing thrust in the direction of both ends of the hose, holding the valves open. If this thrust is eliminated due to coupling ejection, hose stretching or hose separation, the valves release and instantly seat, stopping the flow in both directions. In the event of a pull-away incident, the Pigtail Hose Assembly Safety System is designed to protect facilities from the potential devastating consequences associated with pull-away incidents.

Pull-Away Incident

Hose assemblies represent the weak-link in any transfer operation, except when a pull-away accident occurs. During a pull-away incident a hose assembly can be exposed to 12,000 to 15,000 lbs. of pull force before it fails. Under these circumstances, the hose assembly may not be the weak-link during a pull-away incident and therefore, can result in additional damage to plant piping, bulk-heads, tank truck piping and loading arms, which can result in an uncontrolled release of a hazardous material.

Coupling Ejection, Hose Separation and Rupture

Any hose assembly can experience a coupling ejection where the fitting separates from the hose or a complete hose separation or rupture during a hazardous chemical transfer operation where an uncontrolled release of the hazardous chemical can occur. Thorburn’s Pigtail Hose Assembly Safety System is designed with a valve integrated in each end fitting, and if the hose assembly experiences a coupling ejection, a complete hose separation or rupture, the integrated valve instantaneously shuts off the flow in both directions. Please note that it is in order for the Pigtail Hose Assembly Safety System to engage, the cable inside the hose assembly must extrude out of the rupture.

Features

- 360° engineered break-away point
- Rugged shock proof design with annular seals
- Built-in bumper feature
- 316SS schedule 80 construction
- Re-buildable
- Custom engineered break-points for specific applications
- Meets 5 to 1 burst specifications

Thorburn's CGA 540 Quick Coupling For Oxygen Service



Thorburn's CGA 540 Coupling With 90° Connector

Designed To Fill Gas Cylinders With Internal Thread

CGA sleeve type quick couplings create a pressure-tight connection on gas cylinders in seconds – without any need for time-consuming screw connections. It is designed to achieve easier and more efficient filling of gas cylinders because it can be connected directly to the standard thread of the gas cylinder. The connector comes equipped with an integrated safety peg to comply with the highest safety standards. It ejects under pressure and effectively prevents any disconnection under pressure. Due to its compact design, it is ideal for use in confined spaces.

Features

- Meets the requirements of CGA 540 oxygen service
- Compatible with oxygen cylinders with male thread (with or without a residual pressure valve) and pressure regulator
- Connection in seconds directly to the cylinder valve thread
- No hand tightening required
- Automatic locking of the sliding sleeve under pressure prevents disconnection at pressures exceeding 5 bar
- Inline or 90° version available
- Jaw locking mechanism
- MAWP: 3750 PSI



How to Order Thorburn Pigtail Gas Transfer Hose Assemblies

| Hose Model | Nominal ID | 1st End | Material | 2nd End | Material | Length (in) | Options |
|---|---|--|--|--|--|---|---|
| A | 03 | 01 | S6 | 01 | S6 | 36 | 0A |
| A = TS11 B = TS12 C = TSX17 D = TSE110 E = TSE111 F = TSE112 | 03 = 3/16 04 = 1/4 05 = 5/16 06 = 3/8 08 = 1/2 | 01 = Male NPT 02 = Female NPT | B = Brass S6 = 306 SS | 01 = Male NPT 02 = Female NPT | B = Brass S6 = 306 SS | Metric length place "mm" after number | WC = Whip Check AG = Armor Guard CSS = Hose Cable Safety System QC = CGA 540 Quick Disconnect QC90 = CGA 540 Quick Disconnect With 90° Connector If no option required - Leave blank |

Other Pigtail Assembly Options



Whip Check



ArmorGuard

Sure Temp™ Electrically Heated Hose

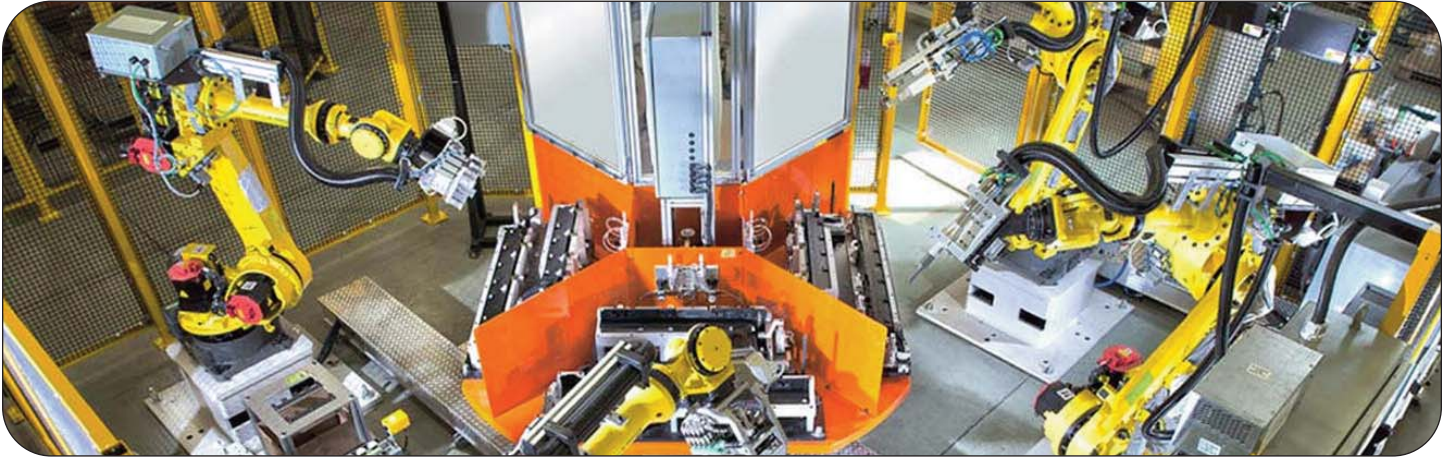

Electrically heated hoses are used wherever a liquid, viscous or melted medium has to be transported from one place to another without losing the temperature. The hose is designed to regulate the temperature of the process fluid entering the hose assembly as it passes through the hose. This is usually required to prevent solidification or an increase in the fluid viscosity. A heating element is spirally wrapped around the hose assembly to regulate the temperature. This self regulating heating element requires a sensor and controller to maintain a specific temperature. Electrical heating, as opposed to steam heating, is preferred because it is more convenient, more controllable and more readily available.



Thorburn's Sure-Temp™ hose assembly



Manufacturing Sure-Temp™ electrically heated hose assembly

Sure-Temp™ with its precise construction using PTFE tubing, stainless steel braided reinforcement and high-performance insulation, provides an internally uniform temperature that is stable throughout the length of the hose, together with great flexibility and sturdiness. When it is necessary to maintain the product temperature at a predefined value, Sure-Temp™ electrically heated hose assemblies provide a constant temperature of the material conveyed through to the application site, without the material temperature being influenced by ambient temperatures and heat losses along the way.

Sure-Temp™ heated hoses are used to:

- Keep media fluid for processing
- Achieve their optimum properties for processing
- Avoid condensation of gaseous media
- Process in a more productive way (robotic applications)
- Ensure consistent quality in manufacturing
- Connect moving parts and devices

Sure Temp™ Electrically Heated Hose

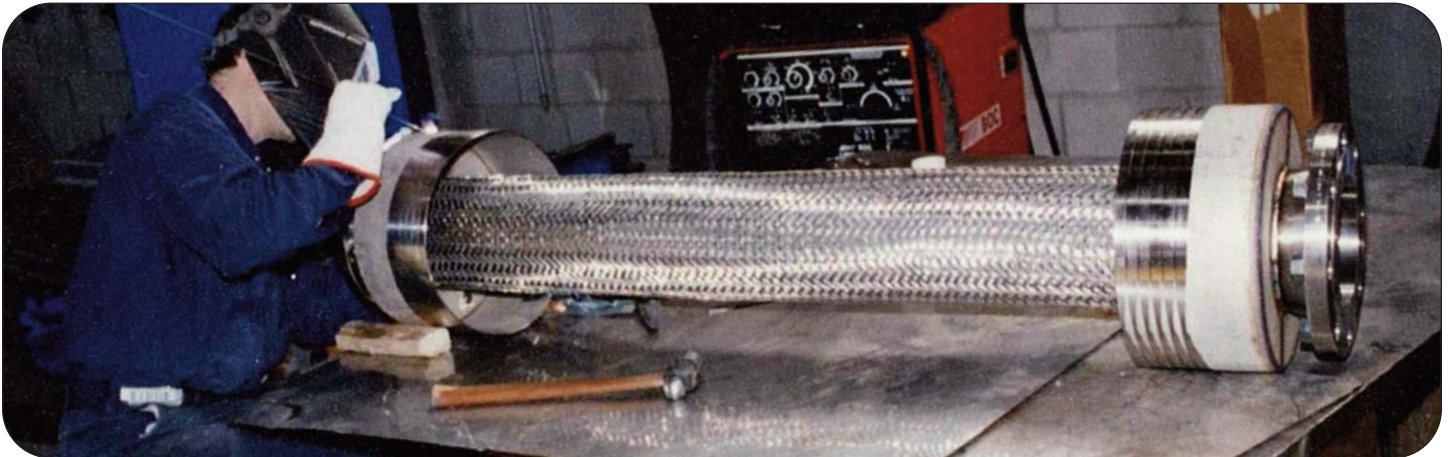

Performing quality check of Sure-Temp™ hose



Custom end fitting on Sure-Temp™ hose assembly

Features & Benefits:

- Easily drained and cleaned
- High mechanical resistive strength
- Uniform heating prevents hot spots
- External temperature controller
- Greatest variety of end fittings for electrically heated hose assemblies
- J or K thermocouplers available
- Standard voltage 120V, 220V, 480V & 600V
- Optional built in temperature control

Specifications:

Heated Pressure Hoses Gas Analysis:

Frost protection/holding temperatures | 5°C to 450°C

Nominal ID | 4mm to 50mm

Typical Design Pressures | Full vacuum to 300 psi (20 bar)

Heated Pressure Hoses Liquid Service:

Frost protection/holding temperatures | 5°C to 250°C

Nominal ID | 8mm to 200mm

Typical Design Pressures | Full vacuum to 300 psi (20 bar)

Sure Temp™ Electrically Heated Hose Assemblies

Available with Factory Mutual Approval for use in Class 1, Div. 2, Group D areas

Sure Temp™ Electrically Heated Hose Construction

Thorburn's Sure Temp™ technology offers the industry the widest range of custom built electrically heated hose assemblies. Sure Temp™ capabilities range from basic freeze protection and gas sampling to transferring viscous materials at precise and uniform temperatures. This enables loading/unloading of oil, fat, resins, paint, bitumen, adhesives, compounds and foods with maximum efficiency, without temperature loss.

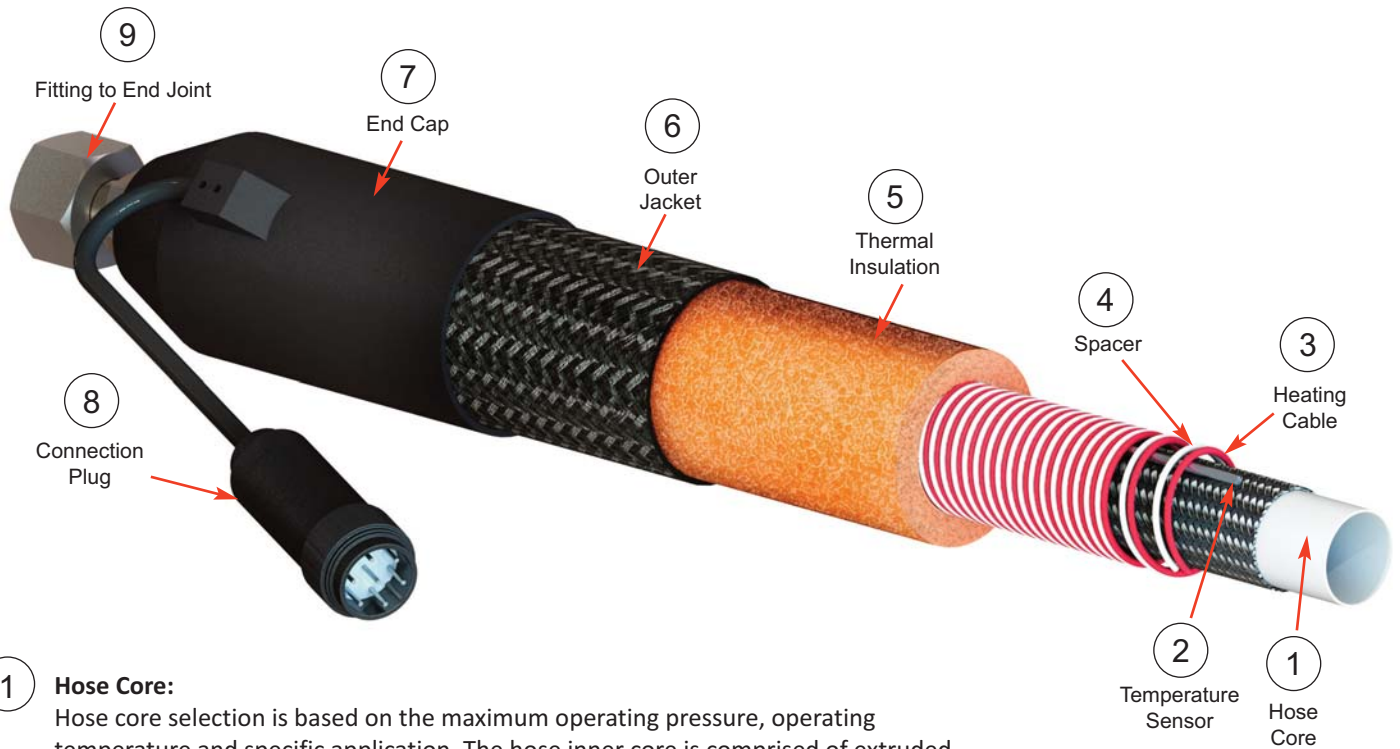

1 Hose Core:

Hose core selection is based on the maximum operating pressure, operating temperature and specific application. The hose inner core is comprised of extruded PTFE, 0.030" or 0.040" wall thickness, which offers exceptional resistance to temperature cycling and kinking.

- Smooth Bore TS Hose Series - Pressure applications
(See page 7 for details)
- Corrugated TC Hose Series - Loading/unloading applications
(See pages 49 to 57 for details)
- Rubber TR Hose Series - Loading/unloading applications
(See page 37 for details)
- Corrugated Metallic Hose - Elusive gases and cryogenic/high temperature >200°C transfer applications
(Please refer to Thorburn's Metallic Hose Catalog pages 5 to 16 for details)



TS Series Hose



TC Series Hose



TR Series Hose



Metal

Sure Temp™ Electrically Heated Hose Construction

- 2 Temperature Sensor:**
The temperature sensor is helically wound around the hose core between the heating cable and helps the temperature controller regulate heat on the hose. 2-wire technology is standard and can be integrated with thermocoupler type K or J.
- 3 Heating Cable:**
The heating cable is comprised of a strong nickel alloy. The power of the heating cable depends on the temperature that must be maintained. Available in single or 3 phase 120V, 240V, 480V & 600V.
- 4 Spacer:**
The spacer is made of braided glass fiber and provides reliable protection for the heating cable against mechanical damage. Optional aluminum foil can be added to the spacer for better heat distribution.
- 5 Thermal Insulation:**
The selection of thermal insulation depends on working temperature.

 - EPDM foam - up to 100°C
 - Silicone foam - up to 250°C
 - Fiberglass or silica cloth - high temperatures above 250°C
- 6 Outer Jacket:**
The outer jacket provides the hose protection against external elements such as weather, humidity and abrasion. Selection of the outer jacket depends upon application, bend radius and ambient temperature.
- 7 End Caps:**
The end caps are used to seal off both ends of the heated hose and provide strain relief for the connection cable. Standard end caps are made of silicone, EPDM, plastic (polyamide) and galvanized metal.
- 8 Connection Cable:**
The electrically heated hose is equipped with a connecting cable 1,5 m long (standard) with or without plug. Plugs are 5 pin (<20A standard) and 7 pin (<10A) configurations.
- 9 Fitting to End Joint:**
The fitting to end joints are a progressive swage or crimp design. Fittings include Female and Male NPT, Female and Male 37° JIC Swivel, Tube stub, Cam & Groove, Sanitary Flange, BSPP, Metric and many other fitting to end joints options.



Installing inner insulation on Sure-Temp™ hose



Preparing Sure-Temp™ hoses for shipment



EPDM



Silicone



Plastic



Metal

Sure Temp™ Electrically Heated Hose Applications



Robotic automotive bonding machine

Plastics processing

- Injection molding
- Extrusion, co-extruders
- Mold-making

Adhesives and dosing systems

- Hot-melt equipment
- Adhesive robots
- Packaging equipment
- Dosing equipment

Surface technology

- Bitumen plants
- Spray-coating plants
- Airless equipment

Isolation technology

- Packaging foam equipment
- PUR foam equipment

Process and environmental technology

- Exhaust gas stations
- Exhaust gas measurement technology
- Sampling probes
- Flue gas analytical
- Emission measurements

Chemical thermal process engineering

- Heavy fuel oil systems
- Chemical pipelines
- Fluid metals
- Silo heating systems

Transportation technology

- Transfer and delivery hoses
- Silo and levelling hoses

Plant and apparatus engineering

- Filling and sealing equipment
- Food processing
- Tool heating

How to Order Thorburn Sure-Temp™ Hose Assemblies

| Hose Type | Size ID X OAL | Hose Core | Sensor | Sensor Position | Heating Cable | Spacer |
|---|--|--|--|---|--|--|
| HHS | 10X24 | TS11 | STP100 | SP300 | HC1 | S1 |
| <p>HHS = Single heated hose</p> <p>HHM2 = Double heated hose</p> <p>HHM3 = Triple heated hose</p> <p>HHM4 = Quad. heated hose</p> | <p>For special length or size please specify</p> | <p>TS Series Smooth Bore PTFE Hose</p> <p>TS11 TS12 TSX16 TSX17 TSX18 TR40</p> <p>TC Series Convoluted Bore PTFE Hose</p> <p>TC72 TC76 TC85 TC87 TC92 TC96 TC97 TC98 TN33 TN34 TP31 TP32</p> | <p>2 Wire Type</p> <p>SPT-100 = 2 Wire (Standard)</p> <p>SPT-25 SPT-50 SPT-200 SPT-500 SPT-1000</p> <p>3 Wire Type</p> <p>SPT-1003W</p> <p>4 Wire Type</p> <p>SPT-1004W</p> <p>Thermocouple</p> <p>STCK = Type K (Ni-Ci-Ni)</p> <p>STCJ = Type J (Fe-CuNi)</p> | <p>SP300 = 300mm (Standard)</p> <p>SP500 = 500mm (Optional)</p> <p>SP600 = 600mm (Optional)</p> <p>Sensor Position is upstream of the power connection</p> | <p>HC1 = PTFE insulating cable (C/W Protective conducting braiding)</p> <p>HC2 = Self regulating (up to 100°C)</p> | <p>S1 = Braided Glass Fiber</p> |
| <p>04 = 1/4 (6mm) X 12 (300mm)</p> <p>06 = 3/8 (10mm) X 24 (600mm)</p> <p>08 = 1/2 (12mm) X 36 (900mm)</p> <p>10 = 5/8 (16mm) X 40 (1000mm)</p> <p>12 = 3/4 (19mm) X 48 (1200mm)</p> <p>16 = 1 (25mm) X 60 (1500mm)</p> <p>20 = 1 1/4 (32mm) X 80 (2000mm)</p> <p>24 = 1 1/2 (40mm) X 88 (2200mm)</p> <p>32 = 2 (50mm) X 100 (2500mm)</p> <p>40 = 2 1/2 (63mm) X 108 (2700mm)</p> <p>48 = 3 (80mm) X 120 (3000mm)</p> <p>64 = 4 (100mm) X 128 (3200mm)</p> <p>96 = 6 (150mm) X 140 (3500mm)</p> <p>160 = 10 (250mm) X 148 (3700mm)</p> <p>196 = 12 (300mm) X 160 (4000mm)</p> | | | | | | |

Sure Temp™ Electrically Heated Hose Applications



Freeze protected chemical loading/unloading



Spraying equipment



Filling Machine



Plastic injection machine



Industrial gluing machine



Flue gas analysis

| Spacer Option | Insulation | Outer Jacket | End Caps | Connection Fittings | Connection Cable | Voltage |
|---|---|---|---|---|---|--|
| AF | I3 | 056 | EC2 | XX | 7 | 115 |
| <p>AF = Aluminum Foil (For improved heat distribution)</p> <p>If not required, leave blank</p> | <p>I1 = Multi-Layered Thermal Fleece</p> <p>I2 = Silicone Foam</p> <p>I3 = EPDM Foam</p> <p>I4 = Glass Silica & Silicone Foam</p> | <p>051 = Corrugated Rubber</p> <p>052 = Corrugated Plastic</p> <p>053 = 304SS Braid</p> <p>054 = Nylon Braid</p> <p>055 = Polyamide Braid</p> <p>056 = Silicone</p> <p>057 = Corrugated 321 Metal Hose</p> | <p>EC1 = Silicone</p> <p>EC1T = Silicone (+ Terminal Housing)</p> <p>EC2 = EPDM</p> <p>EC2T = EPDM (+ Terminal Housing)</p> <p>EC3 = Plastic</p> <p>EC3T = Plastic (+ Terminal Housing)</p> <p>EC4 = Metal</p> <p>EC4T = Metal (+ Terminal Housing)</p> | <p>XX = Male NPT</p> <p>XX = Male BSPT</p> <p>XX = Male JIC</p> <p>XX = Male DIN 24</p> <p>XX = Male DIN 60</p> <p>XX = Female FSX</p> <p>XX = Female O-Seal</p> <p>XX = Female DIN 24</p> <p>XX = Female DIN 60</p> <p>XX = Female Sanitary Flange</p> <p>XX = Female Flange PN10</p> <p>XX = Female Flange PN16</p> <p>XX = Female Flange PN25</p> <p>XX = Female Flange 150#</p> <p>XX = Female Flange 300#</p> <p>XX = Female Flange Encapsulated</p> | <p>5 = 5 Pin Round</p> <p>7 = 7 Pin Round</p> | <p>12 = 12 VAC</p> <p>24 = 24 VAC</p> <p>48 = 48 VAC</p> <p>115 = 115 VAC</p> <p>220 = 220 VAC</p> <p>480 = 480 VAC</p> <p>600 = 600 VAC</p> <p>XX = Other (Specify)</p> |

TFTC-01 Temperature Controllers

The temperature is measured by a sensor processed by the microcontroller and displayed. After comparing actual and preset values, the appropriate output relays are switched.

- LED display works to -25°C
- Programmable -50°C to 500°C
- 16A resistive load alarm contact
- Sensors with 2 or 3 wires



(N)T11 Series - Remote Handling Quick Couplings

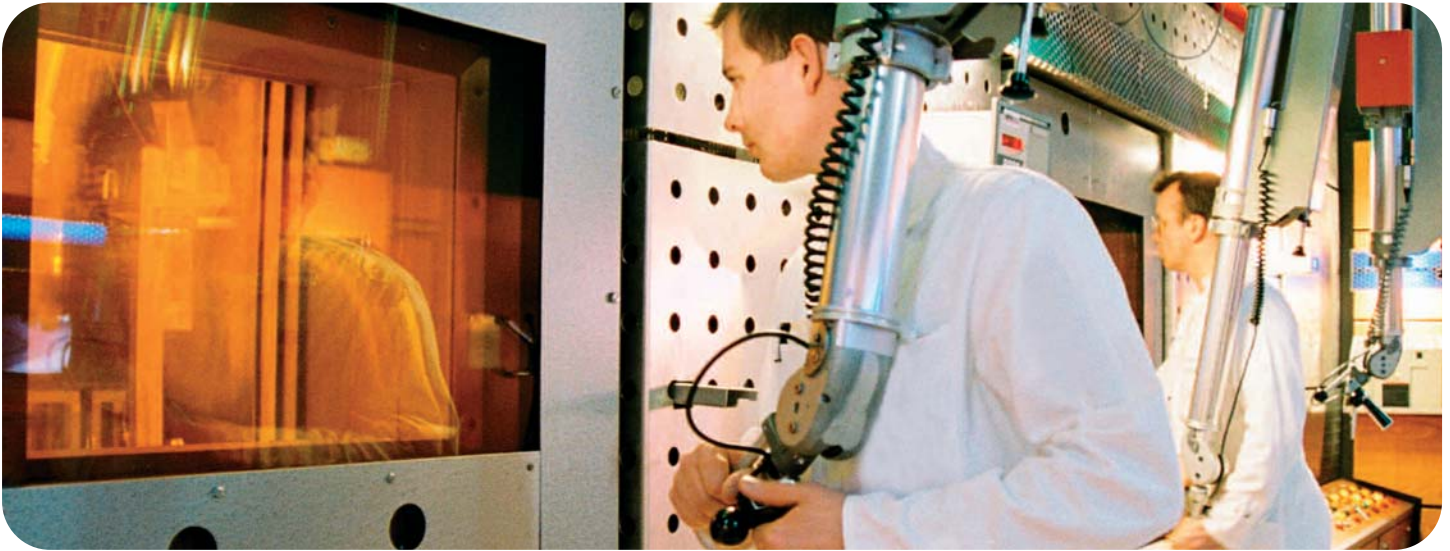

(N)T11 - Quick-release couplings for remote handling of circuits in confinement cells & glove boxes. The long range guiding allows a pre-guiding of the plug into the socket for an easy connection and disconnection.



Features and Benefits

- Specifically designed for remote handling
- Square body for better pincer gripping
- Ribbed faces for improved locking
- Mechanical front stop for more effective axial thrust
- Raised push button for easy disconnection
- Sockets and plugs have identification markings

Applications

- Robotic remote handling
- Gas transfer: hydrogen, argon, nitrogen, helium, etc.
- Corrosive solvents
- High pressure and steam service
- Cryogenic service

Working Temperature for Seals

- Ethylene - Propylene (EPDM) -20°C to 150°C
- Hot water, steam up to 200°C
- Fluorocarbon (FKM) -10°C to 200°C
- Polytetrafluoroethylene (PTFE) -269°C to 250°C
- Acrylonitrile Butadiene (BUNA N) -20°C to 100°C
- Ultra High Molecular Weight Polyethylene (UHMW) -269°C to 80°C

Working Pressure

- 150 bar: DN3 (1/8 in) | DN6 (1/4 in) | DN10 (3/8)
- 100 bar: DN12 (1/2 in) | DN20 (3/4 in)
- 4 to 1 Safety Factor

Construction

- All AISI 316 L Stainless Steel
- Electrolytic polishing optional

Connection Configurations



Fixed socket and plug for remote handling

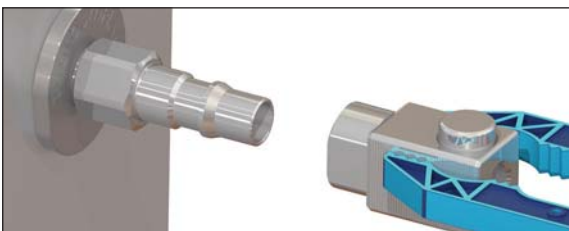

Socket for remote handling and fixed plug

(N)T11 Series - Remote Handling Quick Couplings

Connect/Disconnect Force

| Thorburn Model | | (N)T11-02 | (N)T11-04 | (N)T11-06 | (N)T11-08 | (N)T11-12 |
|------------------------|------------------|-----------|-----------|-----------|-----------|-----------|
| Nominal ID in (DN) | | 1/8 (3) | 1/4 (6) | 3/8 (10) | 1/2 (12) | 3/4 (20) |
| Connecting Force (daN) | | | | | | |
| Double Shut-Off | Without Pressure | <5.5 | <6 | <10.5 | <13 | <13 |
| | Under 6 bar | <6.5 | <10 | <16.5 | <24 | <43 |

| Thorburn Model | | (N)T11-02 | (N)T11-04 | (N)T11-06 | (N)T11-08 | (N)T11-12 |
|------------------------------|------------------|-----------|-----------|-----------|-----------|-----------|
| Nominal ID in (DN) | | 1/8 (3) | 1/4 (6) | 3/8 (10) | 1/2 (12) | 3/4 (20) |
| Connecting Force (daN) | | | | | | |
| Force Applied on Push Button | Without Pressure | <2 | <4 | <15 | <7.5 | <10.5 |
| | Under 6 bar | <2.5 | <4.5 | <6 | <10 | <18 |

Dimensions

| Socket For Remote Handling | Model | Nominal ID in (DN) | Dimensions (mm) | | | |
|----------------------------|------------|--------------------|-----------------|------|------|------|
| | | | Ø | H | H1 | H2 |
| | (N)T1102-S | 1/8 (3) | 21.5 | 17.8 | 16.7 | 16.7 |
| | (N)T1104-S | 1/4 (6) | 32 | 28.5 | 26 | 25 |
| | (N)T1106-S | 3/8 (10) | 40 | 35 | 32 | 31 |
| | (N)T1108-S | 1/2 (12) | 47 | 40.5 | 38 | 37 |
| | (N)T1112-S | 3/4 (20) | 67 | 58 | 55 | 55 |

| Plug For Remote Handling | Model | Nominal ID in (DN) | Dimensions (mm) | |
|--------------------------|------------|--------------------|-----------------|--------------|
| | | | Ø | Square of H |
| | (N)T1102-P | 1/8 (3) | 22 | Square of 18 |
| | (N)T1104-P | 1/4 (6) | 27 | Square of 20 |
| | (N)T1106-P | 3/8 (10) | 35 | Square of 27 |
| | (N)T1108-P | 1/2 (12) | 45 | Square of 36 |
| | (N)T1112-P | 3/4 (20) | 60 | Square of 43 |

Flow Rate/Pressure Drop

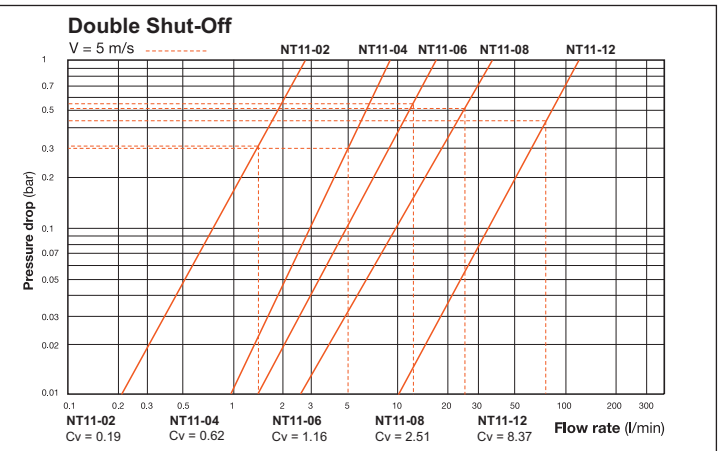
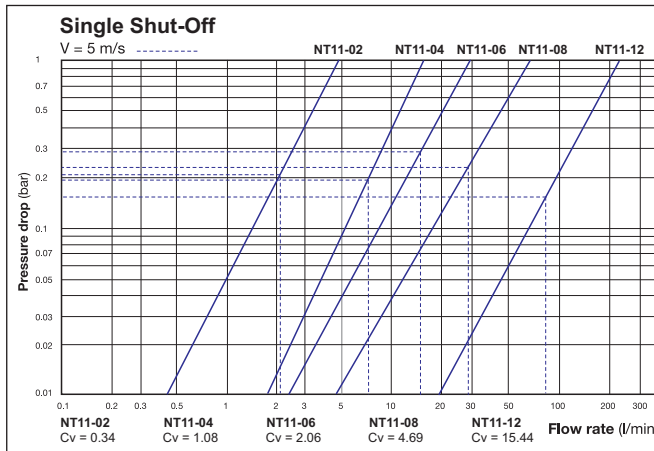

How To Order (N)T11 Series Quick Couplings

| Model | Size | Plug or Socket | Round or Square | Valve | Seal Material | Body Material | End Type |
|---------------------------------|--|------------------------|-------------------------|------------------------|---|--|---|
| (N)T11 | 04 | S | R | V | H | S6 | 02 |
| N = ASME Code full traceability | 02 = 1/8"(DN 3) 04 = 1/4"(DN 6) 06 = 3/8"(DN 10) 08 = 1/2"(DN 12) 12 = 3/4"(DN 20) | P = Plug S = Socket | R = Round S = Square | V = Valved N = None | H = EPDM I = FKM J = PTFE B = BUNA N U = UHMW | S6 = 316SS <i>Nuclear Class 2 insert NC2 after S6.</i> <i>Nuclear Class 3 insert NC3 after S6.</i> <i>Nuclear Class 6 leave blank after S6.</i> | 01 = Female NPT 02 = Male NPT 03 = Male JIC 04 = Male Bulk-head JIC 05 = 2 Sleeve Compression Nut Fitting 06 = Male BSPT 07 = Female BSPP 08 = Hose Barb XX = Specify |

PC = Plug Cap (Plastic)

SC = Socket Cap (316SS)

Accessories - Sold Separately

| Model | Size | Cap |
|--------|------|-----|
| (N)T11 | 04 | SC |

(N)T52 Series - Non-Valved Full Flow Cryogenic Quick Coupling



| Temperature ranges down to -269°C (452°F) |

Thorburn's (N)T52 Series cryogenic quick coupling system is designed, engineered and manufactured to provide safe, reliable, leak tight quick connect and disconnect for cryogenic fluids. It is an ideal quick coupling to replace threaded union type connectors where speed and convenience are a requirement. The (N)T52 standard seals are made of UHMW polyethylene making them ideally suited for radioactive nuclear applications.

Features & Benefits

Ball Bearing Locking Mechanism

- Multiple ball bearings for better load distribution
- Live swivel to eliminate torsion load
- Facilitates alignment during connection

Extended Sleeve Holder

- Larger gripping space

Compression Spring

- Automatically returns the sleeve to its original position

Standard UHMW Polyethylene Seal

- Ideal for liquid nitrogen service in radioactive environments

Ultrasonic Cleaning

- Removes contaminants and minimizes frost build up

Quality & Design

- ASME Section III/CSA N285.0 Classes 1, 2, 3 & 6
- Full traceability of all pressure retaining components
- CRN for all Canadian Provinces

(N)T52 Qualification Testing

Qualification testing under critical operating conditions is required to predict the reliability of a sound quick coupling design. Thorburn's (N)T52 Series Cryogenic couplings are liquid nitrogen tested at -196°C (-320°F) and pressure tested to a minimum of 4 times operating pressure. Further testing includes pneumatic testing at 100 psi submerged in water to verify sealing integrity.



Hydrostatic test at 4000 psi



Pneumatic test at 100 psi



Cryogenic test bench at -320°F



Liquid nitrogen test

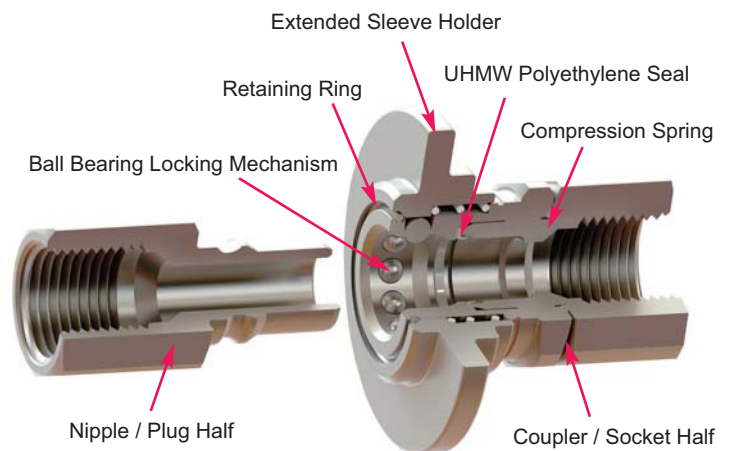

Benefits of UHMW PE (Ultra High Molecular Weight Polyethylene) Seal



- Low temperature up to -452°F without material degradation.
- Self-lubricated material with low coefficient of friction that reduces force required to connect/disconnect coupling halves.
- High impact strength and abrasion resistance that outwears carbon steel 10 to 1.
- Good chemical resistance to organic solvents, degreasing agents and electrolytic attack.
- Very low moisture absorption that prevents ice formation when used for low temperature fluids.

(N)T52 Series - Non-Valved Full Flow Cryogenic Quick Coupling

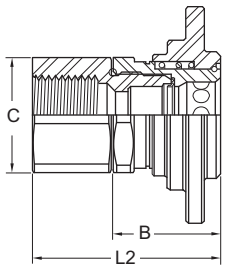

(N)T52 Female Coupler

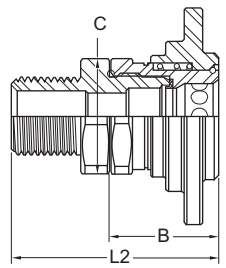

(N)T52 Male Coupler

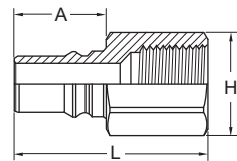

(N)T52 Female Nipple

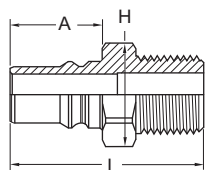

(N)T52 Male Nipple

(N)T52 Coupler Dimensions

| Fitting Size | | L1 | | L2 | | B | | H Hex |
|--------------|----|------|----|------|----|------|----|-------|
| Inch | mm | Inch | mm | Inch | mm | Inch | mm | Inch |
| 3/8 | 10 | 1.86 | 47 | 1.79 | 45 | 1.05 | 27 | 1 |
| 1/2 | 12 | 2.23 | 57 | 2.04 | 52 | 1.17 | 30 | 1 1/4 |
| 3/4 | 20 | 2.44 | 62 | 2.18 | 55 | 1.31 | 33 | 1 1/2 |
| 1 | 25 | 2.74 | 70 | 2.42 | 61 | 1.42 | 36 | 1 7/8 |
| 1 1/2 | 40 | 3.20 | 81 | 2.67 | 68 | 1.67 | 42 | 2 1/2 |
| 2 | 50 | 3.88 | 99 | 3.17 | 81 | 2.17 | 55 | 2 3/4 |

(N)T52 Nipple Dimensions

| Fitting Size | | A | | L | | H Hex |
|--------------|----|------|----|------|----|-------|
| Inch | mm | Inch | mm | Inch | mm | Inch |
| 3/8 | 10 | 0.88 | 22 | 1.69 | 43 | 7/8 |
| 1/2 | 12 | 1.00 | 25 | 2.06 | 52 | 1 |
| 3/4 | 20 | 1.14 | 29 | 2.27 | 58 | 1 1/2 |
| 1 | 25 | 1.25 | 32 | 2.57 | 65 | 1 3/4 |
| 1 1/2 | 40 | 1.50 | 38 | 3.03 | 77 | 2 1/2 |
| 2 | 50 | 2.00 | 51 | 3.71 | 94 | 2 7/8 |

Working Pressure and Force To Connect

| Size (in) | 3/8 | 1/2 | 3/4 | 1 | 1 1/2 | 2 |
|-------------------------|-----|-----|-----|-----|-------|-----|
| Working Pressure (psi)* | 500 | 500 | 500 | 500 | 150 | 150 |
| Force To Connect (lbs) | 2 | 2 | 4 | 5 | 7 | 10 |

* Minimum working pressure is base on a 4:1 safety factor. Higher pressures available.

How To Order (N)T52 Series Couplings

| Model | Size ID | Body Type | Coupler | Size | End | Seal | Material |
|--------|--|---|---|--|--|--|------------|
| (N)T52 | 08 | P | C | 08 | F | U | S6 |
| | Hose size in 1/16 of an inch Examples: 01 = 1/16 02 = 1/8 04 = 1/4 06 = 3/8 08 = 1/2 12 = 3/4 64 = 4 etc. | P = Straight Through Options: SL = Sleeve Lock Place suffix "SL" at end of part number | C = Coupler (Socket) N = Plug (Nipple) | Hose size in 1/16 of an inch Examples: 01=1/16 02=1/8 04=1/4 06=3/8 08=1/2 12=3/4 64=4 etc. | M = Male NPTF F = Female NPTF | T = PTFE U = UHMW X = Other (Specify) | S6 = 316SS |

MT3TL Series - Met-O-Seal



| Thorburn Met-O-Seal with looped handles |

Tanker Truck/Car Loading Quick Coupling

Thorburn's Met-O-Seal Series MT3TL is an all purpose lightweight tanker loading/unloading quick coupling designed for leakproof operation as it cycles through a wide range of temperatures. The design offers a non restrictive flow with no variation in pipe diameter, leak proof operation with cryogenic liquids (LN2, LOX, LH2) and gaseous service.

Features

- Designed for use with liquids or gases from ambient to cryogenic
- Repeatedly reusable low temperature metal to metal seal
- Vents residual pressure prior to complete uncoupling
- Light torque when tightening by hand or wrench to working pressure
- Easily disconnected at cryogenic temperatures, no frost balling
- Reusable primary metal to metal wedge seal
- Thermal cycling compensation

Technical Data

- Leak rates (when connected) 1×10^{-9} std. cc. He/S.
- Full vacuum to 5,000psi, Cryogenics to 1500°F
- Backup seal temperature rating:
 - PTFE -273°C (-459°F) to 204°C (400°F) **Code: J**
 - HNBR -40°C (-40°F) to 150°C (300°F) **Code: N**
 - FKM -40°C (-40°F) to 175°C (350°F) **Code: I**
- Designed and tested to ASME B31.1 & B31.3
- All stainless steel are nitrated to reduce galling

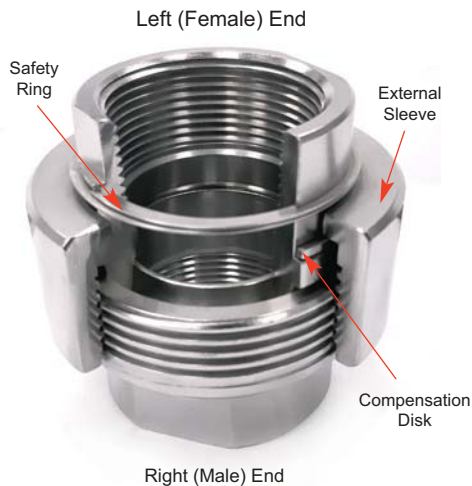

| Part Number | Nominal Size | | Working Pressure | | Minimum Length | |
|-------------|--------------|-----|------------------|-----|----------------|-----|
| | in | mm | psi | bar | in | mm |
| MT3TL16XYM | 1 | 25 | 2400 | 165 | 3.00 | 80 |
| MT3TL24XYM | 1 1/2 | 38 | 2200 | 152 | 3.75 | 95 |
| MT3TL32XYM | 2 | 50 | 2000 | 138 | 4.00 | 102 |
| MT3TL48XYM | 3 | 80 | 1200 | 83 | 5.50 | 140 |
| MT3TL64XYM | 4 | 100 | 750 | 52 | 5.50 | 140 |

How To Order MT3TL Series Met-O-Seal Couplings

| Model | Size ID | Left End | Right End | End Material | Backup Seal Material | External Sleeve Material | Option |
|--------------|---|---|-----------|---|---------------------------------|--|---|
| MT3TL | 32 | 1 | 4 | C | N | S6 | LH |
| | Hose size in 1/16 of an inch Examples: 04 = 1/4 06 = 3/8 08 = 1/2 12 = 3/4 64 = 4 etc. | 1 = Female Thread (NPT) 2 = Male Thread (NPT) 3 = Butt Weld 4 = Socket Weld Female | | C = Carbon Steel (SA105) C1 = Carbon Steel (SA350-LF2) AL = Aluminum S4 = 304SS S6 = 316SS I12 = Alloy 825 H16 = Hastelloy C276 XX = Specify | J = PTFE N = HNBR I = FKM | AL = Aluminum S6 = 316SS C = SA105 C1 = SA350-LF2 | LH = Loop handle sleeve (handle material is same as external sleeve material) |

MTS4 Series - Met-O-Seal



| Thorburn Met-O-Seal Series MTS4 |

Technical Data

- Leak rates (when connected) <math>< 1 \times 10^{-9}</math> std. cc. He/S.
- Full vacuum to 5,000psi, Cryogenics to 1500°F
- Backup seal temperature rating:
 - PTFE** -273°C (-459°F) to 204°C (400°F) **Code: J**
 - HNBR** -40°C (-40°F) to 150°C (300°F) **Code: N**
 - FKM** -40°C (-40°F) to 175°C (350°F) **Code: I**
- Designed and tested to ASME B31.1 & B31.3
- All stainless steel are nitrated to reduce galling
- Light torque when hand tightening to rated pressures

| Part Number | Nominal Size | | Working Pressure | | Minimum Length | |
|-------------|--------------|------|------------------|-----|----------------|------|
| | in | mm | psi | bar | in | mm |
| MTS416XYM | 1/4 | 6 | 5000 | 345 | 2.5 | 63.5 |
| MTS424XYM | 3/8 | 10 | 5000 | 345 | 2.5 | 63.5 |
| MTS432XYM | 1/2 | 12.7 | 4800 | 330 | 2.5 | 63.5 |
| MTS448XYM | 3/4 | 19 | 4600 | 317 | 2.75 | 70 |
| MTS464XYM | 1 | 25 | 4000 | 276 | 2.75 | 70 |
| MTS464XYM | 1 1/2 | 38 | 3800 | 262 | 3.5 | 90 |
| MTS464XYM | 2 | 50 | 3600 | 248 | 4.5 | 114 |
| MTS464XYM | 3 | 80 | 3200 | 221 | 5.5 | 140 |
| MTS464XYM | 4 | 100 | 3000 | 207 | 5.5 | 140 |

Quick Couplings Cryogenic Liquids & Elusive Gases

Thorburn's Met-O-Seal Series MTS4 is a unique, thermally active quick coupling system specifically designed for leak proof make and break connections for operation with cryogenic liquids (LN2, LOX, LH2) and gaseous service. The reusable ferrule seal is made from different materials with different thermal and hardness properties than the coupling ends. Therefore, the seal is strengthened when changes in temperature occur.

Applications

Nuclear Generating Plant:

- Core feeder piping freezing systems LN2 is used to freeze water in the piping during pipe inspection. Met-O-Seal couplings are the cryogenic quick coupling
 - Ion exchangers "Met-O-Seal" replace conventional flanges to allow wrench free operation
 - Steam piping system high temperature/pressure (up to 800°F / 3000 psi)
- High vacuum systems:** Composite building autoclave quick coupling
Cryogenics liquids and elusive gases: LN2, LOX, LH2, H12, etc.



Thorburn's Met-O-Seal Series MTS4 hose coupling used for loading liquid helium in an MRI machine at -269°C (-452°F) just above absolute zero. Magnets at that temperature lose all electrical resistance and become superconducting thus produce the same magnetic field for a thousand years with no more power required.

How To Order MTS4 Series Met-O-Seal Couplings

| Model | Size ID | Left End | Right End | End Material | Backup Seal Material | Ferrule Sleeve Material | External Sleeve Material |
|---|---|---|-----------|---|---------------------------------|-----------------------------|--|
| MTS4 | 16 | 1 | 4 | S6 | J | BR | AL |
| | Hose size in 1/16 of an inch Examples: 04 = 1/4 06 = 3/8 08 = 1/2 12 = 3/4 64 = 4 etc. | 1 = Female Thread (NPT) 2 = Male Thread (NPT) 3 = Butt Weld 4 = Socket Weld Female | | C = Carbon Steel (SA105) C1 = Carbon Steel (SA350-LF2) AL = Aluminum S4 = 304SS S6 = 316SS I12 = Alloy 825 H16 = Hastelloy C276 XX = Specify | J = PTFE N = HNBR I = FKM | AL = Aluminum BR = Brass | AL = Aluminum S6 = 316SS C = SA105 C1 = SA350-LF2 |
| <p>Options (place at end of part number)</p> <p>LH = Loop handle sleeve (handle material is same as external sleeve) None = Leave blank</p> | | | | | | | |

(N)T92H Series - Dry Break High Pressure Quick Coupling

Prevents Resin Valve Blockage & Disconnection Spillage

Thorburn's (N)T92H is a major advancement in quick coupling technology achieving unrestricted full flow during operation and drip free double shut-off drybreak disconnection. The (N)T92H environmentally focused quick coupling system is specifically designed to prevent chemical spills, reduce vapor emissions of volatile organic compounds (VOCs) and enhance operator safety. Its full flow smooth bore design means better flow even for highly viscous fluids.

The (N)T92H coupling system consists of a female end having a concave ball valve and a male end having a convex ball valve that are precision machined to eliminate any spaces between the ball valves. A quarter turn of the ball valve securely seals the process fluids within the line. The (N)T92H coupling can even provide a seal when solids are suspended in the media such as radioactive D₂O resins in PHWR nuclear power stations. Thorburn's (N)T92H has a built-in swivel end that eases alignment regardless of pipe or hose orientation and has a unique locking mechanism that prevents accidental spillage. It is ideally suited for tank truck and tank car transfer systems where environmental compliance is not an option and operator safety is a company culture.

Features

- **Zero spillage** during disconnection eliminates hazardous chemical waste pollution even when solids are suspended in the media.
- **Unrestricted high flow** during operation reduces pressure drops.
- **Eliminates chemical waste** incineration and disposal costs.
- **Reduces liability exposure**, loss time and worker compensation claims.
- **Built in swivel** eases alignment regardless of hose orientation.
- **Protects the installation assets** from hazardous waste product.
- **Prevents radio active D₂O resin blockage** between the valves in a PHWR nuclear power station.

Advantages

- Easy push & turn connection
- The valves cannot be opened when coupling is disconnected
- The coupling cannot be disconnected when the valves are open
- Reliable dry break with poppet valves

Applications

- Transfer of LIN/LOX/LAR, CO₂, Nitrous Oxide & LNG
- Loading/unloading of tank trucks, rail tankers
- Container discharge
- Fuel bunkering
- Vapor recovery lines

(N)T92H For Cryogenic Unloading

Thorburn's (N)T92H series is the worlds first dry break full flow coupling used for liquid cryogenic loading/unloading service. A sensational innovation over the poppet style cryogenic coupling which has inherent spillage when disconnected. The (N)T92H coupling has an easy turn action to connect and start the product flow. The full unrestricted flow will dramatically increase loading and unloading productivity of cryogenic liquids. The dry break technology will protect the environment and the operator's safety.

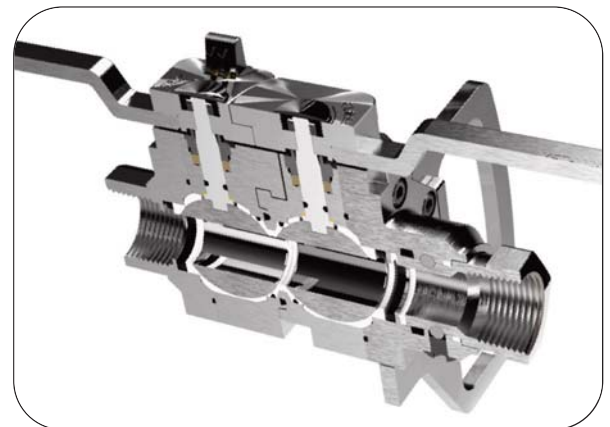
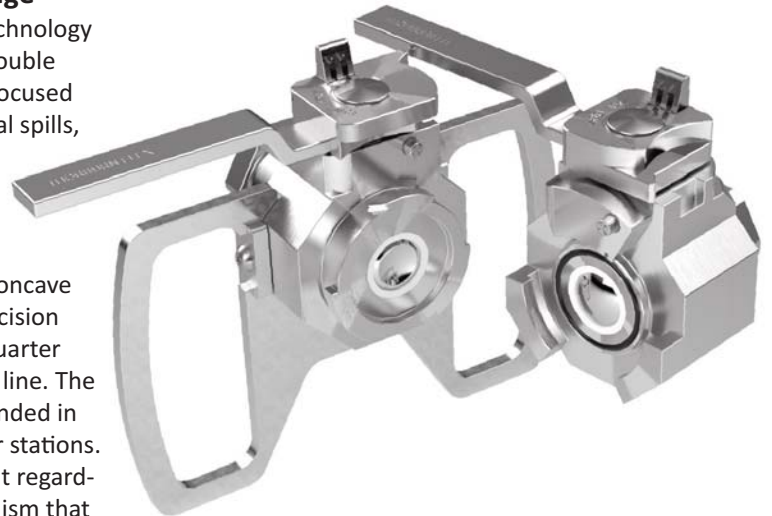

Unrestricted full flow reduces pressure drop during operation



Thorburn's NT92H dry break couplings ideal for cryogenic LNG tank truck loading/unloading. Available with tank truck & railcar flanges

(N)T92H Built In Safety Features

Thorburn Flex (N)T92H is a dry break, zero leak, quick coupling, with mating convex and concave ball valves on each side of the coupling. The (N)T92H unique design features provide up to five levels of independent safety mechanisms to prevent spills and accidental release of dangerous contaminants in the environment. The safety features are based on a combination of locking mechanisms that prevent wrong operation of the coupling by allowing only the preset sequential operation.



- **Ball Valve Zero Gap System** (Convex (male end) & Concave (female end)) prevents hazardous chemical loss during disconnection.
- **Valve Handle Locking System** locks the handle in the off position to safeguard against accidental opening when disconnected.
- **Safety Locking Mechanism** incorporates a Valve Handle Safety Locking Pin to prevent accidental openings.
- **The Locking Pin** is guided by the Valve Handle on the male end coupler.

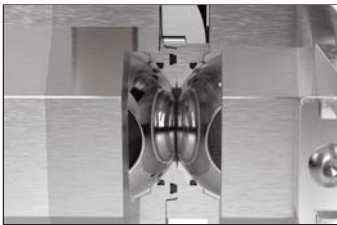

Ball Valve "Zero Gap" System



Valve Handle Locking System



Safety Locking Mechanism



Locking Pin

(N)T92H Performance Characteristics

| Adapter/Coupler Size | | End Size | | Spillage | Maximum Emissions | Flow Rate | | Max. Working Pressure (min. 4-1 Safety) | | Weight | | | | Temperature | | | |
|----------------------|----|----------|--------|----------|-------------------|-----------|-------|--|-----|--------|------|--------|------|-------------|------|-----|-----|
| | | | | | | | | | | Male | | Female | | Min | | Max | |
| in | mm | in | DIN | cc | ppm | GPM | l/min | psi | bar | lb | kg | lb | kg | °F | °C | °F | °C |
| 1 | 25 | 3/4, 1 | 20, 25 | < 0.1 | < 25 | 60 | 227 | 3000 | 207 | 4.02 | 1.82 | 4.23 | 1.92 | -459 | -273 | 400 | 204 |
| 2 | 50 | 1 1/2, 2 | 40, 50 | < 0.2 | < 25 | 180 | 681 | 1800 | 124 | 17.45 | 7.92 | 17.44 | 7.91 | -459 | -273 | 400 | 204 |
| 3 | 80 | 3 | 80 | < 1 | < 25 | 350 | 1325 | 1000 | 69 | 33.70 | 15.2 | 30.65 | 13.9 | -459 | -273 | 400 | 204 |

Problematic Quick Disconnect Coupling Technologies



Cam & Groove Type = Spillage



Ordinary Ball Valves Added = Spillage



Traditional Poppet Valves = Spillage

Cam and Groove type couplings are incapable of avoiding spillage and vapor leakage upon disconnection. They are prone to accidental disconnects, which can be expensive and extremely hazardous.

Ordinary Ball Valves, added to quick couplings to shut off the flow, allow trapped liquid between the hose and the adapter to flow freely on to your plants floor or your employees hands upon disconnection.

Traditional two-way poppet valve style dry break couplings by its very design are predisposed to spills because of the unavoidable liquid that is trapped in the gap between the coupler poppet valve and the adapter poppet valve upon disconnection.

(N)T92H Sealing Technology

Cavity Filler - Prevents flow accumulation between ball valve and coupling body. Reduces spillage when disconnecting and prevents solids from being trapped between the rotating ball valves.

Ball Valve Seal - Flexible arch shaped ball valve seal provides constant sealing pressure and compensates for machining tolerances.

Spring Enhanced O-Ring Seal - Puts constant pressure around the stem and eliminates leaks through the valve handle stem.

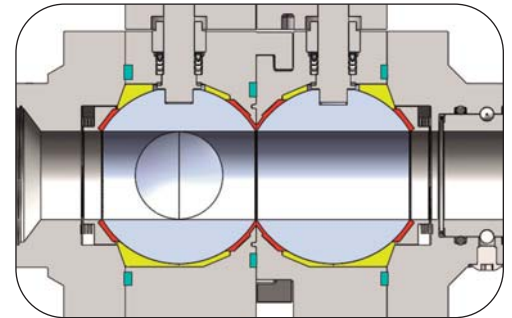

Cavity Filler



Ball Valve Seal

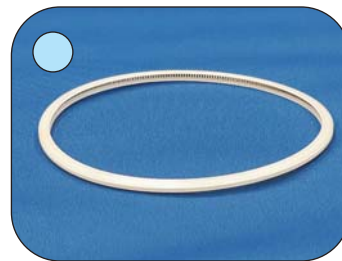

Spring Enhanced O-ring Seal

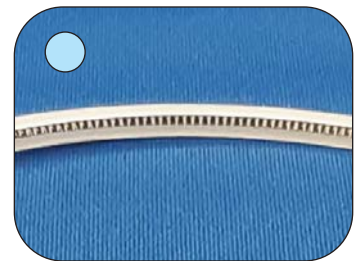

Detail of The Spring in the O-ring Seal

(N)T92H Easy to Operate Dry Break Solution

The (N)T92H coupling has an easy turn action to connect and start the product flow. The valves will not open until both coupling halves are connected properly. The coupling halves are first aligned and then connected with a push, followed by a quarter turn. There are no threads to damage by over tightening and no failure prone cam and groove latch connections to secure. The coupling halves are independent “shut off” ball valves that are controlled manually by rotating the valve handles in a specific sequence.



Align coupling halves



Push together & turn 90°



Coupling connected & locked

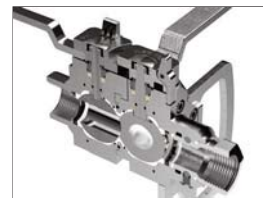

Open male end valve

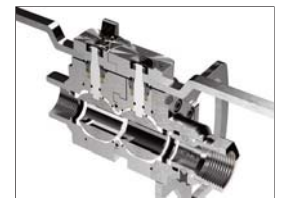

Open female end valve

The (N)T92H can only be disconnected when both the valves are shut off in sequence; female end valve first and then male end valve second. This ensures zero spillage and protects against accidental disconnection.

How To Order (N)T92H Series Dry Break High Pressure Quick Couplings

| Model | Valve Size | Type | Body Material (Wetted Parts) | End Size | 1st End | 2nd End | Seal | Options |
|----------------|---|---|---|---|---|--|----------------------------|---|
| (N)T92H | 16 | 0 | S6 | 32 | 1 | 1 | 1 | DC |
| | 16 = 1" (DN 25) 32 = 2" (DN 50) 48 = 3" (DN 80) | C = Coupler (Socket) N = Plug (Nipple) | S6=SA 479 type 316SS, EN1.4404 S5=SA 564 type 630 EN1.4548 H16=Hastelloy SB574 type C276 EN2.4819 | 12 = 3/4" (DN 20) 16 = 1" (DN 25) 24 = 1 1/2" (DN 40) 32 = 2" (DN 50) 48 = 3" (DN 80) | 1=FNPT 2=FBSP 3=O-Seal 4=SCH 40 Butt Weld 5=SCH 80 Butt Weld 6=ANSI 150# Flange 7=ANSI 300# Flange 8=ANSI 600# Flange 9=PN10 Flange 10=PN16 Flange 11=PN25 Flange 12=PN40 Flange | 13=Sanitary Flange 14=Tank Truck Flange XX=Specify YY=Specify | 1=UMHW 2=PTFE 3=PEEK | H = Handle DC = Dust Cap XX = Specify |

Camlock Quick Couplings



What is a Camlock Quick Coupling?

A camlock coupling, also called a cam and groove coupling, is used to connect two hoses and / or pipes together in a variety of industries, so that a commodity from one can be transferred to the other. They're easy to use, requiring no tools to connect and disconnect the two halves of the couplings and they replace the traditional time-consuming methods of some other types of hose or pipe connections. This, together with their cost effectiveness makes them the most popular coupling in the world.

Typically camlocks are used in every industry, such as manufacturing, agriculture, oil, gas, chemical, pharmaceutical and within military applications. They are an extremely versatile product, and because there are no threads when connecting the coupling halves together, there are no issues with them becoming damaged or dirty. Therefore camlock couplings are very suitable for dirty environments. The system is especially well suited to a situation where frequent changes of hoses are required, such as for petroleum, and industrial chemical trucks.

How does a camlock quick coupling work?

The assembly consists of a male groove adapter and a female coupler. To connect and disconnect:

1. Extend the handles on the coupler outwards and place the correct size male adapter into the female coupler.

2. Close both handles at the same time until the two halves are firmly fixed together.
3. Closing both handles at the same time ensures that the grooved adapter is pulled down consistently onto the seal making a leak proof assembly for the safe transfer of liquids
4. Reverse the process to disconnect the fitting first making sure that the hose assembly has been de-pressurized.

How to measure the dimension of camlocks?

Measuring a metallic camlock fitting is reasonably easy. For instance, if the hose tail, male or female thread is 2", then the camlock coupling would be known as a 2" camlock coupling.

Polypropylene is slightly different. There is no international standard and different manufacturers have different head sizes. In the ½" size, the body is actually ¾" but it's the thread (or hose tail) that is ½". There are also some anomalies in the 1 ¼" sized systems.

With most cam couplings, measure the Outside Diameter (OD) of the adapter head or the Inside Diameter (ID) of the coupler. This will identify the fitting size, as depicted in the images below.



Measuring ID of coupler



Measuring OD of adapter

How do I choose the right camlock coupling?

When specifying a fitting, there are seven fields of information required. The acronym for this is STAMPED, which stands for:

- S** = Size
- T** = Temperature
- A** = Application
- M** = Material (or media being used)
- P** = Pressure rating required
- E** = End fittings & connections (thread type)
- D** = Delivery (any extras, such as material certs)

Camlock Quick Couplings

To what standard are camlocks manufactured?

The standard for cam & groove couplings is based on the US military specification Mil-C-27487 now superseded by A-A-59326D. The original specification was replaced by the new standard, but still guaranteed the interchangeability of couplings designed to the same specification. The Mil-C-27487 specified the casting methods, materials, dimensions, tolerances, pressure ratings, and inspection procedures.

European standard

The European standard EN 14420-7 was approved by CEN in September 2004 and was applied to cam and groove couplings manufactured to the American military standard, as outlined above. This American standard does not apply to the hose connection side, but only to the coupling side.

Camlock fittings produced to EN 14420-7 are interchangeable with those produced to the original MIL-C-27487 standard, but differ in terms of hose tail design, thread, and part number. A flat thread seal has been added to the female threaded parts and a smooth hose shank complying with EN 14420-7/DIN 2828 has been added for assembly with safety clamps complying with EN 14420-3/DIN 2817.



Design Specifications

Materials: Stainless Steel (SA351 CF8M/SA479 T316) - Carbon Steel (Available upon request)

Pressure: 3" ID - 275 psi (19 bar), 4" & 6" ID - 250 psi (17 bar) 4 to 1 safety factor

Gasket: Buna-N (Standard). Also available in EPDM, FKM & PTFE Encapsulated Rubber (ER)

Temperature: Buna-N, EPDM 121°C (250°F), FKM, PTFE (ER) 99°C (210°F)

Warning: Thorburn's Camlock Couplings are designed for liquid transfer only (not to be used for air, gas or steam transfer systems)



Are camlocks interchangeable?

Between manufacturers, cam and groove couplings are interchangeable with the exception of ½" (12.5mm), 5" and 8". The A-A-59326A Mil Specification does not apply to 5" and 8" cam and groove couplings due to the presence of two versions of cam and groove couplings in today's market.

Thorburn's Guard-Lok™ Technology

Prevents Accidental Opening During Operation

Thorburn's Camlock high pressure coupling series have a mechanism built into the levers which prevent accidental disconnection during operation. The coupling levers lock automatically into the coupler body, in the closed position and stay locked until opened manually. Ideal for applications where vibration is present, hose assemblies are dragged or the coupling could be accidentally opened resulting in disastrous spillage.

Guard-Lok™ Advantages

- Locks shut with one smooth motion
- Levers automatically lock to the body when closed
- Prevents accidental disconnection and loss of fluids during operation
- Effortless operation and simple to unlock
- Simple streamlined design does not require loose parts, clips or springs

Camlock Gaskets



Features

- All wetted parts PTFE
- Suitable for most brands of Camlocks
- Easy to replace
- Various materials available
(refer to chemical resistance charts, page 147)

Applications

- Camlock Couplings

Thorburn's Camlock Gaskets fit in the grooves of the female camlock or cam and groove couplings. The pressure of the fitting pushes against the gasket to create a tight seal. Our gaskets are designed to provide a touch seal and can be used safely within the food, petrochemical, and pharmaceutical industries. With an elastomer core and FEP/PFA exterior, the seals are perfect for chemical resistance. Our encapsulated gaskets have a non-stick finish, allowing for easier insertion and leak-free service. Standard material is Nitrile Buna and EPDM, PTFE, FKM, PTFE Buna and PTFE FKM are also available.

Buna Nitrile Type Gaskets

| Part Number | Size | | Material (Standard) | Minimum Temperature | | Maximum Temperature | |
|-------------|-------|-----|---------------------|---------------------|-----|---------------------|----|
| | in | mm | | °F | °C | °F | °C |
| 12TCFG-D | 3/4 | 19 | Nitrile Buna | -40 | -40 | 93 | 34 |
| 16TCFG-D | 1 | 25 | Nitrile Buna | -40 | -40 | 93 | 34 |
| 20TCFG-D | 1 1/4 | 32 | Nitrile Buna | -40 | -40 | 93 | 34 |
| 24TCFG-D | 1 1/2 | 38 | Nitrile Buna | -40 | -40 | 93 | 34 |
| 32TCFG-D | 2 | 51 | Nitrile Buna | -40 | -40 | 93 | 34 |
| 40TCFG-D | 2 1/2 | 64 | Nitrile Buna | -40 | -40 | 93 | 34 |
| 48TCFG-D | 3 | 76 | Nitrile Buna | -40 | -40 | 93 | 34 |
| 64TCFG-D | 4 | 102 | Nitrile Buna | -40 | -40 | 93 | 34 |
| 80TCFG-D | 5 | 127 | Nitrile Buna | -40 | -40 | 93 | 34 |
| 96TCFG-D | 6 | 152 | Nitrile Buna | -40 | -40 | 93 | 34 |

EPDM Type Gaskets

| Part Number | Size | | Material | Minimum Temperature | | Maximum Temperature | |
|-------------|-------|-----|----------|---------------------|-----|---------------------|----|
| | in | mm | | °F | °C | °F | °C |
| 12TCFG-H | 3/4 | 19 | EPDM | -30 | -34 | 149 | 65 |
| 16TCFG-H | 1 | 25 | EPDM | -30 | -34 | 149 | 65 |
| 20TCFG-H | 1 1/4 | 32 | EPDM | -30 | -34 | 149 | 65 |
| 24TCFG-H | 1 1/2 | 38 | EPDM | -30 | -34 | 149 | 65 |
| 32TCFG-H | 2 | 51 | EPDM | -30 | -34 | 149 | 65 |
| 40TCFG-H | 2 1/2 | 64 | EPDM | -30 | -34 | 149 | 65 |
| 48TCFG-H | 3 | 76 | EPDM | -30 | -34 | 149 | 65 |
| 64TCFG-H | 4 | 102 | EPDM | -30 | -34 | 149 | 65 |
| 96TCFG-H | 6 | 152 | EPDM | -30 | -34 | 149 | 65 |

FKM Type Gaskets

| Part Number | Size | | Material | Minimum Temperature | | Maximum Temperature | |
|-------------|-------|-----|----------|---------------------|-----|---------------------|----|
| | in | mm | | °F | °C | °F | °C |
| 12TCFG-I | 3/4 | 19 | FKM | -40 | -40 | 200 | 93 |
| 16TCFG-I | 1 | 25 | FKM | -40 | -40 | 200 | 93 |
| 20TCFG-I | 1 1/4 | 32 | FKM | -40 | -40 | 200 | 93 |
| 24TCFG-I | 1 1/2 | 38 | FKM | -40 | -40 | 200 | 93 |
| 32TCFG-I | 2 | 51 | FKM | -40 | -40 | 200 | 93 |
| 40TCFG-I | 2 1/2 | 64 | FKM | -40 | -40 | 200 | 93 |
| 48TCFG-I | 3 | 76 | FKM | -40 | -40 | 200 | 93 |
| 64TCFG-I | 4 | 102 | FKM | -40 | -40 | 200 | 93 |
| 96TCFG-I | 6 | 152 | FKM | -40 | -40 | 200 | 93 |

PTFE Envelope Type Gaskets

| Part Number | Size | | Material | Minimum Temperature | | Maximum Temperature | |
|-------------|-------|-----|-----------|---------------------|-----|---------------------|----|
| | in | mm | | °F | °C | °F | °C |
| 12TCFG-JD | 3/4 | 19 | PTFE Env. | -40 | -40 | 93 | 34 |
| 16TCFG-JD | 1 | 25 | PTFE Env. | -40 | -40 | 93 | 34 |
| 20TCFG-JD | 1 1/4 | 32 | PTFE Env. | -40 | -40 | 93 | 34 |
| 24TCFG-JD | 1 1/2 | 38 | PTFE Env. | -40 | -40 | 93 | 34 |
| 32TCFG-JD | 2 | 51 | PTFE Env. | -40 | -40 | 93 | 34 |
| 40TCFG-JD | 2 1/2 | 64 | PTFE Env. | -40 | -40 | 93 | 34 |
| 48TCFG-JD | 3 | 76 | PTFE Env. | -40 | -40 | 93 | 34 |
| 64TCFG-JD | 4 | 102 | PTFE Env. | -40 | -40 | 93 | 34 |
| 96TCFG-JD | 6 | 152 | PTFE Env. | -40 | -40 | 93 | 34 |

PTFE-FKM Envelope Type Gaskets

| Part Number | Size | | Material | Minimum Temperature | | Maximum Temperature | |
|-------------|-------|-----|---------------|---------------------|-----|---------------------|----|
| | in | mm | | °F | °C | °F | °C |
| 12TCFG-JI | 3/4 | 19 | PTFE/FKM Env. | -40 | -40 | 200 | 93 |
| 16TCFG-JI | 1 | 25 | PTFE/FKM Env. | -40 | -40 | 200 | 93 |
| 20TCFG-JI | 1 1/4 | 32 | PTFE/FKM Env. | -40 | -40 | 200 | 93 |
| 24TCFG-JI | 1 1/2 | 38 | PTFE/FKM Env. | -40 | -40 | 200 | 93 |
| 32TCFG-JI | 2 | 51 | PTFE/FKM Env. | -40 | -40 | 200 | 93 |
| 40TCFG-JI | 2 1/2 | 64 | PTFE/FKM Env. | -40 | -40 | 200 | 93 |
| 48TCFG-JI | 3 | 76 | PTFE/FKM Env. | -40 | -40 | 200 | 93 |
| 64TCFG-JI | 4 | 102 | PTFE/FKM Env. | -40 | -40 | 200 | 93 |
| 96TCFG-JI | 6 | 152 | PTFE/FKM Env. | -40 | -40 | 200 | 93 |

Thorburn “VS” Metal To Metal Sealing Couplings



Specifications

Pressure Ratings: Thorburn VS Couplings comply with ANSI code B31.3 for pressure piping. Working pressure ratings are rated at ambient temperature and based on a 4 to 1 safety factor. All Thorburn’s Vacuseal coupling components are available with controlled surface finishes to meet the requirements of high purity systems.

Temperature Ratings:

Fittings: Stainless Steel 316, 316L, 316L VAR, 316L VIM/VAR - 1000°F (537°C)

Gaskets: High-Purity Nickel - 600°F (315°C)

Silver plated Stainless Steel: 1000°F (537°C)

Dimensions: are for reference only and are subject to change. Tube ends conform to the dimensional requirements of ASTM A269.

Plating: Female Nuts are silver plated with an enhanced plating process. Avoid aggressive chemical processes used for cleaning, electropolishing and passivation that will remove plating. Removal or damage to plating will cause threads to gall, damaging fitting components and preventing a proper seal.

Testing: Vacuseal products are rated to a Helium leak rate of 1×10^{-9} STD cc/sec.

Internal Surface Finishes: Vacuseal coupling components are available with controlled surface finishes and electropolished internal surfaces.

Applications

- Tool Hook-Up
- Valve Manifold Boxes
- Gas Cabinets
- Fluid and Gas Handling

Thorburn’s VS Series Couplings are metal-to-metal sealing solutions with leak-free service from vacuum to positive pressure and are designed for applications requiring high purity conditions. When assembled, the toroid face forms a leak-tight metal-to-metal connection in vacuum or positive pressure conditions. Vacuseal couplings are manufactured from 316LSS material and are ideally suited for process control or fluid and gas handling applications.

Features

- **Torque gasket:** used to seal damaged toroids and guard against loosening of components due to thermocycling and vibration.
- **Non-rotational female nuts:** used to prevent transmission of torque during make-up and minimizes twisting of components.
- **Anti-galling female nuts:** used to ensure consistent make-up without plating or lubrication.
- **High purity glands:** manufactured from nickel and Hastelloy c-22. Used in extremely corrosive applications.

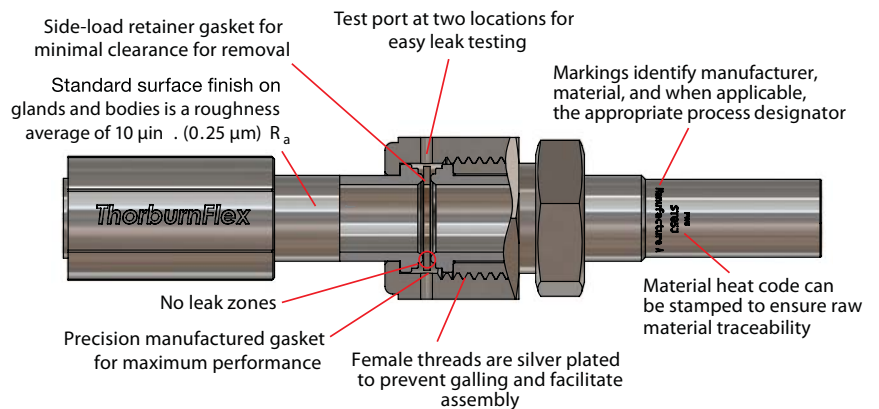

Benefits

- Compact Design allows for system miniaturization and close coupled spacing
- Marked heat codes on each wetted component for material traceability
- Enhanced female nut silver plating promotes consistent easy assembly
- All wetted surfaces meet stringent ultra high purity system requirements
- Thorburn gaskets promote sealing of damaged toroids

Typical Thorburn VS Coupling Assembly

The seal on a VS coupling assembly is made when the metal gasket is compressed by two beads during the engagement of a male nut or body hex and a female nut.

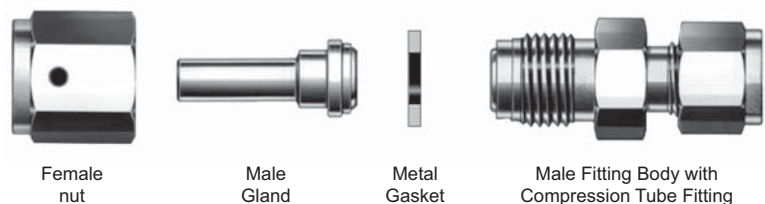

Understanding Flanges



What is a flange?

A flange is a method of connecting pipes, valves, pumps and other equipment to form a piping system. It also provides easy access for cleaning, inspection or modification. Flanges are usually welded or screwed. Flanged joints are made by bolting together two flanges with a gasket between them to provide a seal. When fastened to the pipe, a flange may also be a plate or ring to shape a rim at the end of a pipe.

How are flanges classified?

A lot of common flange standards are to be found around the globe. These are designed to have standardized dimensions to allow easy interchangeability and functionality. ASA / ASME (USA), PN / DIN (EU), BS10 (British / Australian), and JIS / KS (Japanese / Korean) are general world standards. For this catalogue we will focus on ASME and PN type flanges only.

ASME flanges

ASME flanges are classified as per ASME B16.5 standard. The pressure rating of flanges range from 150# to 2500#. The term "lb", "class" and "#" are used interchangeably to designate the pressure rating of the flange. The fact is that 150 lb has no relation to 150 psi and neither does the 300 or 600 lb correlate to 300 or 600 psi pressure ratings. For example, the maximum pressure for a Class 150 flange is 285 psi. Pressure rating of the flange depends on the material (A105, stainless, nickel alloy etc.), the heat treating condition and pressure "class".

The standard includes flanges with rating class designations 150, 300, 400, 600, 900, 1500, and 2500 in sizes NPS 1/2 through NPS 24, with requirements given in both metric and US units. The Standard is limited to flanges and flanged fittings made from cast or forged materials, and blind flanges and certain reducing flanges made from cast, forged, or plate materials. Also included in this Standard are requirements and recommendations regarding flange bolting, flange gaskets, and flange joints.

PN flanges

PN is an acronym for "Pressure Nominale". The PN is used as a prefix to the pressure rating of the Flanges. For instance, a Flat Flange PN16 is designed to operate in pressures up to 16 bar. Following international flange standards such as ISO 7005-1 or DIN 2501, PN10, PN16, PN25, and PN40 specify both pressure class in pressure bars and metric flange dimensions that use the metric measuring system. Flanges developed to ANSI, AWWA, ASA or old British specifications measured in inches will not necessarily fit with the specification of flanges.

PN ratings do not provide a proportional relationship between different PN numbers, whereas class numbers do. Class numbers are therefore recommended before PN ratings.

Types of flanges

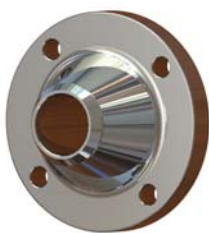

Weld-Neck



Slip-On



Socket Weld



Lap-Joint



Threaded



Blind

Sanitary Flange Clamp Fittings



Sanitary flange clamp fitting installed

What is a sanitary flange clamp fitting?

The food, beverage, and biopharmaceutical industries depend on a number of components to transport products during their manufacturing processes. Items such as unprocessed milk, wort for beer, wine and even medicines need to move from point A to point B during the manufacturing process.

Ordinary flanges cannot be used in this process because stainless steel allows for small pockets and can easily suffer nicks and scratches. These flaws may often be microscopic, but they are still large enough to collect and breed impurities.

Sanitary flange clamp fittings do not carry the same kind of risk as they are polished to an almost flawless finish, reducing the likelihood of these flaws ever developing.

Sanitary flange clamp fittings are extremely versatile to make connections between a large variety of endpoints with different types of adapters such as, Male/Female NPT (National Pipe Thread), end caps, and butt welds. Sanitary flange fittings can also be assembled in different ways to connect different sections of process lines with varying sizes and numerous piping layout configurations.

Dimensions and Sizing

- Size is determined by the OD of the tubing and **NOT** the diameter of the ferrule flange.
- For smaller OD tubing (1/2" & 3/4") and (1" & 1 1/2"), ferrule sizes are combined for each pair.
- Compatible sizes can be joined directly, but different OD tubes will affect flow (always use the larger gasket size).

| Tube OD | Flange OD | Clamp Size |
|---------|-----------|------------|
| in | in | in |
| 1/2 | 0.98 | 3/4 |
| 3/4 | 0.98 | 3/4 |
| 1 | 1.98 | 1/2 |
| 1 1/2 | 1.98 | 1/2 |
| 2 | 2.52 | 2 |
| 2 1/2 | 3.05 | 2 1/2 |
| 3 | 3.58 | 3 |
| 4 | 4.68 | 4 |

Determining the Correct Clamp Size

Clamp size is determined by the outside diameter (OD) of the tubing. This is important because the sanitary flange, which follows a standard, is approximately 1/2" larger than the tubing. A 1.5" Clamp fitting, will have a flange that is 1.984" (almost 2" on a tape measure). If the flange measurement is used and a 2" clamp is ordered, the newly arrived fitting will be a 1/2" too large.

Smaller OD tubing has a similar point of confusion. The 1/2" and 3/4" tubes both share the 3/4" clamp ferrule (0.984" flange), and the same for the 1" and 1.5" tubes which share the 1.5" clamp ferrule (1.984" flange). Two clamp sizes for 4 different fittings and as a result, two pairs of different sized tubing are compatible and can be connected together.

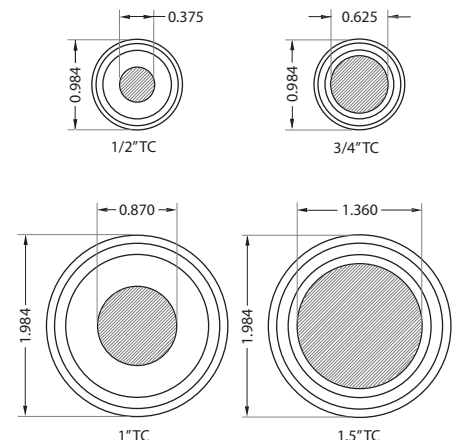

Sanitary Clamp Fittings

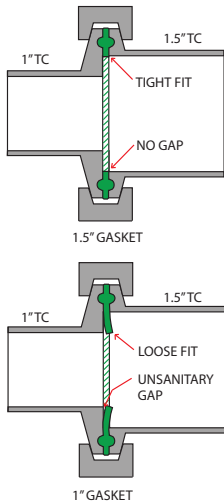

Guide to the Joining and Gasket Selection for Compatible Sizes

Since directly joining each pair of smaller compatible sizes is possible, it will have an effect on the material flowing through the tubing. The different sized tubing will behave just like an end cap reducer, but without the need for a reducer. On larger tubing (2"+) a reducer to transition sizes is required. An end cap reducer, or a concentric/eccentric reducer would suffice, given that both reducers are tapered to allow a more gradual transition between sizes. The smaller compatible sizes also have concentric/eccentric reducers that avoid the abrupt size change.

Gaskets are an important consideration. On larger tubing (2"+), using appropriately sized gaskets when clamped, have minimal intrusion into the flow of material. However, this is not the case when joining a larger tube OD directly to a smaller tube OD of a compatible clamp size. The correct gasket will be sized to the larger of the two tubes. For example, when joining a 1.5" tube to a 1" tube, if a 1" gasket is used, there is a risk of unsanitary conditions around the unclamped section of a 1" gasket loosely held against the face of the 1.5" tube flange. The correct gasket choice is a 1.5" gasket. Similarly when combining 1/2" and 3/4" tubing, it should be joined by a 3/4" gasket. The only time a 1/2" or a 1" gasket are used is when you are combining two 1/2" or two 1" OD tubes, respectively.

Clamp Style Selection

Thorburn's Sanitary Clamp Fitting has three main types: 1) 2-segment (single hinge). 2) 2-segment (double hinge). 3) High pressure bolted no hinge version.



The single hinge design is the most popular, and is considered the most cost-effective for most applications. The double hinge design is much more flexible and is easier to install in tight spaces than the single hinge which may not be able to be installed.

The high pressure bolted version is not hinged, but a bolted design. The bolts are kept from rotating during installation by a shoulder that is part of the clamp casting. They are held together using a lock washer and brass nut; brass is chosen because it is naturally resistant to galling and seizing on stainless steel bolts. These are more suited to a permanent or semi-permanent application where frequent service is not needed or high pressure safety supersedes ease of service.

Clamp Pressure Ratings (PSI)

| Size | Single Hinge (13MHHM) | | Double Hinge (13MHHM-DP) | | High Pressure (13MHP) | | Max Torque |
|-------|-----------------------|-------|--------------------------|-------|-----------------------|-------|------------|
| | 70°F | 250°F | 70°F | 250°F | 70°F | 250°F | |
| 3/4 | 1500 | 1200 | 1500 | 1200 | 1500 | 1200 | 130 in LBf |
| 1 1/2 | 500 | 250 | 500 | 250 | 1500 | 1200 | 130 in LBf |
| 2 | 450 | 250 | 450 | 250 | 1000 | 800 | 130 in LBf |
| 2 1/2 | 400 | 200 | 400 | 200 | 1000 | 800 | 130 in LBf |
| 3 | 350 | 150 | 350 | 150 | 1000 | 800 | 130 in LBf |
| 4 | 200 | 125 | 200 | 125 | 800 | 600 | 200 in LBf |
| 6 | 150 | 75 | - | - | 300 | 200 | 200 in LBf |
| 8 | 100 | 50 | - | - | 250 | 150 | 200 in LBf |
| 10 | 40 | 30 | - | - | 200 | 125 | 200 in LBf |
| 12 | 30 | 25 | - | - | 150 | 100 | 200 in LBf |

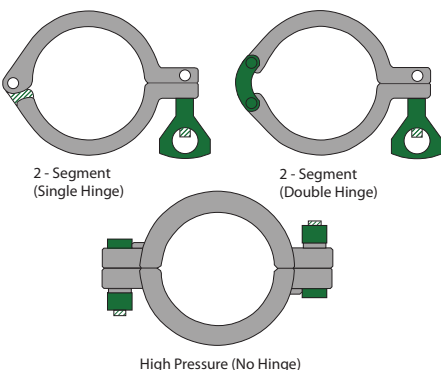

Sanitary Clamp Fittings

Single Hinge Pin Heavy Duty Sanitary Clamp

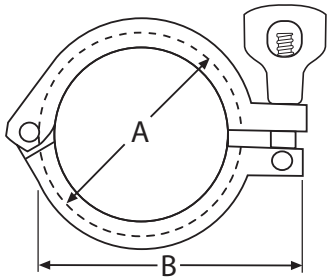

| Part Number | Tube OD Size | | A | | B | |
|-------------|--------------|-----|------|-----|------|-----|
| | in | DIN | in | mm | in | mm |
| S12SHC-S6 | 3/4 | 20 | 1.1 | 28 | 2.3 | 59 |
| S24SHC-S6 | 1 1/2 | 40 | 2.1 | 54 | 3.3 | 83 |
| S32SHC-S6 | 2 | 50 | 2.6 | 67 | 3.8 | 96 |
| S40SHC-S6 | 2 1/2 | 65 | 3.2 | 81 | 4.3 | 109 |
| S48SHC-S6 | 3 | 80 | 3.7 | 94 | 4.8 | 122 |
| S56SHC-S6 | 3 1/2 | 90 | 4.3 | 109 | 5.7 | 144 |
| S64SHC-S6 | 4 | 100 | 4.8 | 122 | 5.9 | 151 |
| S72SHC-S6 | 4 1/2 | 115 | 5.2 | 133 | 7.0 | 178 |
| S80SHC-S6 | 5 | 125 | 5.8 | 148 | 7.1 | 180 |
| S96SHC-S6 | 6 | 150 | 6.7 | 170 | 8.5 | 217 |
| S128SHC-S6 | 8 | 200 | 8.7 | 221 | 11.5 | 291 |
| S160SHC-S6 | 10 | 250 | 10.7 | 271 | 12.7 | 322 |
| S192SHC-S6 | 12 | 300 | 12.7 | 323 | 15.8 | 402 |

Double Hinge Pin Heavy Duty Sanitary Clamp

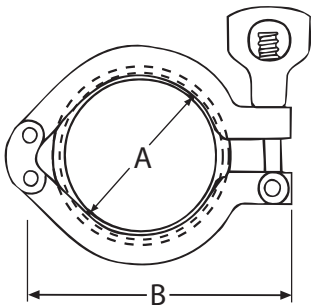

| Part Number | Tube OD Size | | A | | B | |
|-------------|--------------|-----|-----|-----|------|-----|
| | in | DIN | in | mm | in | mm |
| S24DHC-S6 | 1 1/2 | 40 | 2.1 | 54 | 3.3 | 85 |
| S32DHC-S6 | 2 | 50 | 2.6 | 67 | 3.8 | 97 |
| S40DHC-S6 | 2 1/2 | 65 | 3.2 | 81 | 4.4 | 113 |
| S48DHC-S6 | 3 | 80 | 3.7 | 94 | 5.1 | 130 |
| S56DHC-S6 | 3 1/2 | 90 | 4.3 | 109 | 5.7 | 144 |
| S64DHC-S6 | 4 | 100 | 4.8 | 122 | 6.2 | 158 |
| S72DHC-S6 | 4 1/2 | 115 | 5.2 | 133 | 7.0 | 178 |
| S96DHC-S6 | 6 | 150 | 6.7 | 170 | 8.0 | 204 |
| S128DHC-S6 | 8 | 200 | 8.7 | 221 | 10.2 | 260 |

Sanitary Clamp Fittings

3-Piece Segmented Sanitary Clamp

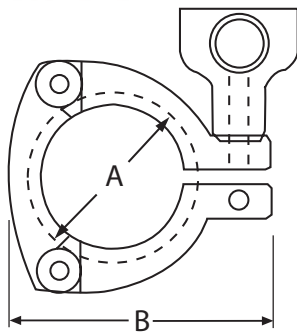

| Part Number | Tube OD Size | | A | | B | |
|-------------|--------------|-----|-----|-----|-----|-----|
| | in | DIN | in | mm | in | mm |
| S24P3C-S6 | 1 1/2 | 40 | 2.1 | 54 | 3.2 | 80 |
| S32P3C-S6 | 2 | 50 | 2.7 | 68 | 3.7 | 94 |
| S40P3C-S6 | 2 1/2 | 65 | 3.2 | 81 | 4.3 | 109 |
| S48P3C-S6 | 3 | 80 | 3.7 | 94 | 5.0 | 126 |
| S64P3C-S6 | 4 | 100 | 4.8 | 122 | 6.1 | 154 |

High Pressure Double Bolted Sanitary Clamp

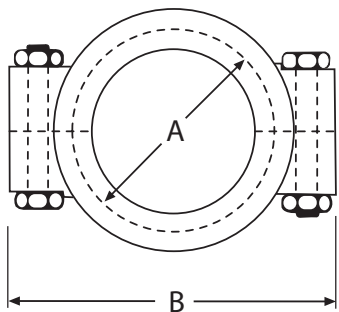

| Part Number | Tube OD Size | | A | | B | |
|-------------|--------------|-----|-----|-----|-----|-----|
| | in | DIN | in | mm | in | mm |
| S24BC-S6 | 1 1/2 | 40 | 2.0 | 52 | 4.0 | 102 |
| S32BC-S6 | 2 | 50 | 2.6 | 66 | 4.5 | 114 |
| S40BC-S6 | 2 1/2 | 65 | 3.1 | 79 | 5.0 | 127 |
| S48BC-S6 | 3 | 80 | 3.7 | 93 | 5.5 | 140 |
| S64BC-S6 | 4 | 100 | 4.8 | 121 | 6.5 | 165 |
| S96BC-S6 | 6 | 150 | 6.7 | 170 | 8.5 | 216 |

Coupling Identification

This section lists the origin and coupling style found in each country. Brief descriptions and dimensional data follows each coupling style. There are five coupling systems generally used for hydraulic connections today. They are identified geographically or by country as:

- North American
- British
- French
- German
- Japanese

North American Thread Types

Iron Pipe Thread Abbreviations

N = National | **P** = Pipe | **S** = Straight Thread | **T** = Tapered Thread | **F** = Fuels | **M** = Mechanical Joint

NPTF

National Pipe Tapered thread for Fuels (NPTF) is a dryseal thread. It is used for both male and female ends. The NPTF male will mate with the NPTF, NPSF, or NPSM female.

The NPTF male has tapered threads and a 30° inverted seat. The NPTF female has tapered threads and no seat. The seal takes place by deformation of the threads. The NPSM female has straight threads and a 30° inverted seat. The seal takes place on the 30° seat.

The NPTF connector is similar to, but not interchangeable with, the BSPT connector. The thread pitch is different in most sizes. Also, the thread angle is 60° instead of the 55° angle found on BSPT threads.

NPSF

National Pipe Straight thread for Fuels (NPSF) is sometimes used for female ends and properly mates with the NPTF male end. However, SAE recommends the NPTF thread in preference to the NPSF for female ends.

NPSM

National Pipe Straight thread for Mechanical joint (NPSM) is used on the female swivel nut of iron pipe swivel adapters. The leak-resistant joint is not made by the sealing fit of threads, but by a tapered seat in the coupling end.

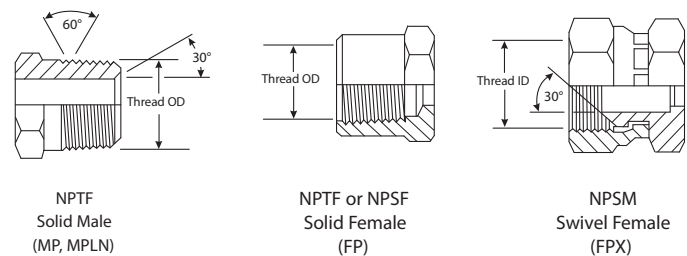

| Dash Size | Nominal Size | | No. Threads per inch | Female Thread I.D. | | Male Thread O.D. | | Recommended Steel Torque* |
|-----------|--------------|----|----------------------|--------------------|----|------------------|----|---------------------------|
| | in | mm | | in | mm | in | mm | |
| -02 | 1/8 | 3 | 27 | 23/64 | 9 | 13/32 | 25 | 20 |
| -04 | 1/4 | 6 | 18 | 15/32 | 12 | 35/64 | 14 | 25 |
| -06 | 3/8 | 10 | 18 | 19/32 | 15 | 43/64 | 17 | 35 |
| -08 | 1/2 | 12 | 14 | 3/4 | 19 | 27/32 | 21 | 45 |
| -12 | 3/4 | 20 | 14 | 61/64 | 24 | 1 1/16 | 27 | 55 |
| -16 | 1 | 25 | 11 1/2 | 1 13/64 | 31 | 1 5/16 | 33 | 65 |
| -20 | 1 1/4 | 30 | 11 1/2 | 1 17/32 | 39 | 1 43/64 | 42 | 80 |
| -24 | 1 1/2 | 40 | 11 1/2 | 1 25/32 | 45 | 1 29/32 | 48 | 95 |
| -32 | 2 | 50 | 11 1/2 | 2 1/4 | 57 | 2 3/8 | 60 | 120 |

***Notes:**

1. Torque values can vary considerably depending on thread condition. Use only enough torque to achieve adequate sealing.
2. With female straight or parallel pipe threads (NPSM), maximum values are 50% of those listed in the table.
3. If thread sealant is used, maximum values shown should be decreased by 25 %.

North American Thread Types

NPT

(National Pipe Thread Tapered) also known as ANSI/ASME B1.20.1 Pipe Threads, General Purpose, can connect with a NPTF or NPT female end. The angle between the taper and the axis of the pipe is 1° 47' 24" (1.7899°). It is similar to the NPTF in all areas except for the following: There is no 30° inverted seat. The thread root and crest is sharp "V"-shaped with minimum truncation. PTFE tape or sealing compound is required for a leak-free seal.

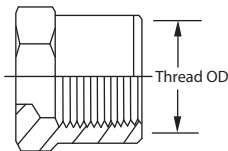
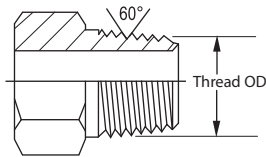

| Dash Size | Nominal Size | | No. Threads per inch | Female Thread I.D. | | Male Thread O.D. | | Steel Torque Recommendation | |
|-----------|--------------|----|----------------------|--------------------|----|------------------|----|-----------------------------|--|
| | in | mm | | in | mm | in | mm | ft/lb | |
| -02 | 1/8 | 3 | 27 | 23/64 | 9 | 13/32 | 25 | 20 | |
| -04 | 1/4 | 6 | 18 | 15/32 | 12 | 35/64 | 14 | 25 | |
| -06 | 3/8 | 10 | 18 | 19/32 | 15 | 43/64 | 17 | 35 | |
| -08 | 1/2 | 12 | 14 | 3/4 | 19 | 27/32 | 21 | 45 | |
| -12 | 3/4 | 20 | 14 | 61/64 | 24 | 1 1/16 | 27 | 55 | |
| -16 | 1 | 25 | 11 1/2 | 1 13/64 | 31 | 1 5/16 | 33 | 65 | |
| -20 | 1 1/4 | 30 | 11 1/2 | 1 17/32 | 39 | 1 43/64 | 42 | 80 | |
| -24 | 1 1/2 | 40 | 11 1/2 | 1 25/32 | 45 | 1 29/32 | 48 | 95 | |
| -32 | 2 | 50 | 11 1/2 | 2 1/4 | 57 | 2 3/8 | 60 | 120 | |

JIC 37° Flare

The Society of Automotive Engineers (SAE) specifies a 37° angle flare or seat be used with high pressure hydraulic tubing. These are commonly called JIC couplings. The JIC 37° flare male will mate with a JIC female only. The JIC male has straight threads and a 37° flare seat. The JIC female has straight threads and a 37° flare seat. The seal is made on the 37° flare seat. Some sizes have the same threads as the SAE 45° flare. Carefully measure the seat angle to differentiate.

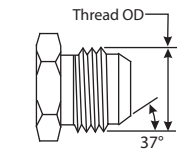

JIC 37° Male (MJ)

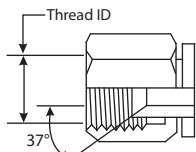

JIC 37° Flare Female (FJX)

| Dash Size | Nominal Size | | Threads Size | Female Thread I.D. | | Male Thread O.D. | | Steel Torque Recommendation (Ft. Lbs.) | |
|-----------|--------------|----|--------------|--------------------|----|------------------|----|--|-----|
| | in | mm | | in | mm | in | mm | Min | Max |
| -02 | 1/8 | 3 | 5/16-24 | 17/64 | 7 | 5/16 | 8 | - | - |
| -03 | 3/16 | 5 | 3/8-24 | 21/64 | 8 | 3/8 | 10 | - | - |
| -04 | 1/4 | 6 | 7/16-20 | 25/64 | 10 | 7/16 | 11 | 10 | 11 |
| -05 | 5/16 | 8 | 1/2-20 | 29/64 | 12 | 1/2 | 12 | 13 | 15 |
| -06 | 3/8 | 10 | 9/16-18 | 1/2 | 12 | 9/16 | 14 | 17 | 19 |
| -08 | 1/2 | 12 | 3/4-16 | 11/16 | 17 | 3/4 | 20 | 34 | 38 |
| -10 | 5/8 | 16 | 7/8-14 | 13/16 | 21 | 7/8 | 22 | 50 | 56 |
| -12 | 3/4 | 20 | 1 1/16-12 | 31/32 | 25 | 1 1/16 | 27 | 70 | 78 |
| -14 | 7/8 | 22 | 1 3/16-12 | 1 7/64 | 28 | 1 3/16 | 30 | - | - |
| -16 | 1 | 25 | 1 5/16-12 | 1 15/64 | 31 | 1 5/16 | 33 | 94 | 104 |
| -20 | 1 1/4 | 30 | 1 5/8-12 | 1 35/64 | 39 | 1 5/8 | 41 | 124 | 138 |
| -24 | 1 1/2 | 40 | 1 7/8-12 | 1 51/64 | 46 | 1 7/8 | 48 | 156 | 173 |
| -32 | 2 | 50 | 2 1/2-12 | 2 27/64 | 62 | 2 1/2 | 64 | 219 | 243 |

North American Thread Types

SAE 45° Flare

A term usually applied to fittings having a 45° angle flare or seat. Soft copper tubing is generally used in such applications as it is easily flared to the 45° angle. These are for low-pressure applications—such as for fuel lines and refrigerant lines.

The SAE 45° flare male will mate with an SAE 45° flare female only or a dual seat JIC/SAE 45°. * The SAE male has straight threads and a 45° flare seat. The SAE female has straight threads and a 45° flare seat. The seal is made on the 45° flare seat.

Some sizes have the same threads as the SAE 37° flare. Carefully measure the seat angle to differentiate.

*Note: Some C5, C5E and Lock-On couplings may have dual machined seats (both 37° and 45° seats).

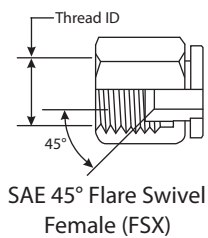
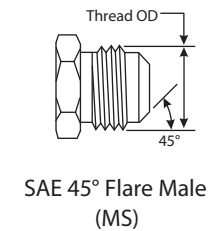

| Dash Size | Nominal Size | | Threads Size | Female Thread I.D. | | Male Thread O.D. | | Steel Torque Recommendation (Ft. Lbs.) | |
|-----------|--------------|----|--------------|--------------------|----|------------------|----|--|-----|
| | in | mm | | in | mm | in | mm | Min | Max |
| -02 | 1/8 | 3 | 5/16-24 | 17/64 | 7 | 5/16 | 8 | - | - |
| -03 | 3/16 | 5 | 3/8-24 | 21/64 | 8 | 3/8 | 10 | - | - |
| -04 | 1/4 | 6 | 7/16-20 | 25/64 | 10 | 7/16 | 11 | 11 | 14 |
| -05 | 5/16 | 8 | 1/2-20 | 29/64 | 12 | 1/2 | 12 | 14 | 18 |
| -06 | 3/8 | 10 | 9/16-18 | 1/2 | 12 | 9/16 | 14 | 18 | 22 |
| -08 | 1/2 | 12 | 3/4-16 | 11/16 | 17 | 3/4 | 20 | 36 | 45 |
| -10 | 5/8 | 16 | 7/8-14 | 13/16 | 21 | 7/8 | 22 | 57 | 71 |
| -12 | 3/4 | 20 | 1 1/16-12 | 31/32 | 25 | 1 1/16 | 27 | 79 | 99 |

Special Power Steering Thread End

| Dash Size | Nominal Size | | Threads Size | Female Thread I.D. | | Male Thread O.D. | |
|-----------|--------------|----|--------------|--------------------|----|------------------|----|
| | in | mm | | in | mm | in | mm |
| -06 | 3/8 | 10 | 11/16-18 | 5/8 | 16 | 11/16 | 17 |

North American Thread Types

O-Ring Boss

The O-ring boss male will mate with an O-ring boss female only. The female is generally found on ports. The male has straight threads, a sealing face and an O-ring. The female has straight threads and a sealing face. The seal is made at the O-ring on the male and the sealing face on the female.

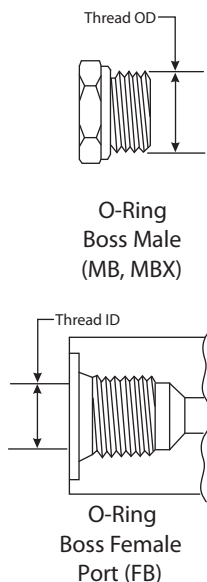

| Dash Size | Nominal Size | | Threads Size | Female Thread I.D. | | Male Thread O.D. | | O-Ring | |
|-----------|--------------|----|--------------|--------------------|----|------------------|----|---------|-------|
| | in | mm | | in | mm | in | mm | ID (in) | DESCR |
| -02 | 1/8 | 3 | 5/16-24 | 17/64 | 7 | 5/16 | 8 | 0.239 | - |
| -03 | 3/16 | 5 | 3/8-24 | 21/64 | 8 | 3/8 | 10 | 0.301 | 30R |
| -04 | 1/4 | 6 | 7/16-20 | 25/64 | 10 | 7/16 | 11 | 0.351 | 40R |
| -05 | 5/16 | 8 | 1/2-20 | 29/64 | 12 | 1/2 | 12 | 0.414 | 50R |
| -06 | 3/8 | 10 | 9/16-18 | 1/2 | 12 | 9/16 | 14 | 0.468 | 60R |
| -08 | 1/2 | 12 | 3/4-16 | 11/16 | 17 | 3/4 | 20 | 0.644 | 80R |
| -10 | 5/8 | 16 | 7/8-14 | 13/16 | 21 | 7/8 | 22 | 0.755 | 100R |
| -12 | 3/4 | 20 | 1 1/16-12 | 31/32 | 25 | 1 1/16 | 27 | 0.924 | 120R |
| -14 | 7/8 | 22 | 1 3/16-12 | 1 7/64 | 28 | 1 3/16 | 30 | 1.048 | 140R |
| -16 | 1 | 25 | 1 5/16-12 | 1 15/64 | 31 | 1 5/16 | 33 | 1.171 | 160R |
| -20 | 1 1/4 | 30 | 1 5/8-12 | 1 35/64 | 40 | 1 5/8 | 41 | 1.475 | 200R |
| -24 | 1 1/2 | 40 | 1 7/8-12 | 1 51/64 | 45 | 1 7/8 | 48 | 1.720 | - |
| -32 | 2 | 50 | 2 1/2-12 | 2 27/64 | 62 | 2 1/2 | 64 | 2.337 | - |

O-Ring Boss Light Duty - SAE J1926-3

| Dash Size | Assembly Torque* +25%-0 ft/lb | Assembly Torque* Max. ft/lb | Assembly Torque* +25%-0 N-m | Assembly Torque* Max. N-m |
|-----------|----------------------------------|--------------------------------|--------------------------------|------------------------------|
| -02 | 6 | 7 | 8 | 10 |
| -03 | 7 | 9 | 10 | 13 |
| -04 | 13 | 17 | 18 | 23 |
| -05 | 18 | 23 | 25 | 31 |
| -06 | 22 | 28 | 30 | 38 |
| -08 | 37 | 46 | 50 | 63 |
| -10 | 44 | 55 | 60 | 75 |
| -12 | 70 | 88 | 95 | 119 |
| -14 | 92 | 115 | 125 | 156 |
| -16 | 111 | 138 | 150 | 188 |
| -20 | 147 | 184 | 200 | 250 |
| -24 | 155 | 193 | 210 | 263 |
| -32 | 221 | 276 | 300 | 375 |
| -40 | 221 | 276 | 300 | 375 |
| -48 | 258 | 322 | 350 | 438 |
| -64 | 258 | 322 | 350 | 438 |

* Values from SAE J2593 - Feb 2015

O-Ring Boss Heavy Duty - SAE J1926-2

| Dash Size | Assembly Torque* +25%-0 ft/lb | Assembly Torque* Max. ft/lb | Assembly Torque* +25%-0 N-m | Assembly Torque* Max. N-m |
|-----------|----------------------------------|--------------------------------|--------------------------------|------------------------------|
| -03 | 7 | 9 | 10 | 13 |
| -04 | 15 | 18 | 20 | 25 |
| -05 | 18 | 23 | 25 | 31 |
| -06 | 26 | 32 | 35 | 44 |
| -08 | 52 | 64 | 70 | 88 |
| -10 | 74 | 92 | 100 | 125 |
| -12 | 125 | 157 | 170 | 213 |
| -14 | 158 | 198 | 215 | 269 |
| -16 | 199 | 249 | 270 | 338 |
| -20 | 210 | 263 | 285 | 356 |
| -24 | 273 | 341 | 370 | 463 |
| -32 | 398 | 497 | 540 | 675 |
| -40 | 398 | 497 | 540 | 675 |
| -48 | 472 | 590 | 640 | 800 |

* Values from SAE J2593 - Feb 2015

North American Thread Types

O-Ring Face Seal SAE J1453

A seal is made when the O-ring in the male contacts the flat face on the female. Couplings are intended for hydraulic systems where elastomeric seals are acceptable to overcome leakage and leak resistance is crucial.

The solid male O-ring face seal fitting will mate with a swivel female O-ring face seal SAE J1453 fitting only. An O-ring rests in the O-ring groove in the male.

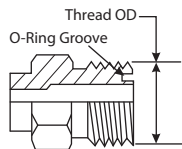

Male Flat-Face O-Ring (MFFOR)

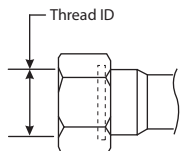

Female Flat-Face O-Ring Swivel (FFORX)

| Dash Size | Nominal Size | | Threads Size | Female Thread I.D. | | Male Thread O.D. | | O-Ring Size |
|-----------|--------------|----|--------------|--------------------|----|------------------|----|-------------|
| | in | mm | | in | mm | in | mm | |
| -04 | 1/4 | 6 | 9/16-18 | 1/2 | 12 | 9/16 | 14 | -011 |
| -06 | 3/8 | 10 | 11/16-16 | 5/8 | 16 | 11/16 | 17 | -012 |
| -08 | 1/2 | 12 | 13/16-16 | 3/4 | 20 | 13/16 | 21 | -014 |
| -10 | 5/8 | 16 | 1-14 | 15/16 | 24 | 1 | 25 | -016 |
| -12 | 3/4 | 20 | 1 3/16-12 | 1 1/8 | 29 | 1 3/16 | 30 | -018 |
| -16 | 1 | 25 | 1 7/16-12 | 1 11/32 | 34 | 1 7/16 | 37 | -021 |
| -20 | 1 1/4 | 30 | 1 11/16-12 | 1 19/32 | 40 | 1 11/16 | 43 | -025 |
| -24 | 1 1/2 | 40 | 2-12 | 1 29/32 | 48 | 2 | 50 | -029 |
| -32 | 2 | 50 | 2 1/2-12 | - | - | - | - | - |

SAE Inverted Flare

The SAE 45° inverted flare male will mate with an SAE 42° inverted flare female only. The male has straight threads and a 45° inverted flare. The female has straight threads and a 42° inverted flare. The seal is made on the 45° flare seat on the male and the 42° flare seat on the female.

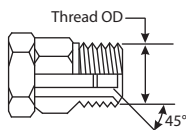

SAE Inverted Flare Swivel Male (MIX)

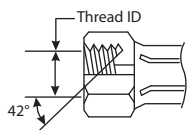

SAE Inverted Flare Solid Female

| Dash Size | Nominal Size | | Threads Size | Female Thread I.D. | | Male Thread O.D. | |
|-----------|--------------|----|--------------|--------------------|----|------------------|----|
| | in | mm | | in | mm | in | mm |
| -02 | 1/8 | 3 | 5/16-28 | 9/32 | 7 | 5/16 | 8 |
| -03 | 3/16 | 5 | 3/8-24 | 21/64 | 8 | 3/8 | 10 |
| -04 | 1/4 | 6 | 7/16-24 | 25/64 | 10 | 7/16 | 11 |
| -05 | 5/16 | 8 | 1/2-20 | 29/64 | 12 | 1/2 | 12 |
| -06 | 3/8 | 10 | 5/8-18 | 37/64 | 15 | 5/8 | 16 |
| -07 | 7/16 | 11 | 11/16-18 | 5/8 | 16 | 11/16 | 17 |
| -08 | 1/2 | 12 | 3/4-18 | 45/64 | 18 | 3/4 | 20 |
| -10 | 5/8 | 16 | 7/8-18 | 13/16 | 21 | 7/8 | 22 |
| -12 | 3/4 | 20 | 1 1/16-16 | 1 | 25 | 1 1/16 | 27 |

North American Thread Types

O-Ring Flange—SAE J518 (Code 61 & Code 62)

The SAE code 61 and Code 62 4-Bolt Split Flange. Code 61 is considered the “standard” series and Code 62 is the “6000 psi” series. Their basic design is the same, but for the higher pressure Code 62 connection, the bolt hole spacing and flanged head diameters are larger and the flange head thicker (“C” dimension in picture). These connectors are used the world over in fluid power systems, usually as a connection to pumps and motors. There are three exceptions.

1. The -10 size, which is common outside of North America, is not an SAE standard size (generally found on Komatsu equipment).

All Komatsu flanges are the same as SAE code 61 except for the -10 size.

2. Caterpillar flanges, which are the same flange O.D. as SAE Code 62, have a thicker flange head (“C” dimension in Table).

3. Poclain flanges, which are completely different from SAE flanges.

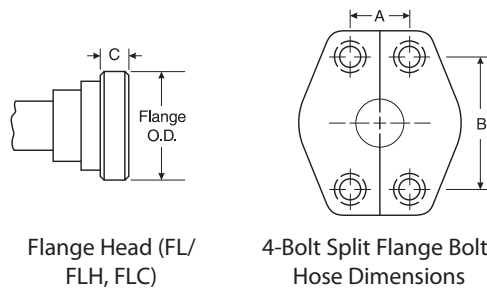

Flange Head (FL/
FLH, FLC)

4-Bolt Split Flange Bolt
Hose Dimensions

| Dash Size | Nominal Flange Size | Code 61 (FL) | | | | Code 62 (FLH) | | | | Caterpillar Code 62 (FLC) | | | |
|-----------|---------------------|--------------|------|------|------|---------------|------|------|------|---------------------------|------|------|------|
| | | Flange O.D. | A | B | C | Flange O.D. | A | B | C | Flange O.D. | A | B | C |
| | | in | in | in | in | in | in | in | in | in | in | in | in |
| -08 | 1/2 | 1.19 | 0.67 | 1.50 | 0.27 | 1.25 | 0.72 | 1.59 | 0.31 | - | - | - | - |
| -10 | 5/8 | 1.35 | - | - | 0.27 | - | - | - | - | - | - | - | - |
| -12 | 3/4 | 1.50 | 0.88 | 1.88 | 0.27 | 1.63 | 0.94 | 2.00 | 0.35 | 1.63 | 0.94 | 2.00 | 0.56 |
| -16 | 1 | 1.75 | 1.03 | 2.06 | 0.32 | 1.88 | 1.09 | 2.25 | 0.38 | 1.88 | 1.09 | 2.25 | 0.56 |
| -20 | 1 1/4 | 2.00 | 1.19 | 2.31 | 0.32 | 2.13 | 1.25 | 2.63 | 0.41 | 2.13 | 1.25 | 2.63 | 0.56 |
| -24 | 1 1/2 | 2.38 | 1.41 | 2.75 | 0.32 | 2.50 | 1.44 | 3.13 | 0.50 | 2.50 | 1.44 | 3.13 | 0.56 |
| -32 | 2 | 2.81 | 1.69 | 3.06 | 0.38 | 3.13 | 1.75 | 3.81 | 0.50 | 3.13 | 1.75 | 3.81 | 0.56 |
| -40 | 2 1/2 | 3.31 | 2.00 | 3.50 | 0.38 | - | - | - | - | - | - | - | - |
| -48 | 3 | 4.00 | 2.44 | 4.19 | 0.38 | - | - | - | - | - | - | - | - |
| -56 | 3 1/2 | 4.50 | 2.75 | 4.75 | 0.42 | - | - | - | - | - | - | - | - |
| -64 | 4 | 5.00 | 3.06 | 5.13 | 0.44 | - | - | - | - | - | - | - | - |
| -80 | 5 | 6.00 | 3.63 | 6.00 | 0.44 | - | - | - | - | - | - | - | - |

Foreign Thread Types

Identifying Foreign Couplings

If you can identify the country of origin of the equipment you are working with, it is easy to identify the coupling style. Simply find the appropriate country in the following pages and locate the particular coupling in the table that follows.

Foreign Thread Types – British

It is a common misconception that all foreign threads are metric. This is not always the case. There are two common thread forms: Metric and Whitworth (BSP). The country of origin and the proper nomenclature for each is listed below.

British Standard Pipe Parallel

Popular couplings have British Standard Pipe (BSP) threads, also known as Whitworth threads. These can be parallel threads (BSPP) with a 30° inverted flare or tapered threads (BSPT), with a 30° inverted flare. Port connections are usually made with BSPP threads and a soft metal cutting ring for sealing. The BSPP (parallel) male will mate with a BSPOR (parallel) female or a female port. The BSPP male has straight threads and a 30° seat. The BSPOR female has straight threads, a 30° seat, and O-ring. The female port has straight threads and a spotface. The seal on the port is made with an O-ring or soft metal washer on the male. The BSPP (parallel) connector is similar to, but not interchangeable with, the NPSM connector. The thread pitch is different in most sizes, and the thread angle is 55° instead of the 60° angle found on NPSM threads.

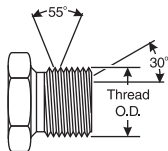

BSPP Male
(MBSPP)

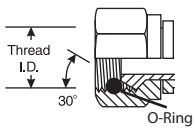

BSPOR Female
(FBSPORX)

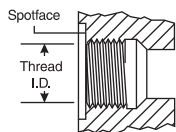

BSPOR Female Port

| Dash Size | Nominal Size | | Threads Size | Female Thread I.D. | | Male Thread O.D. | | Steel Torque Recommendation (Ft. Lbs.) | |
|-----------|--------------|----|--------------|--------------------|----|------------------|----|--|-----|
| | in | mm | | in | mm | in | mm | Min | Max |
| -02 | 1/8 | 3 | 1/8-28 | 11/32 | 9 | 3/8 | 10 | 7 | 9 |
| -04 | 1/4 | 6 | 1/4-19 | 15/32 | 12 | 17/32 | 13 | 11 | 18 |
| -06 | 3/8 | 10 | 3/8-19 | 19/32 | 15 | 21/32 | 17 | 19 | 28 |
| -08 | 1/2 | 12 | 1/2-14 | 3/4 | 20 | 13/16 | 21 | 30 | 36 |
| -10 | 5/8 | 16 | 5/8-14 | 13/16 | 21 | 29/32 | 23 | 37 | 44 |
| -12 | 3/4 | 20 | 3/4-14 | 31/32 | 25 | 1 1/32 | 26 | 50 | 60 |
| -16 | 1 | 25 | 1-11 | 1 7/32 | 31 | 1 11/32 | 34 | 79 | 95 |
| -20 | 1 1/4 | 30 | 1 1/4-11 | 1 17/32 | 39 | 1 21/32 | 42 | 127 | 152 |
| -24 | 1 1/2 | 40 | 1 1/2-11 | 1 25/32 | 45 | 1 7/8 | 48 | 167 | 190 |
| -32 | 2 | 50 | 2-11 | 2 7/32 | 56 | 2 11/32 | 60 | 262 | 314 |

Foreign Thread Types – British

British Flat-Face Seal

A seal is made when the O-ring in the male contacts the flat face on the female. These couplings are intended for hydraulic systems where elastomeric seals are acceptable to overcome leakage and leak resistance is crucial. The solid male British O-ring face seal fitting will mate with a swivel female British O-ring face seal fitting only. An O-ring rests in the O-ring groove in the male.

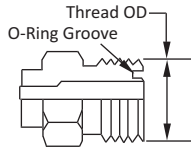

Male British Flat-Face (MBFF)

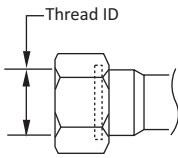

Female British Flat-Face (FBFF)

| Dash Size | Nominal Size | | Threads Size | Female Thread I.D. | | Male Thread O.D. | | Steel Torque Recommendation (Ft. Lbs.) | |
|-----------|--------------|----|--------------|--------------------|----|------------------|----|--|-----|
| | in | mm | | in | mm | in | mm | Min | Max |
| -06 | 3/8 | 10 | 3/8-19 | 19/32 | 15 | 21/32 | 17 | 18 | 20 |
| -08 | 1/2 | 12 | 1/2-14 | 3/4 | 20 | 13/16 | 21 | 32 | 40 |
| -10 | 5/8 | 16 | 5/8-14 | - | - | - | - | - | - |
| -12 | 3/4 | 20 | 3/4-14 | 31/32 | 25 | 1 1/32 | 26 | 65 | 80 |
| -16 | 1 | 25 | 1-11 | - | - | - | - | - | - |

British Standard Pipe Tapered

The BSPT (tapered) male will mate with a BSPT (tapered) female, or a BSPOR (parallel) female. The BSPT male has tapered threads. When mating with either the BSPT (tapered) female or the BSPOR (parallel) female port, the seal is made on the threads. The BSPT connector is similar to, but not interchangeable with, the NPTF connector. The thread pitch is different in most cases, and the thread angle is 55° instead of the 60° angle found on NPTF threads.

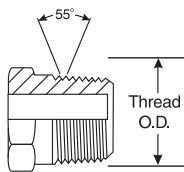

BSPT Male

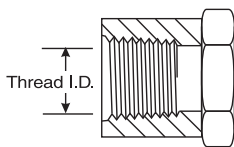

BSPT Female (FBSPT)

| Dash Size | Nominal Size | | Threads Size | Female Thread I.D. | | Male Thread O.D. | | Steel Torque Recommendation (Ft. Lbs.) | |
|-----------|--------------|----|--------------|--------------------|----|------------------|----|--|-----|
| | in | mm | | in | mm | in | mm | Min | Max |
| -02 | 1/8 | 3 | 1/8-24 | 11/32 | 9 | 3/8 | 10 | 7 | 9 |
| -04 | 1/4 | 6 | 1/4-19 | 15/32 | 12 | 17/32 | 13 | 11 | 18 |
| -06 | 3/8 | 10 | 3/8-19 | 19/32 | 15 | 21/32 | 17 | 19 | 28 |
| -08 | 1/2 | 12 | 1/2-14 | 3/4 | 20 | 13/16 | 21 | 30 | 36 |
| -10 | 5/8 | 16 | 5/8-14 | 13/16 | 21 | 29/32 | 23 | 37 | 44 |
| -12 | 3/4 | 20 | 3/4 | 31/32 | 25 | 1 1/32 | 26 | 50 | 60 |
| -16 | 1 | 25 | 14 | 1 7/32 | 31 | 1 11/32 | 34 | 79 | 95 |
| -20 | 1 1/4 | 30 | 1-11 | 1 17/32 | 39 | 1 21/32 | 42 | 127 | 152 |
| -24 | 1 1/2 | 40 | 1 1/4-11 | 1 25/32 | 45 | 1 7/8 | 48 | 167 | 190 |
| -32 | 2 | 50 | 2-11 | 2 7/32 | 56 | 2 11/32 | 60 | 262 | 314 |

Foreign Thread Types – German DIN (Deutsche Industriale Norme)

Popular couplings are German DIN (Deutsche Industriale Norme). A coupling referred to as “metric” usually means a DIN coupling.

DIN 24° Cone

The DIN 24° cone male will mate with any of the females shown. The male has a 24° seat, straight metric threads, and a recessed counterbore which matches the tube O.D. of the coupling used with it. The mating female is a 24° cone with O-ring, a metric tube fitting or a universal 24° and 60° cone. There is a light and heavy series DIN coupling. Identification is made by measuring both the thread size and tube O.D. (The heavy series has a smaller tube O.D. but a thicker wall section than the light.) When measuring the flare angle with the seat angle gauge, use the 12° gauge. The seat angle gauge measures the angle from the connector centerline.

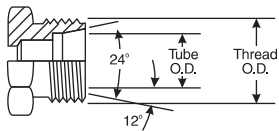

Male 24° Cone, DIN 2353 (MDL/MDH)

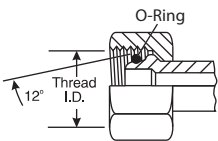

Female 24° Cone with O-Ring (FDLORX/FDHORX)

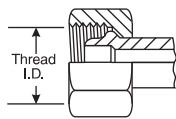

Female Universal 24° and 60° Cone (FDLX/FDHX)

| Dash Size | Female Thread I.D. | Male Thread O.D. | Tube O.D. Light Series | Tube O.D. Heavy Series | Steel Torque Recommendation (Ft. Lbs.) | |
|-----------|--------------------|------------------|------------------------|------------------------|--|-----|
| | mm | mm | mm | mm | Min | Max |
| M12x1.5 | 10.5 | 12.0 | 6 | - | 7 | 15 |
| M14x1.5 | 12.5 | 14.0 | 8 | - | 15 | 26 |
| M16x1.5 | 14.5 | 16.0 | 10 | 8 | 18 | 30 |
| M18x1.5 | 16.5 | 18.0 | 12 | 10 | 22 | 33 |
| M20x1.5 | 18.5 | 20.0 | 14 | 12 | 26 | 37 |
| M22x1.5 | 20.5 | 22.0 | 15 | 14 | 30 | 52 |
| M24x1.5 | 22.5 | 24.0 | - | 16 | 30 | 52 |
| M26x1.5 | 24.5 | 26.0 | 18 | - | 44 | 74 |
| M30x2.0 | 28.0 | 30.0 | 22 | 20 | 59 | 89 |
| M36x2.0 | 34.0 | 36.0 | 28 | 25 | 74 | 111 |
| M42x2.0 | 40.0 | 42.0 | - | 30 | 74 | 162 |
| M45x2.0 | 43.0 | 45.0 | 35 | - | 133 | 184 |
| M52x2.0 | 50.0 | 52.0 | 42 | 38 | 148 | 221 |

DIN 60° Cone

The DIN 60° cone male will mate with the female universal 24° or 60° cone connector only. The male has a 60° seat and straight metric threads. The female has a 24° and 60° universal seat and straight metric threads. When measuring the flare angle with the seat angle gauge, use the 30° gauge. The seat angle gauge measures the angle from the connector centerline.

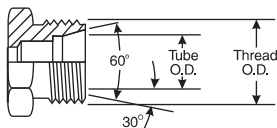

Male 60° Cone, DIN 6711

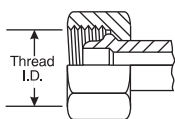

Female Universal 24° and 60° Cone

| Dash Size | Female Thread I.D. | Male Thread O.D. | Tube O.D. | Steel Torque Recommendation (Ft. Lbs.) | |
|-----------|--------------------|------------------|-----------|--|-----|
| | mm | mm | mm | Min | Max |
| M14x1.5 | 12.5 | 14 | 8 | 15 | 26 |
| M16x1.5 | 14.5 | 16 | 10 | 18 | 30 |
| M18x1.5 | 16.5 | 18 | 12 | 22 | 33 |
| M22x1.5 | 20.5 | 22 | 15 | 30 | 52 |
| M26x1.5 | 24.5 | 26 | 18 | 44 | 74 |
| M30x1.5 | 28.5 | 30 | 22 | 59 | 59 |
| M38x1.5 | 36.5 | 38 | 28 | 74 | 111 |
| M45x1.5 | 43.5 | 45 | 35 | 133 | 184 |
| M52x2.0 | 50.5 | 52 | 42 | 148 | 221 |

Foreign Thread Types – German DIN (Deutsche Industrial Norme)

DIN 3852 Couplings Type A & B (Parallel Threads)

The male DIN 3852 Type A & B couplings will mate with the female DIN coupling shown below. Thorburn offers this thread as an adapter. The male and female type A & B couplings have straight threads. The seal occurs when the ring seal (Type A) or the face seal (Type B) mates with the face of the female port. There are two series of DIN 3852 Type A & B couplings, the light (L) and the heavy (S) series. - Note: Commonly used threads on male metric adapters.

| | | Metric Thread Parallel | | | | | | | | Whitworth Thread Parallel | | | | | | | |
|--------------|-----------|------------------------|-----------|-----|-----|-----------|-----|-----|----------|---------------------------|-----------|-----|-------|-------------|-----|-----|----|
| Series | Tube O.D. | Female End | | | | Male End | | | | Female (BSPOR) | | | | Male (BSPP) | | | |
| | | Thread | Thread ID | A | B | Thread OD | A | B | C | Thread | Thread ID | A | B | Thread OD | A | B | C |
| | | Size | mm | mm | mm | mm | mm | mm | mm | mm | Size | in | mm | mm | in | mm | mm |
| L (Light) | 06 | 10x1.0 | 8.5 | 15 | 1.0 | 10 | 14 | 1.5 | 8 | 1/8-28 | 11/32 | 15 | 1.0 | 3/8 | 14 | 1.5 | 8 |
| | 08 | 12x1.5 | 10.5 | 18 | 1.5 | 12 | 17 | 2.0 | 12 | 1/4-19 | 15/32 | 19 | 1.5 | 1/2 | 17 | 2.0 | 12 |
| | 10 | 14x1.5 | 12.5 | 20 | 1.5 | 14 | 19 | 2.0 | 12 | 1/4-19 | 15/32 | 19 | 1.5 | 1/2 | 19 | 2.0 | 12 |
| | 12 | 16x1.5 | 14.5 | 22 | 1.5 | 16 | 21 | 2.5 | 12 | 3/8-19 | 19/32 | 23 | 2.0 | 21/32 | 21 | 2.5 | 12 |
| | 15 | 18x1.5 | 16.5 | 24 | 2.0 | 18 | 23 | 2.5 | 12 | 1/2-14 | 3/4 | 27 | 2.5 | 13/16 | 23 | 2.5 | 12 |
| | 18 | 22x1.5 | 20.5 | 28 | 2.5 | 22 | 27 | 3.0 | 14 | 1/2-14 | 3/4 | 27 | 2.5 | 13/16 | 27 | 3.0 | 14 |
| | 22 | 26x1.5 | 24.5 | 32 | 2.5 | 26 | 31 | 3.0 | 16 | 3/4-14 | 31/32 | 33 | 2.5 | 1 1/32 | 31 | 3.0 | 16 |
| | 28 | 33x2.0 | 31.5 | 40 | 2.5 | 33 | 39 | 3.0 | 18 | 1-11 | 1 7/32 | 40 | 2.5 | 1 5/16 | 39 | 3.0 | 18 |
| | 35 | 42x2.0 | 40.5 | 50 | 2.5 | 42 | 49 | 3.0 | 20 | 1 1/4-11 | 1 17/32 | 50 | 2.5 | 1 21/32 | 49 | 3.0 | 20 |
| 42 | 48x2.0 | 46.5 | 56 | 2.5 | 48 | 55 | 3.0 | 22 | 1 1/2-11 | 1 25/32 | 56 | 2.5 | 1 7/8 | 55 | 3.0 | 22 | |
| S (Heavy) | 06 | 12x1.5 | 10.5 | 18 | 1.5 | 12 | 17 | 2.0 | 12 | 1/4-19 | 15/32 | 19 | 1.5 | 1/2 | 17 | 2.0 | 12 |
| | 08 | 14x1.5 | 12.5 | 20 | 1.5 | 14 | 19 | 2.0 | 12 | 1/4-19 | 15/32 | 19 | 1.5 | 1/2 | 19 | 2.0 | 12 |
| | 10 | 16x1.5 | 14.5 | 22 | 1.5 | 16 | 21 | 2.5 | 12 | 3/8-19 | 19/32 | 23 | 2.0 | 21/32 | 21 | 2.5 | 12 |
| | 12 | 18x1.5 | 16.5 | 24 | 2.0 | 18 | 23 | 2.5 | 12 | 3/8-19 | 19/32 | 23 | 2.0 | 21/32 | 23 | 2.5 | 12 |
| | 14 | 20x1.5 | 18.5 | 26 | 2.0 | 20 | 25 | 3.0 | 14 | 1/2-14 | 3/4 | 27 | 2.5 | 13/16 | 25 | 3.0 | 14 |
| | 16 | 22x1.5 | 20.5 | 28 | 2.5 | 22 | 27 | 3.0 | 14 | 1/2-14 | 3/4 | 27 | 2.5 | 13/16 | 27 | 3.0 | 14 |
| | 20 | 27x2.0 | 25.5 | 33 | 2.5 | 27 | 32 | 3.0 | 16 | 3/4-14 | 31/32 | 33 | 2.5 | 1 1/32 | 32 | 3.0 | 16 |
| | 25 | 33x2.0 | 31.5 | 40 | 2.5 | 33 | 39 | 3.0 | 18 | 1-11 | 1 7/32 | 40 | 2.5 | 1 5/16 | 39 | 3.0 | 18 |
| | 30 | 42x2.0 | 40.5 | 50 | 2.5 | 42 | 49 | 3.0 | 20 | 1 1/4-11 | 1 17/32 | 50 | 2.5 | 1 21/32 | 49 | 3.0 | 20 |
| 38 | 48x2.0 | 46.5 | 56 | 2.5 | 48 | 55 | 3.0 | 22 | 1 1/2-11 | 1 25/32 | 56 | 2.5 | 1 7/8 | 55 | 3.0 | 22 | |

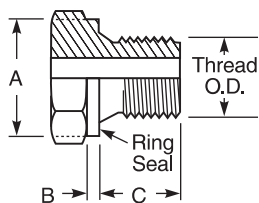

Male Type A

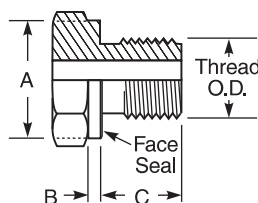

Male Type B

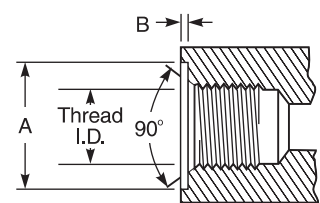

Female Types A & B

Foreign Thread Types – German DIN (Deutsche Industrial Norme)

DIN 3852 Type C Metric and Whitworth Tapered (BSPT) Thread Connectors

The DIN 3852 Type C couplings are available with either metric or Whitworth British thread. The male will mate only with the female as shown. The male and female couplings have tapered threads. The seal takes place on the threads. There are three series of DIN 3852 Type C Couplings: extra light (LL), light (L) and heavy (S).

| | | Metric Tapered Threads | | | | | | Whitworth Tapered Threads | | | | | |
|---------------------|-----------------|------------------------|-------------------|---------|-------------------|---------|---------|---------------------------|-------------------|---------|-------------------|---------|---------|
| Series | Tube O.D. mm | Female | | | Male | | | Female (BSPOR) | | | Male (BSPP) | | |
| | | Thread Size | Thread I.D. mm | A mm | Thread O.D. mm | A mm | B mm | Thread Size | Thread I.D. in | A mm | Thread O.D. in | A mm | B mm |
| | | | | | | | | | | | | | |
| LL (Extra Light) | 04 | 8x1.0 | 6.5 | 5.5 | 8 | 8.40 | 8 | 1/8-28 | 11/32 | 5.5 | 1/8 | 0.392 | 8 |
| | 05 | 8x1.0 | 6.5 | 5.5 | 8 | 8.40 | 8 | 1/8-28 | 11/32 | 5.5 | 1/8 | 0.392 | 8 |
| | 06 | 10x1.0 | 8.5 | 5.5 | 10 | 10.40 | 8 | 1/8-28 | 11/32 | 5.5 | 1/8 | 0.392 | 8 |
| | 08 | 10x1.0 | 8.5 | 5.5 | 10 | 10.40 | 8 | 1/8-28 | 11/32 | 5.5 | 1/8 | 0.392 | 8 |
| L (Light) | 06 | 10x1.0 | 8.5 | 5.5 | 10 | 10.40 | 8 | 1/8-28 | 11/32 | 5.5 | 1/8 | 0.392 | 8 |
| | 08 | 12x1.5 | 10.5 | 8.5 | 12 | 12.53 | 12 | 1/4-19 | 15/32 | 8.5 | 1/4 | 0.532 | 12 |
| | 10 | 14x1.5 | 12.5 | 8.5 | 14 | 14.53 | 12 | 1/4-19 | 15/32 | 8.5 | 1/4 | 0.532 | 12 |
| | 12 | 16x1.5 | 14.5 | 8.5 | 16 | 16.53 | 12 | 3/8-19 | 19/32 | 8.5 | 3/8 | 0.670 | 12 |
| | 15 | 18x1.5 | 16.5 | 8.5 | 18 | 18.53 | 12 | 1/2-14 | 3/4 | 8.5 | 1/2 | 0.839 | 14 |
| | 18 | 22x1.5 | 20.5 | 10.5 | 22 | 22.65 | 14 | 1/2-14 | 3/4 | 10.5 | 1/2 | 0.839 | 14 |
| S (Heavy) | 06 | 12x1.5 | 10.5 | 8.5 | 12 | 12.53 | 12 | 1/4-19 | 15/32 | 8.5 | 1/4 | 0.532 | 12 |
| | 08 | 14x1.5 | 12.5 | 8.5 | 14 | 14.53 | 12 | 1/4-19 | 15/32 | 8.5 | 1/4 | 0.532 | 12 |
| | 10 | 16x1.5 | 14.5 | 8.5 | 16 | 16.53 | 12 | 3/8-19 | 19/32 | 8.5 | 3/8 | 0.670 | 12 |
| | 12 | 18x1.5 | 16.5 | 8.5 | 18 | 18.53 | 12 | 3/8-19 | 19/32 | 8.5 | 3/8 | 0.670 | 12 |
| | 14 | 20x1.5 | 18.5 | 10.5 | 20 | 20.65 | 12 | 1/2-14 | 3/4 | 10.5 | 1/2 | 0.839 | 14 |
| | 16 | 22x1.5 | 20.5 | 10.5 | 22 | 22.65 | 14 | 1/2-14 | 3/4 | 10.5 | 1/2 | 0.839 | 14 |

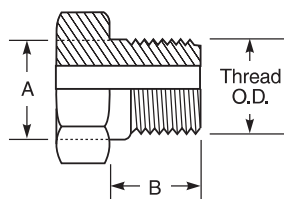

Male

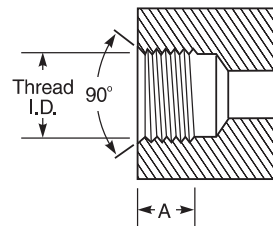

Female

Foreign Thread Types – German DIN (Deutsche Industrial Norme)

DIN 20066 Form R & Form S 4-Bolt Flange

These connections are commonly used in fluid power systems. There are two pressure ratings: Form R, the identical equivalent to North America’s Code 61, is the “standard duty” series; Form S, the identical equivalent to North America’s Code 62, is the “heavy duty” series. The basic design for the two are the same, but in the case of the higher pressure Form S connection, the bolt hole spacing and flanged head diameters are larger. Both metric and inch bolts are used. The female port is an unthreaded hole with four bolt holes in a rectangular pattern around the port. The male consists of a flanged head with a groove for an O-ring, and either captive flange or split flange halves with bolt O-ring, which is compressed between the flanged head and the flat surface surrounding the port. The threaded bolts hold the connection together.

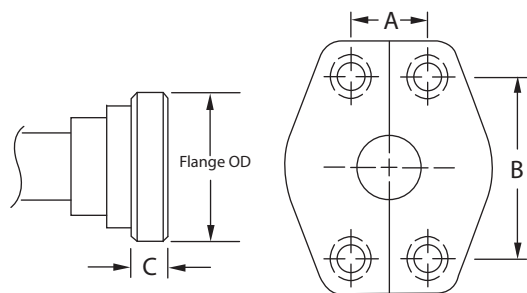

| Nominal Flange Size | Form R | | | | Form S | | | |
|---------------------|-------------|------|------|------|-------------|------|------|------|
| | Flange O.D. | A | B | C | Flange O.D. | A | B | C |
| in | in | in | in | in | in | in | in | in |
| 1/2 | 1.19 | 0.67 | 1.50 | 0.27 | 1.25 | 0.72 | 1.58 | 0.31 |
| 5/8 | 1.35 | - | - | 0.27 | - | - | - | - |
| 3/4 | 1.50 | 0.88 | 1.88 | 0.27 | 1.63 | 0.94 | 2.00 | 0.35 |
| 1 | 1.75 | 1.03 | 2.06 | 0.32 | 1.88 | 1.09 | 2.25 | 0.38 |
| 1 1/4 | 2.00 | 1.19 | 2.31 | 0.32 | 2.13 | 1.25 | 2.63 | 0.41 |
| 1 1/2 | 2.38 | 1.41 | 2.75 | 0.32 | 2.50 | 1.44 | 3.13 | 0.50 |
| 2 | 2.81 | 1.69 | 3.06 | 0.38 | 3.13 | 1.75 | 3.81 | 0.50 |
| 2 3/4 | 3.31 | 2.00 | 3.50 | 0.38 | - | - | - | - |
| 3 | 4.00 | 2.44 | 4.19 | 0.38 | - | - | - | - |
| 3 1/2 | 4.50 | 2.75 | 4.75 | 0.44 | - | - | - | - |
| 4 | 5.00 | 3.06 | 5.13 | 0.44 | - | - | - | - |
| 5 | 6.00 | 3.63 | 6.00 | 0.44 | - | - | - | - |

Metric Stand Pipe Assembly

A metric stand pipe assembly is comprised of three components attached to a male fitting. The components are: a Stand Pipe Tube, Bite Sleeve and Metric Nut. The nut is placed over the Stand Pipe, followed by the Bite Sleeve (see illustration below). For DIN light assemblies, a DIN light metric nut is used. For DIN heavy assemblies, a DIN heavy metric nut is used. The Bite Sleeve and Stand Pipe are selected on the basis of tube O.D.

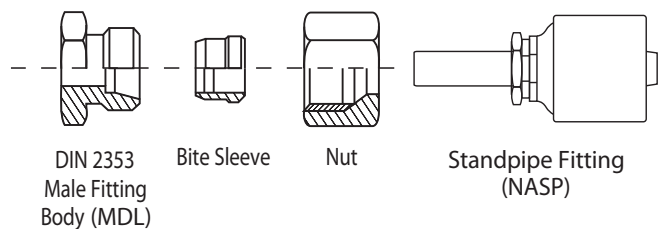

| Metric Stand Pipe DIN Tube I.D. | Bite Sleeve DIN Tube O.D. | Metric Nut Thread | |
|---------------------------------|---------------------------|-------------------|---------|
| | | Light | Heavy |
| mm | mm | | |
| 06 | 6 | M12x1.5 | - |
| 08 | 8 | M14x1.5 | M16x1.5 |
| 10 | 10 | M16x1.5 | M18x1.5 |
| 12 | 12 | M18x1.5 | M20x1.5 |
| 15 | 15 | M22x1.5 | - |
| 16 | 16 | - | M24x1.5 |
| 18 | 18 | M26x1.5 | - |
| 20 | 20 | - | M30x2.0 |
| 22 | 22 | M30x2.0 | - |
| 25 | 25 | - | M36x2.0 |
| 28 | 28 | M36x2.0 | - |
| 30 | 30 | - | M42x2.0 |
| 35 | 35 | M45x2.0 | - |
| 38 | 38 | - | M52x2.0 |
| 42 | 42 | M52x2.0 | - |

Foreign Thread Types – French

Popular couplings are French GAZ. These have a 24° seat and metric threads. These are similar to German DIN couplings, but the threads are different in some sizes. Although both are metric threads, the French use fine threads in all sizes and German DIN couplings use coarse threads in larger sizes.

Metric (Millimetrique & GAZ Series) 24°

The male mates with the female 24° cone or the female tube fitting. The male has a 24° seat and straight metric threads. The female has a 24° seat or a tubing sleeve and straight metric threads. The seal occurs on the 24° taper in the male end. When measuring the flare angle with a seat metric gauge, use a 12° gauge. The seat angle gauge measures the angle from the connector centerline. The Millimetrique Series is used with whole number metric OD tubing and the GAZ Series is used with fractional number metric O.D. pipe size tubing.

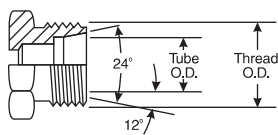

Male 24° Cone

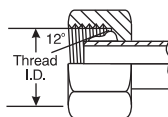

Female 24° Cone

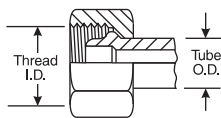

Female Tube Fitting

| Tube O.D. | GAZ Pipe O.D. | Metric Thread Size | Male Thread O.D. | Female Thread O.D. |
|-----------|---------------|--------------------|------------------|--------------------|
| mm | mm | | mm | mm |
| 06 | - | M12x1.0 | 12 | 11 |
| 08 | - | M14x1.5 | 14 | 12.5 |
| 10 | - | M16x1.5 | 16 | 14.5 |
| 12 | - | M18x1.5 | 18 | 16.5 |
| 14 | 13.25 | M20x1.5 | 20 | 18.5 |
| 15 | - | M22x1.5 | 22 | 20.5 |
| 16 | 16.75 | M24x1.5 | 24 | 22.5 |
| 18 | - | M27x1.5 | 27 | 25.5 |
| 22 | 21.25 | M30x1.5 | 30 | 28.5 |
| 25 | - | M33x1.5 | 33 | 31.5 |
| 28 | 26.75 | M36x1.5 | 36 | 34.5 |
| 30 | - | M39x1.5 | 39 | 37.5 |
| 32 | - | M42x1.5 | 42 | 40.5 |
| 35 | 33.50 | M45x1.5 | 45 | 43.5 |
| 38 | - | M48x1.5 | 48 | 46.5 |
| 40 | 42.25 | M52x1.5 | 52 | 50.5 |

GAZ Poclairn 24° Flange

Most port connections are flange connections. French flanges differ from SAE in that they have a lip that protrudes from the flange face. These are called Poclairn style flanges. These high-pressure flanges are usually found on Poclairn equipment. The male flange mates with a female flange or port. The seal is made on the 24° seat.

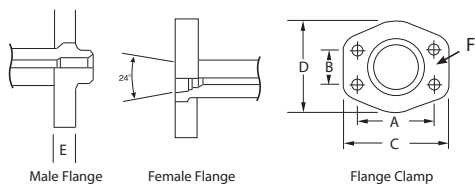

Male Flange

Female Flange

Flange Clamp

| Nominal Size | A | B | C | D | E | F |
|--------------|------|------|------|------|------|------|
| in | in | in | in | in | in | in |
| 1/2 | 1.57 | 0.72 | 2.20 | 1.89 | 0.55 | 0.35 |
| 5/8 | 1.57 | 0.72 | 2.20 | 1.89 | 0.55 | 0.35 |
| 3/4 | 2 | 0.94 | 2.75 | 2.38 | 0.71 | 0.43 |

Foreign Thread Types – Japanese

There are two popular types of coupling styles in Japan, Japanese Industrial Standard and Komatsu. These couplings look similar to Male JIC and Female JIC Swivel couplings. However, there are two major differences: the threads are BSP and the seat angle is only 30° instead of 37° for JIC.

1. Japanese Industrial Standard: Most Japanese equipment uses this type of coupling with a 30° seat and British Standard Pipe Parallel threads. They are not interchangeable with British couplings, since the flare is not inverted.
2. Komatsu: All Komatsu equipment uses couplings with a 30° seat and metric fine threads. All flanges are Code 61 or Code 62, except -10 which utilizes a special Komatsu-style flange that does not conform to SAE standard sizing.

Japanese 30° Flare Parallel Threads

The Japanese 30° flare male connector will mate with a Japanese 30° flare female only. The male and female have straight threads and a 30° seat. The seal is made on the 30° seat. The threads on the Japanese 30° flare connector conform to JIS B 0202, which are the same as the BSPOR threads. Both the British and Japanese connectors have a 30° seat, but they are not interchangeable because the British seat is inverted.

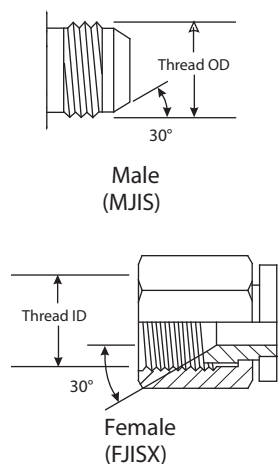

| Dash Size | Nominal Size | | Threads Size | Female Thread I.D. | | Male Thread O.D. | |
|-----------|--------------|----|--------------|--------------------|----|------------------|----|
| | in | mm | | in | mm | in | mm |
| -02 | 1/8 | 3 | 1/8-28 | 11/32 | 9 | 3/8 | 10 |
| -04 | 1/4 | 6 | 1/4-19 | 7/16 | 11 | 17/32 | 13 |
| -06 | 3/8 | 10 | 3/8-19 | 19/32 | 15 | 21/32 | 17 |
| -08 | 1/2 | 12 | 1/2-14 | 3/4 | 20 | 13/16 | 21 |
| -10 | 5/8 | 16 | 5/8-14 | 13/16 | 21 | 29/32 | 23 |
| -12 | 3/4 | 20 | 3/4-14 | 15/16 | 24 | 1 1/32 | 26 |
| -16 | 1 | 25 | 1-11 | 1 13/16 | 46 | 1 15/16 | 49 |
| -20 | 1 1/4 | 30 | 1 1/4-11 | 1 17/32 | 39 | 1 21/32 | 42 |
| -24 | 1 1/2 | 40 | 1 1/2-11 | 1 25/32 | 45 | 1 7/8 | 47 |
| -32 | 2 | 50 | 2-11 | 2 7/32 | 56 | 2 11/32 | 60 |

Japanese Tapered Pipe Thread

The Japanese tapered pipe thread connector is identical to and fully interchangeable with the BSPT (tapered) connector. The Japanese connector does not have a 30° flare and will not mate with the BSPOR female. The threads conform to JIS B 0203, which are the same as BSPT threads. The seal on the Japanese tapered pipe thread connector is made on the threads.

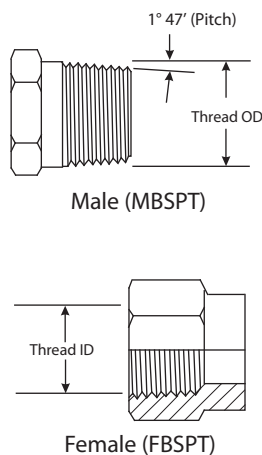

| Dash Size | Nominal Size | | Threads Size | Female Thread I.D. | | Male Thread O.D. | |
|-----------|--------------|----|--------------|--------------------|----|------------------|----|
| | in | mm | | in | mm | in | mm |
| -02 | 1/8 | 3 | 1/8-28 | 11/32 | 9 | 3/8 | 10 |
| -04 | 1/4 | 6 | 1/4-19 | 7/16 | 11 | 17/32 | 13 |
| -06 | 3/8 | 10 | 3/8-19 | 19/32 | 15 | 21/32 | 17 |
| -08 | 1/2 | 12 | 1/2-14 | 3/4 | 20 | 13/16 | 21 |
| -12 | 3/4 | 20 | 3/4-14 | 15/16 | 24 | 1 1/32 | 26 |
| -16 | 1 | 25 | 1-11 | 1 13/16 | 46 | 1 15/32 | 37 |
| -20 | 1 1/4 | 30 | 1 1/4-11 | 1 17/32 | 39 | 1 21/32 | 42 |
| -24 | 1 1/2 | 40 | 1 1/2-11 | 1 25/32 | 45 | 1 7/8 | 48 |
| -32 | 2 | 50 | 2-11 | 2 7/32 | 56 | 1 11/32 | 34 |
| -32 | 2 | 50 | 2-11 | 2 7/32 | 56 | 2 11/32 | 60 |

Foreign Thread Types – Japanese

Komatsu Style 30° Flare Parallel Threads

The Komatsu style 30° flare parallel thread connector is identical to the Japanese 30° flare parallel thread connector, except for the threads. The Komatsu style connector uses metric fine threads which conform to JIS B 0207. Gates identifies these as Komatsu-style by marking the hex nuts with two small notches. The Komatsu style connector seals on the 30° flare.

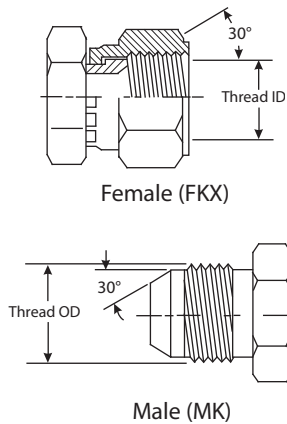

| Dash Size | Nominal Size | | Threads Size | Female Thread I.D. | | Male Thread O.D. | |
|-----------|--------------|----|--------------|--------------------|----|------------------|----|
| | in | mm | | in | mm | in | mm |
| -04 | 1/4 | 6 | M14x1.5 | 0.50 | 12 | 0.55 | 14 |
| -06 | 3/8 | 10 | M18x1.5 | 0.65 | 17 | 0.71 | 18 |
| -08 | 1/2 | 12 | M22x1.5 | 0.81 | 21 | 0.87 | 22 |
| -10 | 5/8 | 16 | M24x1.5 | 0.89 | 23 | 0.94 | 24 |
| -12 | 3/4 | 20 | M30x1.5 | 1.12 | 29 | 1.18 | 30 |
| -16 | 1 | 25 | M33x1.5 | 1.24 | 32 | 1.30 | 33 |
| -20 | 1 1/4 | 30 | M36x1.5 | 1.36 | 35 | 1.42 | 36 |
| -24 | 1 1/2 | 40 | M42x1.5 | 1.59 | 41 | 1.65 | 42 |

Komatsu Style Flange Fitting

The Komatsu style flange fitting is nearly identical to and fully interchangeable with the SAE Code 61 flange fitting. In all sizes, the O-ring dimensions are different. When replacing a Komatsu style flange with an SAE style flange, an SAE style O-ring must always be used.

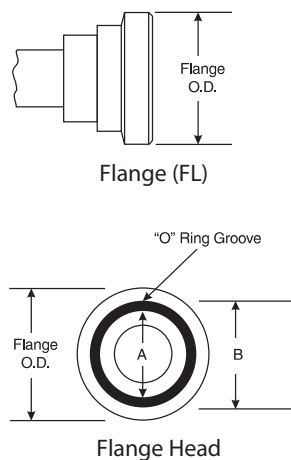

| Dash Size | Nominal Size | | Flange O.D. | A | | B | |
|-----------|--------------|----|-------------|------|----|------|----|
| | in | mm | | in | mm | in | mm |
| -08 | 1/2 | 12 | 1.19 | 0.73 | 19 | 0.98 | 25 |
| -10 | 5/8 | 16 | 1.35 | 0.73 | 19 | 1.10 | 28 |
| -12 | 3/4 | 20 | 1.50 | 0.85 | 22 | 1.22 | 31 |
| -16 | 1 | 25 | 1.75 | 1.12 | 28 | 1.50 | 38 |
| -20 | 1 1/4 | 30 | 2.00 | 1.34 | 34 | 1.73 | 44 |
| -24 | 1 1/2 | 40 | 2.38 | 1.75 | 44 | 2.13 | 54 |
| -32 | 2 | 50 | 2.81 | 2.23 | 57 | 2.56 | 65 |

How To Measure Threads



Use The Pitch Gauge

To determine the number of threads per inch. Or in the case of metric connections, the distance between threads. Place the gauge on the threads until the threads are snug. Match the measurements to the charts. Comparison of gauge and coupling threads against a lit background will assure an accurate reading.

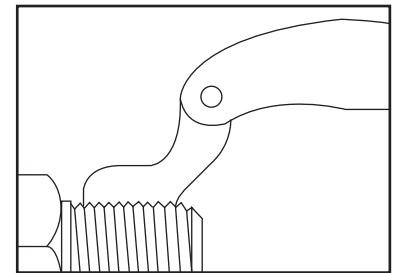

Use Calipers

To measure I.D. and O.D.. Measure the thread diameter at the largest point: O.D. for male threads and I.D. for female threads. Match measurements to charts.

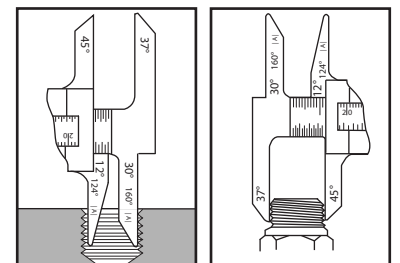

ID

OD

To Measure Sealing Surfaces

Female Connections are normally measured by inserting the gauge into the connection and placing it on the sealing surface. If the centerline and lines of the connection match, the correct angle has been determined.

Male Flare Type Connectors are normally measured by placing the gauge on the sealing surface. If the centerlines of the connection and gauge are parallel, the correct angle has been determined.

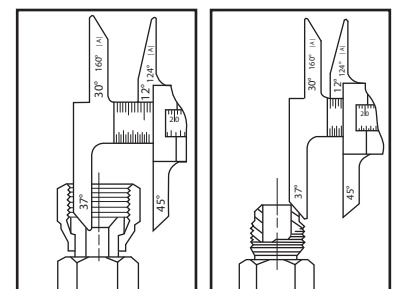

Female

Male

Hose Technical Data

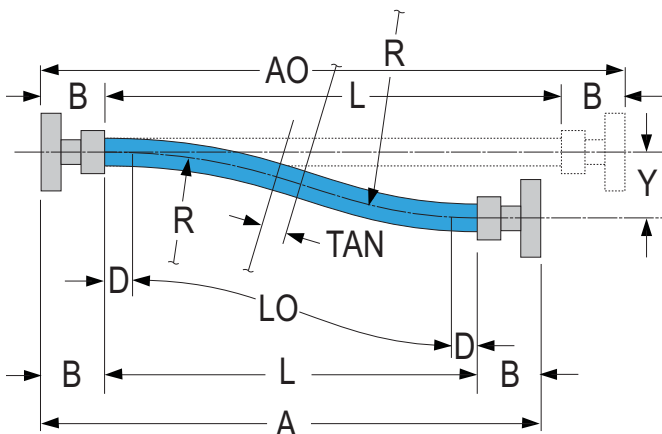

Offset Installation

Hose is installed S-shaped to accommodate offset (Y) between two mating flanges or connecting ends of the piping. To be used for static offset installation not for dynamic movement due to piping thermal expansion or vibration, maximum offset (Y) to be 50% of hose minimum static bend radius (Rs):
 $Y=0.5*Rs$

- A0** = Face to Face dimension for straight (as built) hose assembly
- A** = Face to Face for installation
- B** = Length of end connector
- D** = Outside diameter of the hose
- L** = Total live length of the hose
- L0** = Minimum live length for offset installation
- R** = Bend radius of the offset installation ($R \geq Rs$)
- Rs** = Minimum static bend radius for hose
- Y** = Lateral offset of the installation

$$A = L + 2*B$$

$$L = L0 + 2*D$$

$$L0 = 2*Rs*acos((Rs-Y)/2*Rs)$$

See table below for sample calculated value of L0

| Min. Bend Radius (in) | Y= Offset Installation (in) | | | | | | | | | | | | | | | |
|-----------------------|---|-------|-------|-------|-------|-------|-------|-------|-------|-------|-------|-------|-------|-------|-------|--------|
| | 1/8 | 1/4 | 3/8 | 1/2 | 3/4 | 1 | 1 1/2 | 2 | 3 | 4 | 5 | 6 | 8 | 10 | 20 | 30 |
| | L0= Calculated Minimum Length for Offset Bending (in) | | | | | | | | | | | | | | | |
| 2 | 1.00 | 1.42 | 1.75 | 2.02 | 2.49 | 2.89 | 3.58 | | | | | | | | | |
| 4 | 1.42 | 2.01 | 2.46 | 2.84 | 3.49 | 4.04 | 4.98 | 5.78 | | | | | | | | |
| 6 | 1.73 | 2.45 | 3.01 | 3.48 | 4.27 | 4.93 | 6.06 | 7.03 | 8.67 | | | | | | | |
| 8 | 2.00 | 2.83 | 3.47 | 4.01 | 4.92 | 5.69 | 6.98 | 8.09 | 9.96 | 11.56 | | | | | | |
| 10 | 2.24 | 3.17 | 3.88 | 4.48 | 5.49 | 6.35 | 7.80 | 9.02 | 11.10 | 12.87 | 14.45 | | | | | |
| 12 | 2.45 | 3.47 | 4.25 | 4.91 | 6.02 | 6.95 | 8.53 | 9.87 | 12.13 | 14.06 | 15.77 | 17.35 | | | | |
| 14 | 2.65 | 3.74 | 4.59 | 5.30 | 6.50 | 7.51 | 9.21 | 10.65 | 13.08 | 15.15 | 16.99 | 18.67 | | | | |
| 16 | 2.83 | 4.00 | 4.90 | 5.66 | 6.94 | 8.02 | 9.84 | 11.37 | 13.97 | 16.17 | 18.13 | 19.92 | 23.13 | | | |
| 18 | 3.00 | 4.25 | 5.20 | 6.01 | 7.36 | 8.51 | 10.43 | 12.06 | 14.80 | 17.13 | 19.20 | 21.08 | 24.47 | | | |
| 20 | 3.16 | 4.47 | 5.48 | 6.33 | 7.76 | 8.96 | 10.99 | 12.70 | 15.59 | 18.04 | 20.21 | 22.19 | 25.74 | 28.91 | | |
| 25 | 3.54 | 5.00 | 6.13 | 7.08 | 8.07 | 10.02 | 12.28 | 14.19 | 17.41 | 21.14 | 22.55 | 24.75 | 28.68 | 32.18 | | |
| 30 | 3.87 | 5.48 | 6.71 | 7.75 | 9.50 | 10.97 | 13.44 | 15.54 | 19.05 | 22.03 | 24.67 | 27.06 | 31.34 | 35.14 | | |
| 35 | 4.18 | 5.92 | 7.25 | 8.37 | 10.26 | 11.85 | 14.52 | 16.77 | 20.57 | 23.78 | 26.62 | 29.19 | 33.79 | 37.88 | 54.26 | |
| 40 | 4.47 | 6.33 | 7.75 | 8.95 | 10.96 | 12.66 | 15.52 | 17.93 | 21.98 | 25.40 | 28.43 | 31.18 | 36.08 | 40.43 | 57.82 | |
| 45 | 4.74 | 6.71 | 8.22 | 9.49 | 11.63 | 13.43 | 16.45 | 19.01 | 23.30 | 26.93 | 30.14 | 33.05 | 38.23 | 42.83 | 61.17 | |
| 50 | 5.00 | 7.07 | 8.66 | 10.00 | 12.26 | 14.15 | 17.34 | 20.03 | 24.56 | 28.38 | 31.76 | 34.82 | 40.27 | 45.10 | 64.35 | 79.54 |
| 60 | 5.48 | 7.75 | 9.49 | 10.96 | 13.42 | 15.50 | 18.99 | 21.94 | 26.89 | 31.07 | 34.76 | 38.11 | 44.06 | 49.34 | 70.28 | 86.73 |
| 70 | 5.92 | 8.37 | 10.25 | 11.84 | 14.50 | 16.74 | 20.51 | 23.69 | 29.03 | 33.55 | 37.53 | 41.14 | 47.56 | 53.24 | 75.75 | 93.37 |
| 80 | 6.32 | 8.95 | 10.96 | 12.65 | 15.50 | 17.90 | 21.93 | 25.32 | 31.03 | 35.85 | 40.10 | 43.96 | 50.81 | 56.87 | 80.86 | 99.58 |
| 90 | 6.71 | 9.49 | 11.62 | 13.42 | 16.44 | 18.98 | 23.25 | 26.86 | 32.91 | 38.02 | 42.53 | 46.61 | 53.87 | 60.28 | 85.66 | 105.42 |
| 100 | 7.07 | 10.00 | 12.25 | 14.15 | 17.33 | 20.01 | 24.51 | 28.31 | 34.68 | 40.07 | 44.82 | 49.11 | 56.76 | 63.51 | 90.21 | 110.96 |
| 110 | 7.42 | 10.49 | 12.85 | 14.84 | 18.17 | 20.98 | 25.71 | 29.69 | 36.37 | 42.02 | 46.99 | 51.50 | 59.51 | 66.59 | 94.53 | 115.24 |
| 120 | 7.75 | 10.96 | 13.42 | 15.49 | 18.98 | 21.92 | 26.85 | 31.01 | 37.99 | 43.88 | 49.08 | 53.78 | 62.14 | 69.52 | 98.67 | 121.29 |

Note: Applicable for static bend only

Calculating Minimum Lengths for 45°, 90°, and 180° Bends of Thorburn Hose Assemblies

Determine the centerline bend radius required for your application. Under the column headed "Centerline bend radius in inches", find your radius and read horizontally to the desired degree of bend (45°, 90° or 180°).

The number in that column will be the minimum live length required to make that degree of bend, along the desired centerline radius.

Note: Add fitting length dimension "A", plus the minimum live length to calculate OAL.

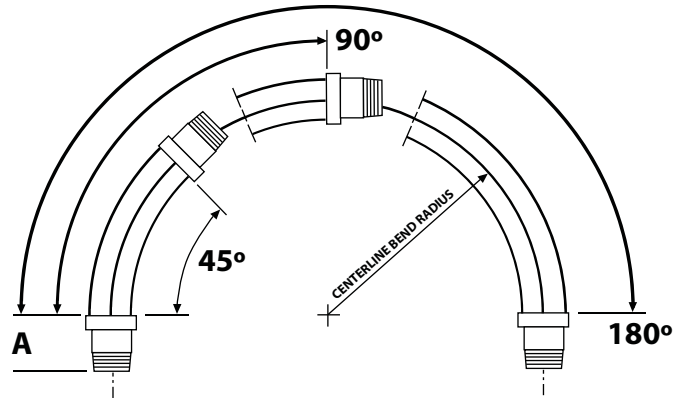

| Centerline Bend Radius (in) | Minimum Live Length (in) | | |
|-----------------------------|--------------------------|--------|------|
| | 45° | 90° | 180° |
| 1 | 1 | 2 | 4 |
| 2 | 2 | 3 1/2 | 7 |
| 3 | 2 1/2 | 5 | 10 |
| 4 | 3 1/2 | 6 1/2 | 13 |
| 5 | 4 | 8 | 16 |
| 6 | 5 | 10 | 20 |
| 7 | 5 1/2 | 11 | 22 |
| 8 | 6 1/2 | 13 | 26 |
| 9 | 7 1/2 | 14 1/2 | 29 |
| 10 | 8 | 16 | 32 |
| 11 | 9 | 18 | 36 |
| 12 | 10 | 19 1/2 | 39 |
| 13 | 10 1/2 | 21 | 42 |
| 14 | 11 1/2 | 22 1/2 | 45 |
| 15 | 12 | 24 | 48 |
| 16 | 13 | 26 | 52 |
| 17 | 13 1/2 | 27 | 54 |
| 18 | 14 1/2 | 29 | 58 |
| 19 | 15 1/2 | 30 1/2 | 61 |
| 20 | 16 | 32 | 64 |
| 21 | 17 | 33 1/2 | 67 |
| 22 | 17 1/2 | 35 | 70 |
| 23 | 18 1/2 | 36 1/2 | 73 |
| 24 | 19 | 38 | 76 |
| 25 | 20 | 40 | 80 |

| Centerline Bend Radius (in) | Minimum Live Length (in) | | |
|-----------------------------|--------------------------|--------|------|
| | 45° | 90° | 180° |
| 26 | 21 | 42 | 83 |
| 27 | 21 1/2 | 43 | 86 |
| 28 | 22 1/2 | 44 1/2 | 89 |
| 29 | 23 | 46 | 92 |
| 30 | 24 | 48 | 95 |
| 31 | 24 1/2 | 49 | 98 |
| 32 | 25 1/2 | 51 | 101 |
| 34 | 27 | 54 | 108 |
| 36 | 28 1/2 | 57 | 114 |
| 38 | 30 | 60 | 120 |
| 40 | 32 | 63 | 126 |
| 45 | 36 | 72 | 144 |
| 50 | 40 | 80 | 160 |
| 55 | 45 | 90 | 180 |
| 60 | 49 | 97 | 194 |
| 65 | 53 | 105 | 210 |
| 70 | 56 | 112 | 224 |
| 80 | 65 | 130 | 260 |
| 90 | 73 | 145 | 290 |
| 100 | 80 | 160 | 320 |
| 120 | 95 | 190 | 380 |
| 140 | 112 | 225 | 450 |
| 160 | 128 | 255 | 510 |
| 180 | 148 | 285 | 570 |
| 200 | 160 | 320 | 640 |

Installing Thorburn Hose Assemblies

Thorburn flexible hose assemblies are manufactured to the highest quality levels to assure maximum service life. The following precautions should be adhered to when installing a flexible hose assembly.

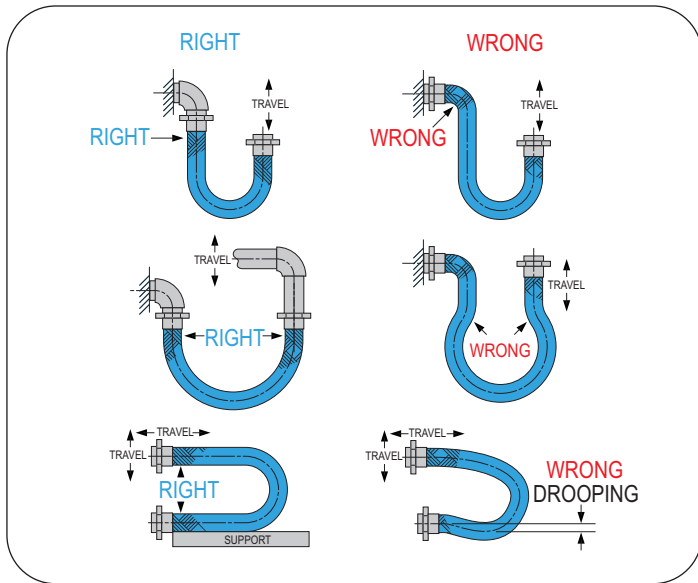

Avoid Overbending

Overbending a Thorburn hose can result in premature failure. This often occurs at the end connections and may be avoided by installing an elbow or interlock guard.

Avoid Improper Handling

Thorburn hoses can be damaged by dragging or when subjected to external abrasive or corrosive conditions. Avoid installing hose in areas where they may be subjected to corrosive sprays, spills, etc.

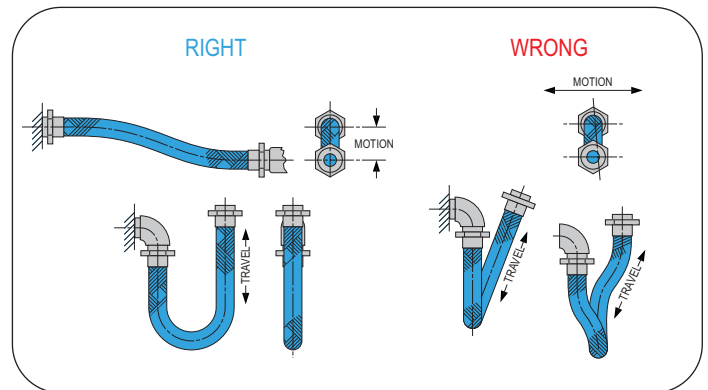

Avoid Torque

Torquing or twisting a Thorburn hose reduces service life substantially. When installing a hose, it is important that all movement originates in the same plane as the center line. Another precaution against torque is the use of a floating flange or union on one end of the assembly.

Calculations for minimum live length excluding end fittings

Thorburn flexible hose assemblies are usually flexed in accordance with one or a combination of the modes of motion shown below. To obtain maximum reliability it is essential to calculate the length of an assembly that will not be flexed beyond the minimum bend radius. The following formulas give a guide in determining the length of tube required. They are based on standard applications using our current product range. Variations should be discussed with Thorburn's technical department.

- L** = Minimum Live Length excluding end fitting
- R** = Minimum Bend Radius
- T** = Total Travel
- K** = Loop Length
- π = 3.142

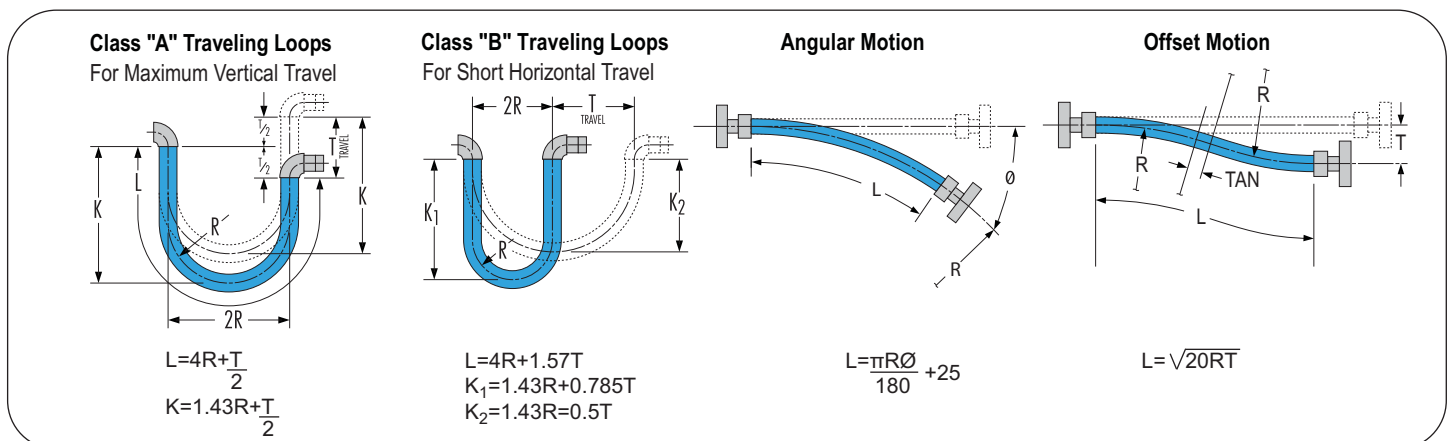

Pipe Anchoring Guide

A piping system which utilizes Thorburn flexible hose assemblies to absorb pipe movement must be properly anchored and guided to assure correct functioning and maximum service life of the hose. The basic principles to be observed are:

- 1) The direction of pipe motion must be perpendicular to the center line (axis) of the hose.
- 2) The pipe must be anchored at each change of direction where a flexible hose is employed to prevent torsional stress.

Typical examples of **RIGHT** and **WRONG** guiding are shown below.

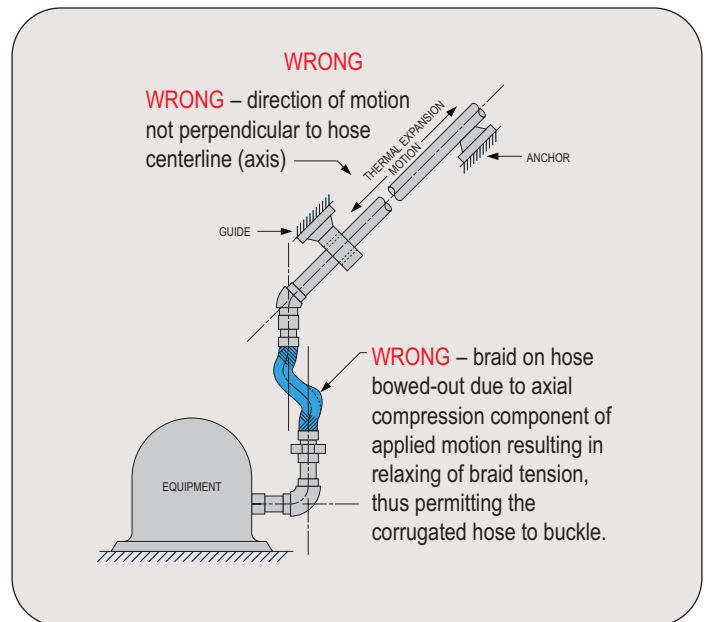
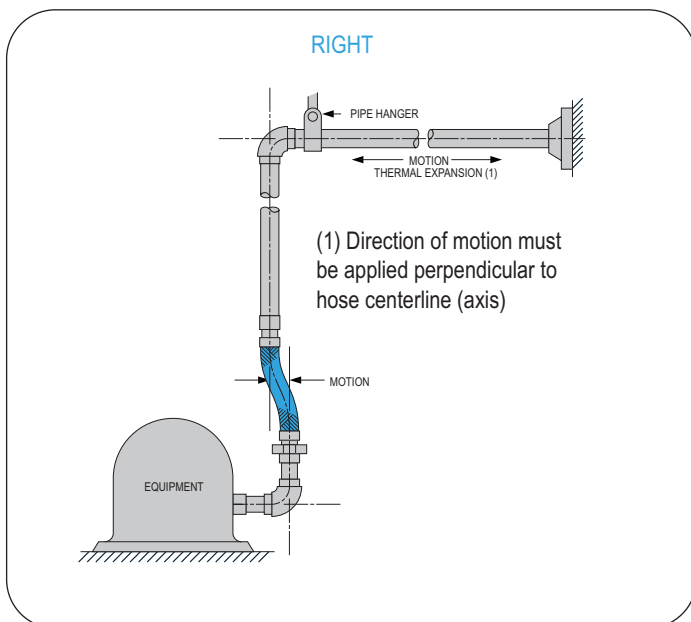
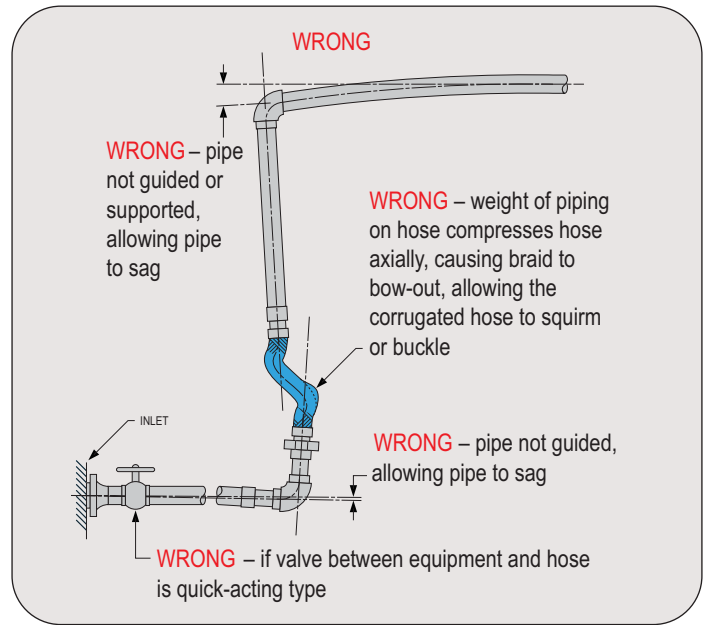
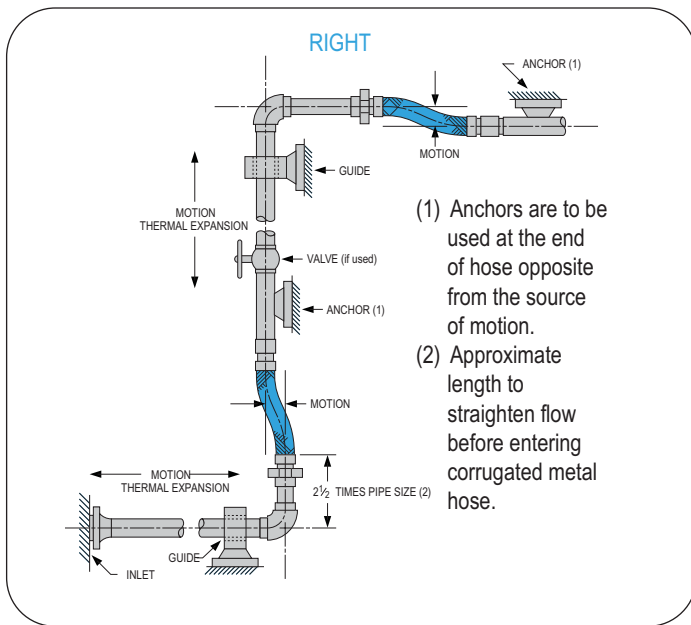

Chemical Resistance and Effusion



Material Compatibility Key:

- A** Excellent Resistance
- B** Fair Resistance
- C** Depends on Conditions
- D** Not Recommended
- No Information

Effusion Compatibility Key:

1. Effusion will occur with potential to displace breathable air in an enclosed environment.
2. Potential to effuse and, with atmosphere, form chemicals that can corrode braid and fitting material. Especially significant when “vapor phase” exists, i.e., when they reach their boiling point of approximately 125°F at atmospheric pressure. Hose assemblies should be used in well-vented areas only.
3. Potential for effusion can cause corrosion of the hose braid reinforcement and fitting material. These chemicals are all gases at atmospheric pressure and at temperatures of 56°F (12°C) or lower. Consult factory for applications other than room temperature.

Electrostatic Discharge:

In many industrial plants, there is an awareness that electrostatic discharge can be a hazard. This discharge is the result of two unlike materials coming into contact. This contact allows electrons from one material to move across its boundary and associate with the other. For example, electrons from steam can align with the wall of a PTFE hose. If both materials are good conductors of electricity, the positive and negative electrons flow back and forth between the chemical and hose wall, keeping them in balance. However, if one or both of them are insulators, the balance will be disrupted. As a result, chemicals such as gasoline or steam, flowing through a white PTFE hose will deposit electrons on the wall of the innercore, building up static charge. When the charge exceeds the dielectric strength of the hose wall, dielectric breakdown occurs.

Chemical Resistance & Effusion Data

| Chemical | PTFE | Effusion | ETFE | PVDF |
|---------------------------------|------|----------|------|------|
| Acetal | A | | - | - |
| Acetaldehyde | A | 2 | A | D |
| Acetamide | A | | A | C |
| Acetate Solvents | A | | - | A |
| Acetic Acid, 10% | A | | - | A |
| Acetic Acid, 30% | A | | - | B |
| Acetic Acid, 50% | A | | A | B |
| Acetic Acid, Glacial | A | | A | A |
| Acetic Anhydride | A | | A | D |
| Acetic Ester (Ethyl Acetate) | A | | - | - |
| Acetic Ether (Ethyl Acetate) | A | | - | - |
| Acetic Oxide (Acetic Anhydride) | A | | - | B |
| Acetone | A | | A | A |
| Acetophenone | A | | A | - |
| Acetyl Acetone | A | | - | - |
| Acetyl Chloride | A | | A | A |
| Acetylene | A | 3 | A | A |
| Acrylonitrile | A | | A | A |
| Air | A | | A | - |
| Alcohol Aliphatic | B | | - | - |
| Alcohol, Aromatic | A | | - | - |
| Alk-Tri (Trichloroethylene) | A | | - | - |
| Allyl Alcohol | A | | A | - |
| Allyl Bromide | A | | - | - |
| Allyl Chloride | A | | A | - |
| Alum (Alum Potassium Sulfate) | A | | - | A |
| Aluminum Acetate | A | | - | - |
| Aluminum Chloride | A | | A | A |
| Aluminum Fluoride | A | | A | A |
| Aluminum Hydroxide | A | | A | A |
| Aluminum Phosphate | A | | - | - |
| Aluminum Nitrate | A | | - | A |
| Aluminum Sulfate | A | | - | A |
| Ammonia, Liquid | A | | - | A |
| Ammonia in Water | A | | - | A |
| Ammonium Carbonate | A | | A | A |
| Ammonium Chloride | A | | A | A |
| Ammonium Hydroxide | A | | A | A |
| Ammonium Metaphosphate | A | | - | A |
| Ammonium Nitrate | A | | A | A |
| Ammonium Persulfate | A | | A | A |
| Ammonium Phosphate | A | | A | - |
| Ammonium Sulfate | A | | A | A |
| Ammonium Sulfide | A | | A | - |
| Ammonium Sulfite | A | | - | - |
| Ammonium Thiocyanate | A | | A | A |
| Ammonium Thiosulfate | A | | - | - |
| Amyl Acetate | A | | A | A |

| Chemical | PTFE | Effusion | ETFE | PVDF |
|---------------------------|------|----------|------|------|
| Amyl Acetone | A | | - | - |
| Amyl Alcohol | A | - | A | A |
| Amyl Borate | A | | - | - |
| Amyl Chloride | A | | A | A |
| Amyl Chloronapthalene | A | | - | - |
| Amyl Napthalene | A | | - | - |
| Amyl Oleate | A | | - | - |
| Amyl Phenol | A | | - | - |
| Anethole | A | | - | - |
| Aniline | B | | A | A |
| Aniline Dyes | A | | - | - |
| Aniline Hydrochloride | A | | A | B |
| Animal Fats | A | | - | A |
| Animal Grease | A | | - | A |
| Animal Oils | A | | - | A |
| Ansul Ether | A | | - | - |
| Antifreeze | A | | - | - |
| Antimony Chloride | A | | - | - |
| Antimony Pentachloride | A | | - | - |
| Aqua Regia | B | | A | A |
| Aromatic Hydrocarbons | A | | - | A |
| Arquad | A | | - | - |
| Arsenic Acid | A | | A | A |
| Arsenic Chloride | A | | A | - |
| Arsenic Trichloride | A | | - | - |
| Asphalt | A | | - | A |
| ASTM #1 Oil | A | | - | - |
| ASTM #2 Oil | A | | - | - |
| ASTM #3 Oil | A | | - | - |
| Aviation Gasoline | A | | - | - |
| Barium Carbonate | A | | A | A |
| Barium Chloride | A | | A | A |
| Barium Hydroxide | A | | A | A |
| Barium Sulfate | A | | A | A |
| Barium Sulfide | A | 2 | A | A |
| Beer | A | | - | A |
| Beet Sugar Liquor | A | | - | A |
| Benzaldehyde | A | | A | A |
| Benzene (Benzol) | A | 2 | A | A |
| Benzene Sulphonic Acid | A | | A | B |
| Benzene Solvent (Ligroin) | A | | - | - |
| Benzoic Acid | A | | A | A |
| Benzoic Aldehyde | A | | - | - |
| Benzotrichloride | A | | - | - |
| Benzoyl Chloride | A | | A | A |
| Benzyl Acetate | A | | - | - |
| Benzyl Alcohol | A | | A | A |
| Benzyl Chloride | A | | A | C |

Chemical Resistance & Effusion Data

| Chemical | PTFE | Effusion | ETFE | PVDF |
|--|-------------------|----------|------|------|
| Bichromate of Soda (Sodium Dichromate) | A | | - | - |
| Black Sulfate Liquor | A | | - | A |
| Blast Furnace Gas | A | 3 | - | - |
| Bleach Solutions | A | | A | - |
| Borax | A | | A | A |
| Bordeaux Mixture | A | | - | - |
| Brandy | FDA Tube Required | | | |
| Brine | A | | - | A |
| Bromine | A | | A | A |
| Bromine Water | A | | A | A |
| Bromobenzene | A | | A | A |
| Bunker Oil | A | | - | - |
| Butanol | A | | - | A |
| Butane | A | 3 | A | A |
| Butter | A | | - | A |
| Butyl Acetate | A | | A | A |
| Butyl Acrylate | A | | A | C |
| Butylamine | A | | A | A |
| Butyl Benzene | - | | - | - |
| Butyl Bromide | A | | A | A |
| Butyl Butyrate | A | | - | - |
| Butyl Carbitol | A | | - | - |
| Butyl Cellosolve | A | | - | B |
| Butyl Chloride | A | | A | A |
| Butyl Ether | A | | - | A |
| Butyl Ethyl Acetaldehyde | - | | - | - |
| Butyl Ethyl Ether | A | | - | - |
| Butyl Oleate | A | | - | - |
| Butyl Phthalate | A | | A | D |
| Butyl Stearate | A | | - | A |
| Butyraldehyde | A | | A | B |
| Butyric Acid | A | | - | A |
| Butyric Anhydride | A | | A | - |
| Calcium Acetate | A | | - | - |
| Calcium Bisulfate | A | | A | - |
| Calcium Bisulfite | A | | - | D |
| Calcium Carbonate | A | | A | A |
| Calcium Chloride | A | | A | A |
| Calcium Hydroxide | A | | A | A |
| Calcium Hypochlorite | A | | A | A |
| Calcium Nitrate | A | | A | A |
| Calcium Oxide | A | | A | A |
| Calcium Salts | - | | - | - |
| Calcium Sulfate | A | | A | D |
| Calcium Sulfide | A | | A | A |
| Calcium Sulfite | A | | - | - |
| Caliche Liquor | A | | - | - |
| Cane Sugar Liquors | A | | - | A |

| Chemical | PTFE | Effusion | ETFE | PVDF |
|-------------------------|------|----------|------|------|
| Carbitol | A | | - | A |
| Carbitol Acetate | - | | - | - |
| Carbolic Acid | A | | - | B |
| Carbon Bisulfide | A | | - | A |
| Carbon Dioxide | A | 1 | A | A |
| Carbon Disulfide | A | | A | A |
| Carbonic Acid | A | | A | A |
| Carbon Monoxide | A | 3 | A | B |
| Carbon Tetrachloride | A | | B | A |
| Carbon Tetrafluoride | A | | - | - |
| Castor Oil | A | | A | - |
| Caustic Potash | A | | A | A |
| Caustic Soda | - | | A | A |
| Cellosolve | A | | A | A |
| Cellulose Acetate | A | | - | - |
| Cellulube | A | | - | - |
| China Wood Oil | A | | - | - |
| Chlorine Dioxide | A | | - | A |
| Chlorine Gas | A | | - | - |
| Chlorine Water Solns | A | | - | B |
| Chloroacetic Acid | A | | A | A |
| Chloroacetone | A | | - | - |
| Chlorobenzene | A | | A | A |
| Chlorobutane | - | | - | - |
| Chlorobutadiene | A | | - | - |
| Chloroform | A | | B | A |
| Chlorinated Hydrocarbon | A | | - | - |
| Chloropentane | - | | - | - |
| Chlorophenol | A | | - | - |
| Chloropropanone | A | | - | - |
| Chlorosulfonic Acid | A | | A | D |
| Chlorothene | A | | - | - |
| Chlorotoluene | A | | - | - |
| Chromic Acid | A | | - | A |
| Citric Acid | A | | - | A |
| Coal Oil | - | | - | - |
| Coal Tar | A | | - | - |
| Coal Tar Naptha | A | | - | - |
| Cobalt Chloride | A | | - | - |
| Coconut Oil | A | | - | A |
| Cod Liver Oil | A | | - | A |
| Coke Oven Gas | A | | - | A |
| Copper Arsenate | A | | - | - |
| Copper Chloride | A | | A | A |
| Copper Cyanide | A | | A | A |
| Copper Nitrate | A | | A | A |
| Copper Nitrite | A | | - | A |
| Copper Sulfate | A | | A | A |

Chemical Resistance & Effusion Data

| Chemical | PTFE | Effusion | ETFE | PVDF |
|------------------------------------|------|----------|------|------|
| Copper Sulfide | A | | - | - |
| Corn Oil | A | | - | A |
| Cottonseed Oil | A | | - | - |
| Creosote (Coal Tar) | A | | - | - |
| Creosote (Wood) | A | | - | - |
| Creosols | A | | A | A |
| Cresylic Acid | A | | A | B |
| Crude Oil | A | | A | A |
| Cumeme | A | | - | - |
| Cupric Carbonate | A | | - | - |
| Cupric Chloride | A | | - | B |
| Cupric Nitrate | A | | - | - |
| Cupric Nitrite | A | | - | - |
| Cupric Sulfate | A | | - | - |
| Cyclohexane | A | | A | A |
| Cyclohexanone | A | | A | D |
| Cyclohexanol | A | | A | A |
| Cyclopentane | A | | - | - |
| P-Cymene | A | | - | - |
| DDT in Kerosene | A | | A | - |
| Decaline | A | | A | A |
| Decane | A | | A | A |
| Detergent Solutions | A | | - | A |
| Diacetone Alcohol | A | | A | D |
| Dibenzyl Ether | A | | - | C |
| Dibenzylsebacate | A | | - | - |
| Dibromobenzene | A | | - | - |
| Dibutyl Amine | A | | - | B |
| Dibutyl Ether | A | | - | C |
| Dibutyl Phthalate | A | | A | D |
| Dibutyl Sebacate | A | | - | D |
| Dicalcium Phosphate | A | | - | - |
| Dichloroacetic Acid | A | | A | - |
| P-Dichlorobenzene | A | | A | A |
| Dichlorobutane | A | | - | - |
| Dichloroisopropyl Ether | A | | - | - |
| Dichlorodifluoromethane (Freon 12) | A | | - | - |
| Dichloroethane | A | | - | A |
| Dichloroethylene | A | | A | A |
| Dichloroethyl Ether | A | | - | - |
| Dichlorohexane | A | | - | - |
| Dichloromethane | A | | - | - |
| Dichloropentane | A | | - | - |
| Dieldrin in Xylene | - | | - | - |
| Dieldrin in Xylene & Water Spray | - | | - | - |
| Diesel Oil | A | | - | A |
| Diethanolamine | A | | - | - |
| Diethylamine | A | | A | D |

| Chemical | PTFE | Effusion | ETFE | PVDF |
|------------------------------|------|----------|------|------|
| Diethyl Benzene | A | | A | - |
| Diethyl Ether | A | 2 | - | B |
| Diethylene Dioxide | A | | - | - |
| Diethyl Oxalate | A | | - | - |
| Diethyl Phthalate | A | | - | - |
| Diethyl Sebacate | A | | - | - |
| Diethyl Sulfate | A | | - | - |
| Diethyl Triamine | A | | - | - |
| Dihydroxyethyl Ether | A | | - | - |
| Diisobutylene | A | | - | A |
| Diisobutyl Ketone | A | | A | - |
| Diiaodecyl Adipate | A | | - | - |
| Diisodecyl Phthalate | A | | - | - |
| Diisooctyl Adipate | A | | - | - |
| Diisooctyl Phthalate | A | | - | - |
| Diisopropanol Amine | A | | - | - |
| Diisopropyl Benzene | A | | - | - |
| Diisopropyl Ether | A | | - | - |
| Diisopropyl Ketone | A | | - | A |
| Dilauryl Ether | A | | - | - |
| Dimethyl Benzene | A | | - | - |
| Dimethylaniline | A | | A | B |
| Dimethylformamide (DMF) | A | | A | D |
| Dimethyl Ketone (Acetone) | A | | - | - |
| Dimethyl Phthalate | A | | A | B |
| Dimethyl Sulfate | A | | A | - |
| Dimethyl Sulfide | A | | - | - |
| Dinitrobenzene | A | | - | - |
| Dinitrotoluene | A | | - | - |
| Diocetyl Adipate (DOA) | A | | - | - |
| Diocetyl Phthalate (DOP) | A | | - | B |
| Diocetyl Sebacate (DOS) | A | | - | - |
| Dioxane | A | | - | C |
| Dioxolane | A | | A | - |
| Dipentene (Limonene) | A | | - | - |
| Diphenyl (Biphenyl) | A | | - | A |
| Dipropyl Ketone | A | | - | - |
| Disodium Phosphate | A | | - | - |
| Divinyl Benzene | A | | - | - |
| D.M.P. (Dimethyl Phenols) | A | | - | - |
| Dodecyl Benzene | A | | A | - |
| Diphenyl Oxide (Phenylether) | - | | - | - |
| Dipropylene Glycol | A | | - | - |
| Dodecyl Toluene | A | | - | - |
| Dowdume W 40, 100% | - | | - | - |
| Dow-Per (Perchloroethylene) | A | | - | - |
| Dowtherm Oil, A & E | A | | - | - |
| Dowtherm S.R.I. | A | | - | - |

Chemical Resistance & Effusion Data

| Chemical | PTFE | Effusion | ETFE | PVDF |
|--|------|----------|------|------|
| Dry Cleaning Fluids | A | | - | A |
| Epichlorohydrin | A | | A | D |
| Ethanol (Ethyl Alcohol) | A | | - | A |
| Ethers | A | | A | D |
| Ethyl Acetate | A | | A | D |
| Ethyl Acetaoacetate | A | | - | A |
| Ethyl Acrylate | A | | A | C |
| Ethyl Benzene | A | | - | C |
| Ethyl Benzoate | - | | - | D |
| Ethyl Butyl Alcohol | A | | - | - |
| Athyl Butyl Ketone | A | | - | - |
| Ethyl Cellulose | A | | - | - |
| Ethyl Chloride | A | 3 | - | A |
| Ethyl Dichloride | A | | - | - |
| Ethylene | - | | - | - |
| Ethylene Bromide | A | | A | A |
| Ethylene Chloride | A | | A | A |
| Ethylene Dibromide | A | | - | A |
| Ethylene Dichloride | A | | - | A |
| Ethylene Glycol | A | | A | A |
| Ethylene Oxide | A | | A | A |
| Ethylene Trichloride (Trichloroethylene) | A | | - | A |
| Ethyl Ether | A | | - | B |
| Ethyl Formate | A | | - | - |
| Ethyl Hexanol | A | | - | - |
| Ethyl Methyl Ketone | A | | - | - |
| Ethyl Oxalate | A | | - | - |
| Ethyl Phthalate | A | | - | - |
| Ethyl Propyl Ether | - | | - | - |
| Ethyl Propyl Ketone | A | | - | - |
| Ethyl Silicate | A | | - | - |
| Ethyl Sulfate | A | | - | - |
| EX TRI (Trichlorethylene) | A | | - | - |
| Fatty Acids | A | | A | A |
| Ferric Bromide | A | | - | - |
| Ferric Chloride | A | | A | A |
| Ferric Nitrate | A | | A | A |
| Ferric Sulfate | A | | A | A |
| Ferrous Acetate | A | | - | - |
| Ferrous Ammonium Sulfate | - | | - | - |
| Ferrous Chloride | A | | - | - |
| Ferrous Hydroxide | A | | - | - |
| Ferrous Sulphate | A | | - | A |
| Fish Oil | A | | - | - |
| Fluoroboric Acid | A | | A | A |
| Fluorine | D | | - | A |
| Fluorosilic Acid | A | | A | B |
| Formaldehyde (Formalin) | B | | A | A |

| Chemical | PTFE | Effusion | ETFE | PVDF |
|----------------------|------|----------|------|------|
| Formamide | A | | | - |
| Formic Acid | A | | A | A |
| Freon 11 | A | | A | B |
| Freon 12 | A | 1 | A | B |
| Freon 13 | A | | - | A |
| Freon 21 | A | 1 | - | A |
| Freon 22 | A | 1 | A | B |
| Freon 31 | A | | - | - |
| Freon 32 | A | | - | - |
| Freon 112 | A | | - | - |
| Freon 113 | A | 1 | A | B |
| Freon 114 | A | 1 | - | A |
| Freon 115 | A | | - | - |
| Freon 142b | A | | - | - |
| Freon 152a | A | | - | - |
| Freon 218 | A | | - | - |
| Freon C316 | A | | - | - |
| Freon C318 | A | | - | - |
| Freon 13B1 | A | | - | - |
| Freon 114B2 | A | | - | - |
| Freon 502 | A | | - | - |
| Freon TF | A | | - | B |
| Freon T-WD 602 | A | | - | - |
| Freon TMC | A | | - | - |
| Freon T-P35 | A | | - | - |
| Freon TA | A | | - | - |
| Freon TC | A | | - | - |
| Freon MF | A | | - | - |
| Freon BF | A | | - | - |
| Fuel Oil | A | | A | - |
| Fuel, ASTM A | A | | - | - |
| Fuel, ASTM B | A | | - | - |
| Fuel, ASTM C | A | | - | - |
| Fumaric Acid | A | | A | - |
| Furane | A | | A | D |
| Furfural | A | | A | B |
| Furfuryl Alcohol | A | | - | B |
| Gallic Acid | B | | A | B |
| Gasoline, Reg | A | | A | C |
| Gasoline, Hi-Test | A | | - | - |
| Gasoline, Lead Free | A | | A | C |
| Gelatin | A | | - | A |
| Gluconic Acid | A | | - | - |
| Glucose | A | | - | A |
| Glue | A | | - | A |
| Glycerine (Glycerol) | A | | - | A |
| Glycois | A | | - | A |
| Grease | A | | - | A |

Chemical Resistance & Effusion Data

| Chemical | PTFE | Effusion | ETFE | PVDF |
|---|------|----------|------|------|
| Green Sulfate Liquor | A | | | - |
| Halowax Oil | A | | | - |
| Heptachlor in (Petroleum Solvents) | A | | | - |
| Heptachlor in (Petro-Solvents, Water Spray) | - | | | - |
| Heptanal (Heptaldehyde) | A | | | - |
| Heptane | A | | A | A |
| Heptane Carboxylic Acid | A | | | - |
| Hexaldehyde | A | | | - |
| Hexane | A | | A | A |
| Hexene | A | | | - |
| Hexanol (Hexyl Alcohol) | A | | | - |
| Hexylene | A | | | - |
| Hexylene Glycol | A | | | - |
| Hexyl Methyl Ketone | A | | | - |
| Hi-Tri (Trichloroethylene) | A | | | - |
| Hydraulic Fluid (Petroleum) | A | | | - |
| Hydraulic Fluid (Phosphate Ester Base) | A | | - | - |
| Hydraulic Fluid (Poly Alkylene Glycol Base) | - | | - | - |
| Hydrobromic Acid | A | | - | A |
| Hydrobromic Acid, 5% | A | | - | - |
| Hydrobromic Acid, 15% | A | | - | - |
| Hydrobromic Acid, 37% | A | | - | - |
| Hydrocyanic Acid | A | | A | A |
| Hydrofluoric Acid | A | | A | A |
| Hydrofluosilic Acid | A | | A | A |
| Hydrogen Gas | A | 3 | A | A |
| Hydrogen Peroxide, 3% | A | | A | A |
| Hydrogen Peroxide, 10% | A | | A | A |
| Hydrogen Peroxide, 30% | A | | A | A |
| Hydrogen Peroxide, 90% | A | | A | A |
| Hydrogen Sulfide | - | 3 | A | A |
| Hydroquinone | A | | A | A |
| Hypochlorous Acid | A | | A | A |
| Ink Oil (Linseed Oil Base) | A | | - | A |
| Insulating Oil | A | | - | - |
| Iodine | A | | A | A |
| Iron Acetate | A | | - | - |
| Iron Hydroxide | A | | - | - |
| Iron Salts | A | | - | - |
| Iron Sulfate | A | | - | - |
| Iron Sulfide | A | | - | - |
| Isomyl Acetate | A | | - | - |
| Isomyl Alcohol | A | | - | - |
| Isoamyl Bromide | A | | - | - |
| Isoamyl Butyrate | A | | - | - |
| Isoamyl Chloride | A | | - | - |
| Isomyl Ether | A | | - | - |
| Isoamyl Phthalate | A | | - | - |

| Chemical | PTFE | Effusion | ETFE | PVDF |
|--|------|----------|------|------|
| Isobutanol (Isobutyl Alcohol) | A | | A | - |
| Isobutyl Acetate | A | | - | - |
| Isobutyl Aldehyde | A | | - | - |
| Isobutyl Amine | A | | - | - |
| Isobutyl Bromide | A | | - | - |
| Isobutyl Carbinol | A | | - | - |
| Isobutyl Chloride | A | | - | - |
| Isobutylene | A | | - | - |
| Isobutyl Ether | A | | - | - |
| Isocyanates | A | | - | - |
| Isoctane | A | | - | A |
| Isopentane | A | | - | - |
| Isopropyl Acetate | A | | - | D |
| Isopropyl Alcohol (iso-propanol) | A | | - | A |
| Isopropyl Amine | A | | A | - |
| Isopropyl Benzene | A | | - | - |
| Isopropyl Chloride | A | | - | - |
| Isopropyl Ether | A | | - | D |
| Isopropyl Toluene | A | | - | - |
| Jet Fuels (JP1-JP6) | A | | A | B |
| Kerosene | A | | - | A |
| Ketones | A | | - | D |
| Lactic Acid | A | | A | C |
| Lacquers | A | | - | D |
| Lacquer Solvents | A | 2 | - | D |
| Lard | A | | A | A |
| Lauryl Alcohol | A | | - | - |
| Lead Acetate | A | | - | A |
| Lead Nitrate | A | | - | A |
| Lead Sulfamate | B | | - | A |
| Lead Sulfate | A | | - | - |
| Ligroin | A | | - | A |
| Lime Water | A | | - | A |
| Linseed Oil | A | | A | - |
| Lindol (Tricresyl Phosphate) | A | | - | - |
| Liquid Soap | A | | - | - |
| Liquid Petroleum Gas | A | | - | A |
| Lubricating Oils | A | | A | A |
| Lye (Sodium Hydroxide) | A | | - | D |
| Magnesium Acetate | A | | - | - |
| Magnesium Carbonate | A | | A | A |
| Magnesium Chloride | A | | A | A |
| Magnesium Hydrate | A | | - | A |
| Magnesium Hydroxide | A | | A | A |
| Magnesium Nitrate | A | | A | A |
| Magnesium Sulfate | A | | A | A |
| Malathion 50 in (Aromatic Solvents) | A | | - | - |
| Malathion 50 in (Arom. Solv., Water Spray) | A | | - | - |

Chemical Resistance & Effusion Data

| Chemical | PTFE | Effusion | ETFE | PVDF |
|--------------------------------------|------|----------|------|------|
| Maleic Acid | A | | A | A |
| Maleic Anhydride | A | | A | A |
| Malic Acid | A | | - | A |
| Manganese Sulfate | A | | - | A |
| Manganese Sulfide | A | | - | - |
| Manganese Sulfite | A | | - | - |
| Mercuric Chloride | A | | A | - |
| Mercury | A | | A | A |
| Methane | A | | A | A |
| Methyl Acetate | A | | - | B |
| Methyl Acrylate | A | | - | B |
| Methacrylic Acid | - | | - | - |
| Methyl Alcohol (Methanol) | A | | A | A |
| Methyl Benzene (Toluene) | A | | - | - |
| Methyl Bromide | A | 2 | A | A |
| Methyl Butyl Ketone | A | | - | D |
| Methyl Cellosolve | A | | A | A |
| Methyl Chloride | A | 2 | A | A |
| Methyl Cyclohexane | A | | - | - |
| Methylene Bromide | A | | A | A |
| Methylene Chloride | A | | A | D |
| Methyl Ethyl Ketone (MEK) | A | | - | D |
| Methyl Formate | A | 2 | - | - |
| Methyl Hexanol | A | | - | - |
| Methyl Hexyl Ketone | A | | - | - |
| Methyl Isobutyl Carbinol | A | | - | - |
| Methyl Isobutyl Ketone (MIBK) | A | | A | D |
| Methyl Isopropyl Ketone | A | | - | A |
| Methyl Propyl Ether | A | | - | - |
| Methyl Propyl Ketone | A | | - | - |
| Methyl Methacrylate | A | | - | - |
| Methyl Salicylate | A | | - | B |
| Methyl tert-Butyl Ether (MTBE) | D | | - | - |
| Mineral Oil | A | | - | A |
| Mineral Spirits | A | | - | - |
| Monochlorobenzene | A | | A | B |
| Monochlorodifluoromethane (Freon 22) | A | | - | B |
| Monomethylether | A | | A | - |
| Monovinyl Acetylene | A | | - | - |
| Motor Oil | A | | A | B |
| Muriatic Acid | A | | - | A |
| Naphtha | B | | A | A |
| Napthalene | A | | A | A |
| Napthenic Acid | A | | - | - |
| Neatsfoot Oil | A | | - | - |
| Neu-Tri (Trichloroethylene) | A | | - | - |
| Nickel Acetate | A | | - | A |
| Nickel Chloride | A | | A | A |

| Chemical | PTFE | Effusion | ETFE | PVDF |
|-----------------------------------|------|----------|------|------|
| Nickel Nitrate | A | | A | A |
| Nickel Plating Solution | A | | - | - |
| Nickel Sulfate | A | | A | A |
| Niter Cake | A | | - | - |
| Nitric Acid, 10% | A | | A | A |
| Nitric Acid, 20% | A | | A | A |
| Nitric Acid, 30% | A | | A | A |
| Nitric Acid, 30-70% | A | | A | A |
| Nitric Acid, Red Fuming | A | | - | D |
| Nitrobenzene | A | | - | B |
| Nitrogen Gas | A | 1 | A | A |
| Nitrogen Tetraoxide | A | | - | C |
| Nitromethane | A | | A | B |
| Nitropropane | A | | - | - |
| Nitrous Oxide | A | | - | D |
| Octadecanoic Acid | A | | - | - |
| Octane | A | | A | - |
| Octanol (Octyl Alcohol) | A | | - | - |
| Octyl Acetate | A | | - | - |
| Octyl Carbinol | A | | - | - |
| Octylene Glycol | A | | - | - |
| Oil, Petroleum | A | | A | - |
| Oil, ASTM #1 | A | | A | - |
| Oil, ASTM #2 | A | | A | - |
| Oil, ASTM #3 | A | | A | - |
| Oleic Acid | A | | - | A |
| Oleum (Fuming Sulfuric Acid) | A | | A | D |
| Olive Oil (Non FDA) | A | | - | B |
| Orthodichlorobenzene | A | | - | - |
| Oxalic Acid (Cold) | A | | - | B |
| Oxygen, Cold | A | 1 | A | A |
| Oxygen, HotB | A | 1 | A | A |
| Ozone | A | | A | A |
| Paint Thinner (Duco) | A | | - | - |
| Palmitic Acid (Hexadecanoic Acid) | A | | A | A |
| Palm Oil | A | | - | A |
| Papermaker's Alum | A | | - | - |
| Paradichlorobenzene | - | | - | - |
| Paraffin | A | | - | A |
| Paraformaldehyde | A | | - | - |
| Peanut Oil | A | | - | A |
| Pentane | A | | - | A |
| Perchloroethylene | A | | A | A |
| Perchloric Acid | D | | A | A |
| Petrolatum | C | | A | A |
| Petroleum, Crude | A | | A | A |
| Petroleum Ether (Naphtha) | A | | A | B |
| Petroleum Oils | A | | - | A |

Chemical Resistance & Effusion Data

| Chemical | PTFE | Effusion | ETFE | PVDF |
|----------------------------------|------|----------|------|------|
| Phenol 10% | A | | A | A |
| Phenol Sulfonic Acid | A | | A | B |
| Phenyl Chloride | A | | - | - |
| Phenyldiazine | A | | A | D |
| Phorone | A | | - | - |
| Phosphate Esters | A | | - | - |
| Phosphoric Acid, 10% | A | | A | A |
| Phosphoric Acid, 10-85% | A | | A | A |
| Phosphorous Trichloride | A | | A | A |
| Pickling Solution | A | | - | - |
| Picric Acid, Molten | A | | A | A |
| Picric Acid, Water Soln. | A | | A | - |
| Pinene | A | | - | - |
| Pine Oil | A | | - | B |
| Piperidine | A | | - | - |
| Pitch | A | | | - |
| Plating Solution, Chrome | A | | A | B |
| Plating Solution, Others | A | | A | - |
| Polyvinyl Acetate Emulsion (PVA) | A | | A | A |
| Polyethylene Glycol | A | | - | - |
| Polypropylene Glycol | A | | - | - |
| Potassium Bicarbonate | A | | A | B |
| Potassium Bisulfate | A | | - | A |
| Potassium Bisulfite | A | | - | - |
| Potassium Carbonate | A | | A | A |
| Potassium Chloride | A | | A | A |
| Potassium Chromate | A | | A | B |
| Potassium Cyanide | A | | A | A |
| Potassium Dichromate | A | | A | A |
| Potassium Hydrate | A | | - | - |
| Potassium Hydroxide | A | | A | A |
| Potassium Nitrate | A | | A | A |
| Potassium Permanganate | A | | A | A |
| Potassium Silicate | A | | - | - |
| Potassium Sulfate | A | | A | A |
| Potassium Sulfide | A | | A | A |
| Potassium Sulfite | A | | - | A |
| Producer Gas | A | | - | - |
| Propanediol | A | | - | - |
| Propyl Acetate | A | | - | A |
| Propyl Alcohol (Propanol) | A | | A | A |
| Propyl Aldehyde | A | | - | - |
| Propyl Chloride | A | | - | - |
| Propylene Dichloride | A | | A | - |
| Propylene Glycol | A | | - | A |
| Pydraul Hydraulic Fluids | A | | - | - |
| Pyranol | A | | - | - |
| Pyridine | A | | A | D |

| Chemical | PTFE | Effusion | ETFE | PVDF |
|------------------------------------|------|----------|------|-------------------|
| Pyroligneous Acid | A | | - | B |
| Pyrrrole | A | | - | - |
| Rape Seed Oil | A | | - | A |
| Red Oil (Crude Oleic Acid) | A | | - | - |
| Richfield A Weed Killer, 100% | A | | - | - |
| Richfield B Wedd Killer, 33% | A | | - | - |
| Rosin Oil | - | | - | A |
| Rotenone and Water | A | | - | - |
| Rum | | | | FDA Tube Required |
| Sal Ammoniac (Ammonium Chloride) | A | | - | A |
| Salicylic Acid | A | | A | A |
| Salt Water (Sea Water) | A | | A | A |
| Sewage | A | | - | A |
| Silicate of Soda (Sodium Silicate) | A | | - | - |
| Silicate Esters | A | | - | - |
| Silicone Greases | A | | - | - |
| Silicone Oils | A | | - | A |
| Silver Nitrate | A | | A | A |
| Skelly Solvent | - | | - | - |
| Skydrol Hydraulic Fluids | A | | A | - |
| Soap Solutions | A | | - | A |
| Soda Ash (Sodium Carbonate) | A | | - | A |
| Soda, Caustic (Sodium Hydroxide) | A | | - | A |
| Soda, Lime | A | | - | - |
| Soda Niter (Sodium Nitrate) | A | | - | A |
| Sodium Acetate | A | | A | A |
| Sodium Aluminate | A | | - | A |
| Sodium Bicarbonate | A | | A | A |
| Sodium Bisulfate | A | | A | A |
| Sodium Bisulfite | A | | A | A |
| Sodium Borate | A | | A | A |
| Sodium Carbonate | A | | A | A |
| Sodium Chloride | A | | A | A |
| Sodium Chromate | A | | A | A |
| Sodium Cyanide | A | | A | A |
| Sodium Dichromate | A | | A | A |
| Sodium Fluoride | A | | A | A |
| Sodium Hydroxide | A | | A | A |
| Sodium Hypochlorite | A | | - | B |
| Sodium Metaphosphate | A | | - | A |
| Sodium Nitrate | A | | A | A |
| Sodium Nitrite | A | | A | A |
| Sodium Perborate | A | | A | A |
| Sodium Peroxide | A | | A | A |
| Sodium Phosphate | A | | A | A |
| Sodium Silicate | A | | A | A |
| Sodium Sulfate | A | | A | A |
| Sodium Sulfide | A | | A | A |

Chemical Resistance & Effusion Data

| Chemical | PTFE | Effusion | ETFE | PVDF |
|-----------------------------------|------|----------|------|------|
| Sodium Sulfite | A | | A | A |
| Sodium Thiosulfate | A | | A | A |
| Soybean Oil | A | | - | B |
| Stannic Chloride | A | | - | A |
| Stannic Sulfide | A | | - | - |
| Stannous Chloride | A | | A | A |
| Stannous Sulfide | A | | - | - |
| Stearic Acid | A | | A | A |
| Stoddards Solvent | A | | A | - |
| Styrene | A | | A | B |
| Sugar Sols. (Sucrose) Non FDA | A | | - | A |
| Sulfamic Acid | A | | A | - |
| Sulfite Liquors | A | | - | - |
| Sulfonic Acid | A | | - | - |
| Sulfur (Molten) | A | | A | A |
| Sulfur Chloride | A | | - | A |
| Sulfur Dioxide | A | 3 | A | A |
| Sulfur Hexafluoride | A | | - | - |
| Sulfur Trioxide | A | 2 | A | D |
| Sulfuric Acid, 25% | A | | A | A |
| Sulfuric Acid, 25-50% | A | | A | A |
| Sulfuric Acid, Fuming | A | | A | D |
| Sulfurous Acid | A | | A | A |
| Tall Oil | A | | A | A |
| Tallow | A | | - | - |
| Tannic Acid | A | | A | B |
| Tar | A | | - | A |
| Tartaric Acid | A | | A | B |
| Terpineol | A | | - | - |
| Tertiary Butyl Alcohol | A | | - | - |
| Tetrachlorobenzene | A | | - | - |
| Tetrachloroethane | A | | - | - |
| Tetrachloroethylene | A | | - | - |
| Tetraethylene Glycol | A | | - | - |
| Tetrachloromethane | A | | - | - |
| Tetrachloronaphthalene | A | | - | - |
| Tetraethyl Lead | A | | A | - |
| Tetrahydrofuran (THF) | A | | A | - |
| Thionyl Chloride | A | | A | - |
| Tin Chloride | A | | - | - |
| Tin Tetrachloride | A | | A | - |
| Titanium Tetrachloride | A | | A | - |
| Toluene (Toluol) | A | | A | - |
| Toluene Diisocyanate (TDI) | A | | - | - |
| Toxaphene | - | | - | - |
| Transformer Oils (Petroleum Base) | A | | - | - |
| Transformer Oils | A | | - | - |

| Chemical | PTFE | Effusion | ETFE | PVDF |
|------------------------------------|------|----------|------|-------------------|
| (Chlorinated Phenyl Base Askerels) | | | | |
| Transmission Fluids - A | A | | A | - |
| Transmission Fluids - B | - | | - | - |
| Triacetin | A | | - | - |
| Tributyl Phosphate | A | | A | A |
| Trichlorobenzene | A | | - | - |
| Trichloroethane | A | | - | B |
| Trichloroethylene | A | | A | D |
| Trichloropropane | A | | - | - |
| Tricresyl Phosphate (TCP) | A | | - | D |
| Triethylene Glycol | A | | - | - |
| Trinitrotoluene (TNT) | A | | - | - |
| Triphenyl Phosphate | A | | - | - |
| Trisodium Phosphate | A | | A | - |
| Tung Oil | A | | - | A |
| Turbine Oil | A | | - | A |
| Turpentine | A | | A | A |
| 2, 4D with 10% Fuel Oil | - | | - | - |
| Ucon Hydrolube Oils | A | | - | - |
| Undecanol | A | | - | - |
| Unsymmetrical Dimethyl-Hydrazine | A | | - | A |
| Uran | - | | - | - |
| Varnish | A | | - | A |
| Vegetable Oils | A | | - | A |
| Versilube | A | | - | - |
| Vinegar | A | | - | B |
| Vinyl Acetate | A | | A | A |
| Vinyl Benzene | A | | - | - |
| Vinyl Chloride (Monomer) | A | 3 | A | B |
| Vinyl Ether | - | | - | - |
| Vinyl Toluene | A | | - | - |
| Vinyl Trichloride | A | | - | - |
| V.M. & P. Naptha | A | | - | - |
| Water, Fresh (Non FDA) | A | | A | A |
| Water, Salt | A | | A | A |
| Whiskey, Wines | | | | FDA Tube Required |
| White Liquor | A | | - | A |
| White Oil | A | | - | - |
| Wood Alcohol (Methanol) | A | | - | - |
| Xylene (Xy101) | A | | A | A |
| Xylidine | A | | - | - |
| Zeolites | A | | - | - |
| Zinc Acetate | A | | A | A |
| Zinc Carbonate | A | | - | - |
| Zinc Chloride | A | | A | A |
| Zinc Chromate | A | | - | - |
| Zinc Sulfate | A | | A | A |



ThorburnFlex

ThorburnFlex

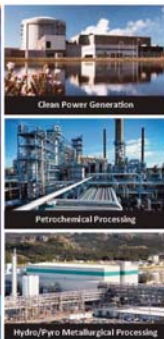

METALLIC HOSE ASSEMBLIES
Engineered Solutions For Pipe Motion

www.thorburnflex.com

Metallic Hose Assemblies Catalog

Thorburn Flex provides end-user engineered solutions for pipe motion. You specify the operating conditions and we will produce a custom metal hose assembly that will satisfy the operating conditions. Thorburn's metal hose assemblies may be exceptionally flexible, or you may need several hoses encapsulated in outer hose: a jacketed hose for heat exchange; an armoured hose; a hose to carry sensitive cables; an articulated robotic cover; an insulated hose; a colour coded hose. Our "Can-Do" design specialists are only a phone call away.

Applications



Clean Power Generation



LNG Transfer



Petro-Chemical Processing



Pulp & Paper Processing

THORBURN FLEX - Canada
 165 Oneida, Pointe-Claire, Quebec
 Canada, H9R 1A9
 Tel: +1-514-695-8710
 Fax: +1-514-695-1321
 sales@thorburnflex.com



ISCIR Romania | CNCAN Romania | EN 13480-2002 | HAF 604 China | TSG China
 (CRN for all Canadian Provinces)

Thorburn's Global Presence

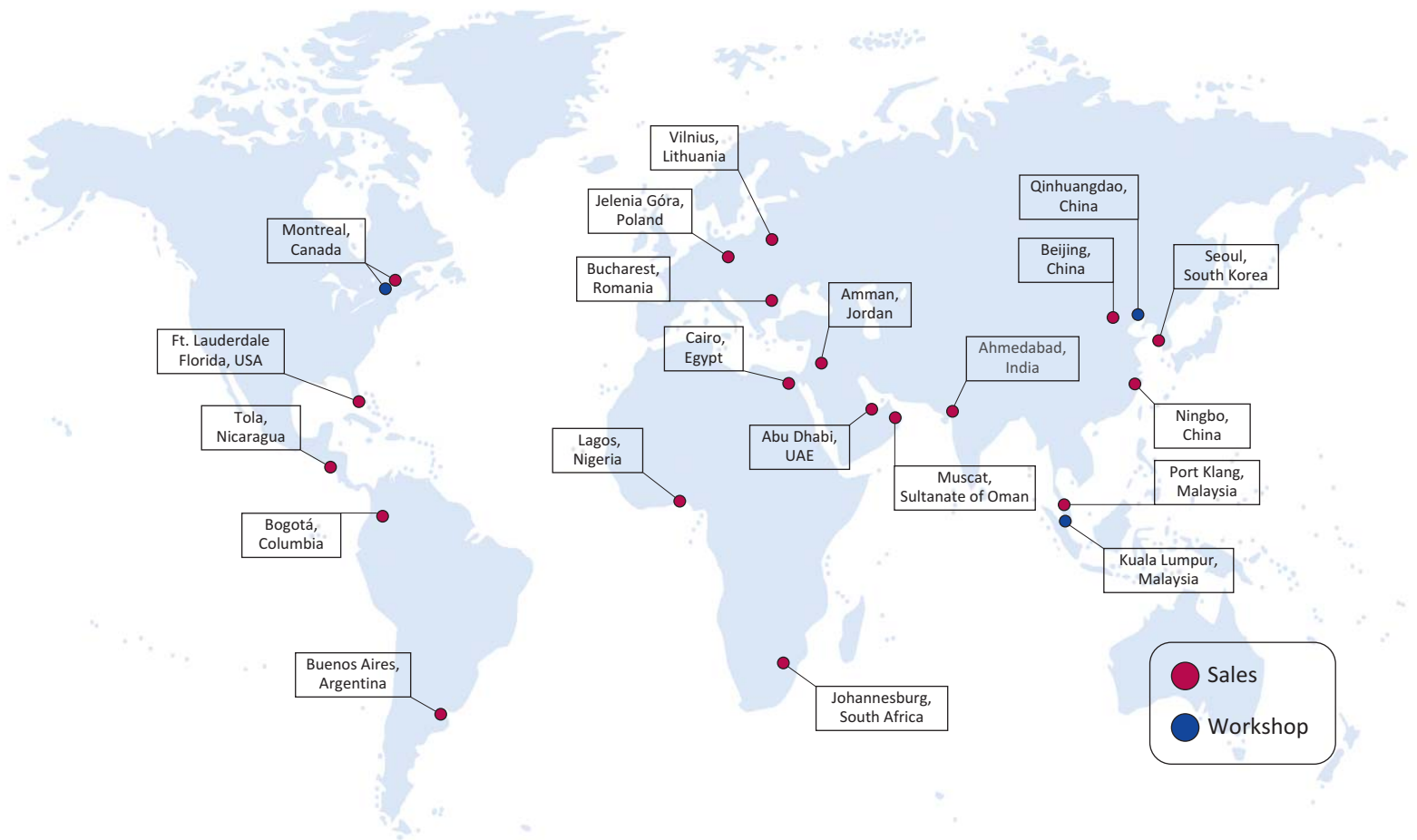

www.thorburnflex.com