

ThorburnFlex



Metallic Expansion Joints



Fabric Expansion Joints



Rubber Expansion Joints

POWER GENERATION

Engineered Solutions For Pipe Motion



www.thorburnflex.com

High Quality Custom Flexible Piping & Ducting Systems

Thorburn Flex Inc is a proven industry leader in the cost effective design, development, manufacturing and supply of ultra-high quality custom flexible piping and ducting systems. Thorburn Flex Inc is committed to a policy of continuous development and research to provide flexible piping products that set the industry standard for quality, safety, durability and ease of handling.



METALLIC EXPANSION JOINT APPLICATIONS

- Steam Turbine Crossover
- Coal Pulverizer
- HRSG Piping System
- Extraction Steam Piping
- Boiler Feedpump
- Boiler Penetration Seals

FABRIC EXPANSION JOINT APPLICATIONS

- Turbine Rotor Air Cooling
- Turbine Exhaust to Diverter Inlet
- Turbine Outlet Stack
- Diverter Bypass to Stack
- Steam Generator to Stack
- Primary Air to Recovery Boiler
- Precipitator to Chimney
- Scrubber to Re-Heater



RUBBER EXPANSION JOINT APPLICATIONS

- HVAC
- Turbine to Condensor
- Compressors
- Dust Recovery Systems
- Pumps
- Circulating Water Lines
- Process Piping
- Ventilating Systems

Operating under a strategy of global presence in niche markets, Thorburn is structured to consistently meet and exceed customer expectations of quality and value. Thorburn is also chosen by clients who understand successful project execution is based on selecting vendors who consistently provide on-time deliveries.

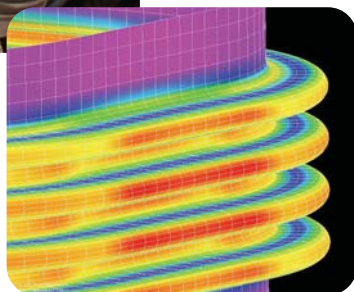

SITE SERVICES

Thorburn Flex Inc provides our clients with specialized site services such as installation supervision, quality control inspection, training, outage planning, expansion joint counter measure repair and installation.

Our staff can provide answers to piping and ducting problems by performing on-site piping stress and finite element analysis, measuring the results against the actual failure mode. Our services Include...

- Stress analyses to verify design.
- Assistance in drawing regeneration or updates.
- Guidance in the installation & maintenance.
- On-site consultation, engineering & training sessions.
- Maintenance service during shutdowns & turnarounds
- Refurbishing, retrofitting, repairing & replacements

Inline Dual Purpose Pressure Balanced Expansion Joints

The Inline Dual Purpose Pressure Balanced Expansion Joint's unique design addresses the deficiencies in standard inline pressure balanced expansion joints in that it balances the pressure thrust while concurrently allowing for axial and lateral movement. It is fully capable of handling both axial and lateral movement through the use of universal line bellows and spherical washers while maintaining constant pipeline volume by absorbing axial thermal growth.

- Absorbs axial deflection
- Absorbs lateral deflection independently from the balancing and line bellows
- Neutralizes pressure thrust forces
- Eliminates the requirement for main anchors
- Protects sensitive equipment against detrimental pressure thrust forces

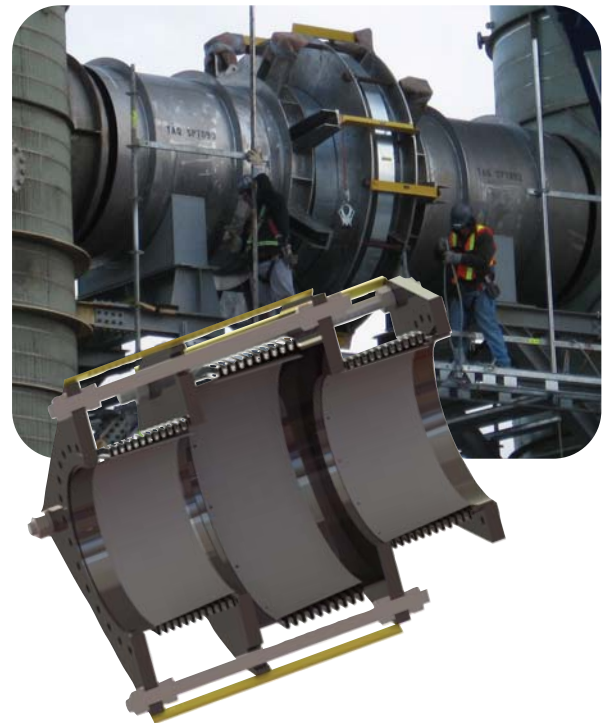

Inlet HRSG Gas Turbine Expansion Joints

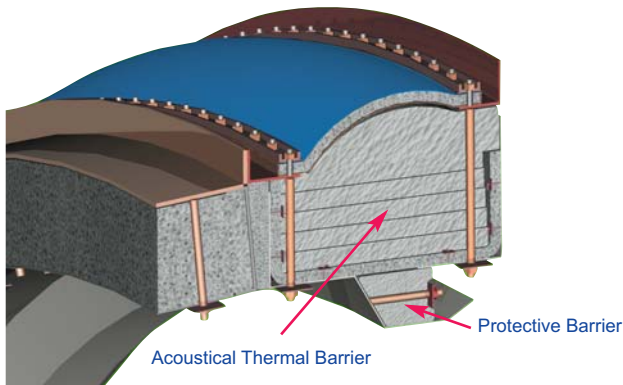
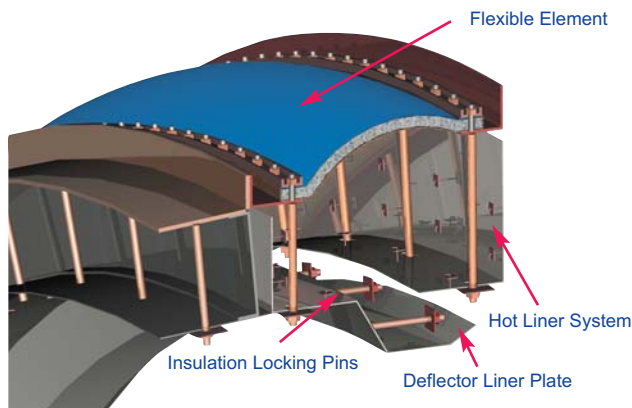

Cold to Cold Frame Design

- Free floating hot liner system allows positive independent thermal expansion.
- Inlet deflector liner plate prevents vortex effect & protects the cavity during turbine washing.
- Internal pins lock & secure insulation during operation.
- Liner material is made from SA240 type 409/410SS.

Thermal & Acoustical Barriers

- Thermal insulation barrier reduces the 625 °C inner hot face temperature to 60°C on the flexible element's outer coils face.
- Flexible element temperature without added insulation up to 1100°C
- The acoustical barrier reduces noise level from 134 dBA @ 800Hz to 66.7 dBA at 1m distance.
- Flexible element design is impervious to internal & external corrosion.

THORBURN FLEX - Canada
 165 Oneida, Pointe-Claire, Quebec
 Canada, H9R 1A9
 Tel: +1-514-695-8710
 Fax: +1-514-695-1321
 sales@thorburnflex.com
 1-800-363-6613
 (Toll Free North America)



ISCIR Romania | CNCAN Romania | EN 13480-2002 | HAF 604 China | TSG China

42HP-PB In-line Rubber Pressure Balanced Expansion Joints

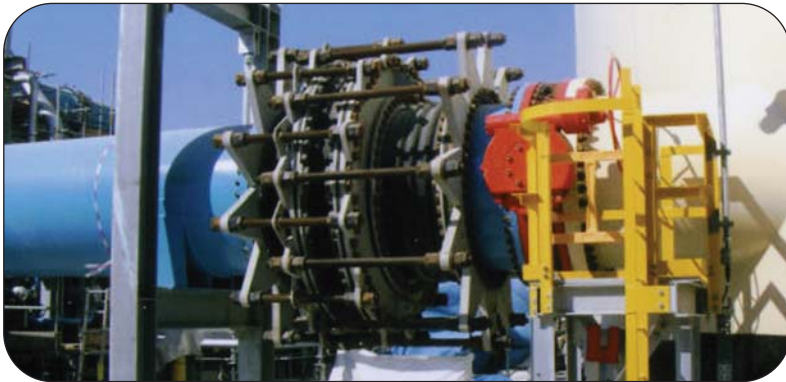

Eliminates pressure thrust loads on your piping system while absorbing axial & lateral movement. An alternative to metallic in-line pressure balanced bellows expansion joints, which are susceptible to failures from corrosive media, cyclic loading conditions and solids from settling into the thin walled metallic convolutions.

Design

- ASME B31.1, B31.3 Pressure Piping Certification
- FSA Technical Handbook 8th Edition
- Sizes 12.7mm (1/2") to 4000mm (276") ID
- Pressures full vacuum to 20 bar
- Available with CRN

Thorburn's 42HP-PB Advantages

Neutralizes Pressure Thrust:

Pressure balanced control rod system is custom designed to absorb the full pressure thrust forces, dead weight loads and eliminates the requirement for main anchors

Replaces Pipe Loops:

Reduces piping energy by eliminating pressure losses generated by the loop elbow

Extremely Compact:

Greater flexibility in piping layout

Filled arches:

Smooth unrestricted flow prevents media sediment buildup.

Freedom from Corrosion and Embrittlement:

Impervious to corrosive media degradation, flex fatigue and shock

Super Abrasive and Erosion Resistance:

Available with smooth filled arches, abrasive resistant lining protects against sea water salt, slurry and other abrasive media

Wetted Metal Components Can Be Cladded or Rubber Lined:

Enhances corrosion & abrasive resistance at a fraction of the cost.

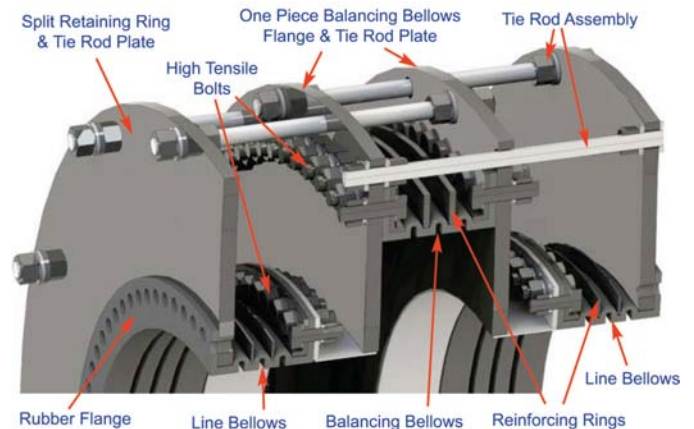

*Over 50 years of flexible piping experience
 waiting to serve you...*