

ThorburnFlex



Clean Power Generation



Petrochemical Processing



Hydro/Pyro Metallurgical Processing

RUBBER EXPANSION JOINTS Engineered Solutions For Pipe Motion



www.thorburnflex.com



ThorburnFlex

Thorburn Flex is an innovative manufacturer of specialized engineered flexible piping systems (i.e. custom hose assemblies and expansion joints). Since 1954, Thorburn’s corporate mission evolution and business philosophy has been customer driven and targeted to select niche applications where Thorburn can achieve clear positions of sustainable technological and market share leadership. Thorburn Flex is committed to a policy of continuous development and research to provide engineered solutions for pipe motion that set the industry standards for quality, safety, environmental protection, durability and value.



European
Conformity



ISO
9001



B31.1,
B31.3



ASME “NPT”
Sec. III Class 1



ASME “U”
Sec. VIII Div. 1



N285.0, B51
CGA CR96-001



97/23/EC
Module H



UL
536

ISCIR Romania | CNCAN Romania | EN 13480-2002 | HAF 604 China | TSG China

www.thorburnflex.com

Table Of Contents

Introduction	4 to 11
Spool Type Expansion Joints	12 to 15
Wide Arch Expansion Joints	16 to 23
Rectangular Arch Type Expansion Joints	24
Dog Bone Expansion Joints	25
Control Rod Assemblies	26 to 28
Retaining Rings & Mating Flange Thicknesses	29
Special Purpose (Hinge, Gimbal & Pressure Balanced) Expansion Joints	30 to 31
Common Flange Dimensions & Drilling Chart	32
Optional Flange Drilling	33
Easy-Flex Spherical Type Expansion Joints	34 to 41
Style TM21 Molded Full Face Rubber Flange Expansion Joints	42
Series 301EF Ultra High Pressure Rubber Expansion Joints	43 to 44
Tef-Flex PTFE Expansion Joints	45 to 46
Hot-Flex PTFE lined Metallic Expansion Joints	47
Rubber Lined Metallic Expansion Joints	48
Deep Sea & Underground Rubber Expansion Joints	49
Metallic Protective Covers for Rubber Expansion Joints	49
Thorshield Spray Shields	50
Rubber Expansion Joint Installation Tips & Suggestions	51 to 53
Pump Connectors	54 to 55
Rubber Connector Hose Assemblies	56 to 57
Flexi-Pipe Hose Assemblies	58
Field Attachable Fitting to End Joints For Flexi-Pipe Hose Assemblies	59
Flexi-Pipe Ordering Codes	60
Flexi-Pipe Fittings	61 to 63
Dismantling Joints	64 to 67
Definitions	68 to 73
Chemical Resistance Charts	74 to 81
How To Order Thorburn's Pressure Piping Rubber Expansion Joints	82
Ceramic Lined Flexi-Pipe	83



A Proven Leader in Rubber Pressure Piping Expansion Joints

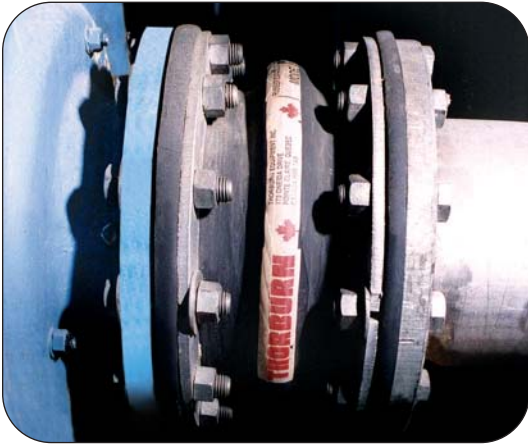

Thorburn's 42HPW 200mm (8") Single Arch Rubber Expansion Joint

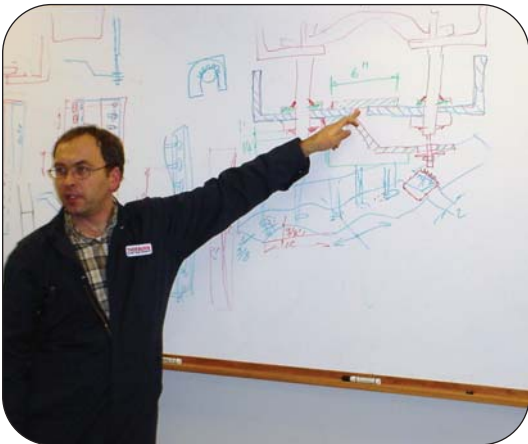

Thorburn engineers provide on-site installation, maintenance and handling training



Thorburn's site team instructing a technician on how to properly install Thorburn's Mighty Spool pressure piping expansion joints

Thorburn has been solving the most challenging pipe motion problems for over 50 years

Operating under a global presence and employing the most talented and dedicated specialists in the world, Thorburn provides our clients with the latest technologies and solutions in rubber piping expansion joints. Thorburn has gained international acclaim as the world's most innovative, solutions driven, rubber expansion joint manufacturer with manufacturing and support capabilities in Canada, Mexico, South Africa, Nigeria, Egypt, Poland, Australia, Malaysia, Indonesia and China, and has representation and engineering presence in USA, Argentina, Chile, Jordan, Saudi Arabia, Iran, Romania, Lithuania, Belarus, Russia, Japan and South Korea.

Thorburn's Major Strengths in Rubber Expansion Joints

- Customer driven, single point contact for ease of communication
- Global manufacturing capabilities close to job sites to decrease costs and increase support
- Experienced engineers providing reliability through best industry practices and standards
- Advanced design software such as FEA to address the challenges of thermal, vibration and mechanical stress

Thorburn's Pressure Piping Expansion Joint Services

- Failure mode investigation, analysis, recommendations & countermeasures
- Expansion joint installation training
- Expansion joint installation verification and inspection
- Expansion joint optimal design selection assistance
- Expansion joint storage, maintenance and handling training
- Section by section survey evaluating the condition of all expansion joints
- Establish maintenance priority list and change-out schedule
- Emergency installation & repairs
- Final site inspection before and after commissioning

Quality Standards & Compliances

- ASME B31.1 and B31.3 pressure piping registration
- Rubber Manufacturers Association RMA-IP-2
- Fluid Sealing Association (FSA), Rubber Expansion Joint Division, Technical Handbook 8.0 Ed.
- CSA CAN3 Z299.1 QMI certified / N285.0
- ISO 9001-2015 Edition
- ASME Section III NCA-4000 Subsection NQA-1
- Welders and Welding Procedures, ASME section IX, VIII B31.1 and B31.3
- CRN for all Canadian Provinces

Thorburn's Rubber Pressure Piping Expansion Joints



Advantages

- Compact to simplify installation
- Absorbs movement in all directions
- Reduces mechanical noises
- Compensates for misalignment
- Eliminates electrolysis between dissimilar metals
- Relieves strain in the piping system

Thorburn rubber expansion joints are custom designed by engineers and fabricated by skilled craftsmen following rigid step-by-step quality control standards. Thorburn's rubber expansion joints are used to neutralize stress and solve defined pipe motion problems. The question often facing piping engineers is when to use a rubber expansion joint rather than use a metallic expansion joint.

Why Choose Thorburn's Rubber Expansion Joints Over Metallic

High Resistance to Shock

Unlike a metal joint, Thorburn rubber expansion joints absorb movements in all directions without stress and are capable of preventing unexpected shock induced movements caused by pumps, blowers and other agitating equipment, particularly during plant start-ups or shutdowns.

Vibration and Sound Absorption

Thorburn's elastomeric joints offer significant advantages over a metallic joint by attenuating vibration without the fatigue damage associated with metallic expansion joints.

Freedom From Embrittlement

Failure of a metal expansion joint is due primarily to continuous flexing and built-up stress points resulting in a fracture at the point of embrittlement. Constant/intermittent flexing keeps the rubber "alive" and eliminates flex cracking in Thorburn's rubber expansion joints.

Great Recovery From Movement

When a metal joint is fully compressed, it assumes a permanent set. Thorburn's rubber expansion joint returns to its original position.

Freedom From Corrosion

To achieve comparable corrosion resistance metal bellows would have to employ exotic alloys at a tremendous cost. Thorburn's rubber expansion joints will not corrode in sea water and the continuous flexing prevents scale from forming.

Superior Abrasive and Erosion Resistance

Thin metallic bellows will typically wear out at the root over time with minimum abrasion, whereas a rubber joint can be manufactured with a smooth abrasion resistant lining to protect it from the harmful effects of sea water salt, slurry and other abrasive media.



Thorburn's 42HPW 900mm (36") single arch rubber expansion joint with control rod system

Typical Thorburn Rubber Pressure Piping Expansion Joint Construction

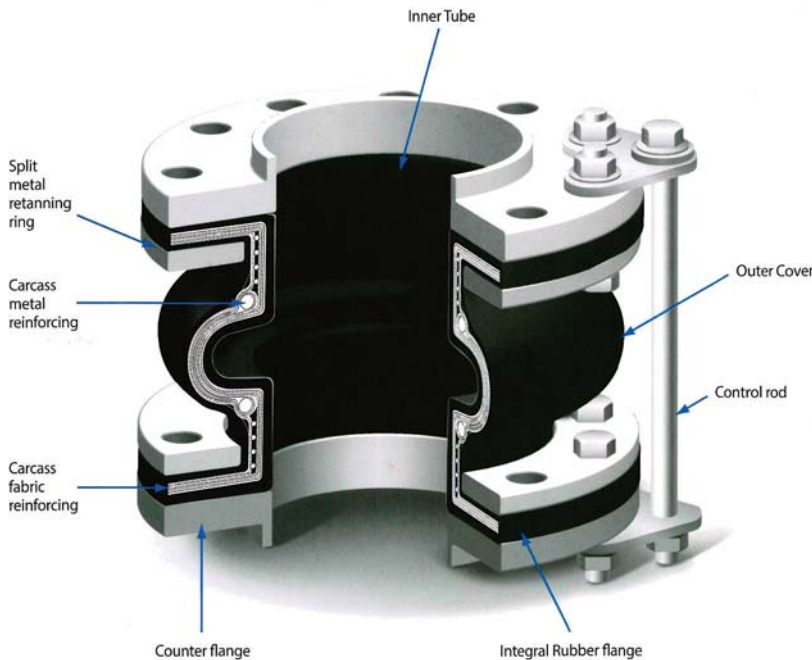

The purpose of Thorburn's rubber piping expansion joints is to relieve strain and stress in a piping system caused by thermal changes, misalignment, seismic activity, equipment vibration, load stresses, pump surges or ground settling

Internal Reinforcement

Fabric: The fabric reinforcement is the flexible and supporting member between the tube and cover. Fabrics of high strength synthetic fibers are used depending on pressure and temperature requirements. All fabric plies are calendered to permit flexibility between the fabric plies and to reduce service strain.

Metallic: The metallic reinforcement consists of coated high tensile spring steel wire and/or solid steel rings embedded in the carcass. The purpose of the metallic reinforcements are to strengthen the joint, permitting the rated working pressures, and to supply the joint with the necessary rigidity for thermal changes and vacuum service. Specially compounded filler rubbers are used between the layers of metallic and textile reinforcement to prevent migration when pressurized. External metallic reinforcement rings are used for high pressure service.

External Reinforcement

Thorburn's Reinforcing Ring Technology is placed within the outside of the arches in high pressure applications. Specifically designed to strengthen the arches themselves, prevent the migration of the reinforcement within the joint and finally to retain the shape of the arches.

Tube

Seamless elastomeric lining that is designed to maintain fluid leak tight integrity of the expansion joint and protect the carcass from penetration or saturation of the media being transferred. Thorburn's expansion joint tubes can be designed to transfer chemical and petroleum products, sewage, gases as well as abrasive media.

Cover

The primary function of the cover is to protect the carcass from outside damage or abuse. Special elastomers can be supplied to resist chemicals, oils, sunlight, acid fumes, ozone, sea water, etc.

End Connections

Integral flanges are constructed of fabric reinforcement, smooth finish, full flat faced flange that form a tight seal against the mating pipe flanges without the need of gaskets (Metal leveling rings or full face rubber gaskets of the same material as the expansion joint tube). Integral flanges are recommended on raised face flanges to flatten the flange surface and prevent cutting of the rubber expansion joint flanges under compression load. Integral rubber flanges can be supplied with standard ANSI, AWWA, DIN, JIS & B.S. & non-standard drilling, offset flanges with different drilling, metallic swivel flanges, different sized inlet/outlet flanges. Soft cuff clamp-on ends designed to fit over a pipe and be clamped on are also available.

Cross Reference Of Common and Standard Chemical names

Common Name	ASTM D1418	Chemical Name
Natural Rubber	NR/IR	Polyisoprene
Urethane3	AU/EU	Polyester/Polyether Urethane
Neoprene	CR	Poly-Chloroprene
Nitrile (BunaN)	NBR	Butadiene Acrylo-Nitrile
Chlorobutyl	CIIR	Chloro-Isobutylene Isoprene
Hypalon	CSM	Chloro-Sulfonated Polyethylene
Bromobutyl	BIIR	Bromo Isobutene Isoprene
EPDM	EPDM	Ethylene Propylene Polymer
Viton	FKM	Fluorinated Hydrocarbon
PTFE	AFMU	Polytetrafluoroethylene
FEP		Fluorinated Ethylene Propylene
Silicone	SI	Poly Siloxane
HNBR		Hydrogenated Nitrile



Thorburn's rubber pressure piping expansion joints are hand crafted by skilled technicians using the most advanced elastomers, calendared fabrics and metallic reinforcements. Sizes from 25mm (1") up to 3600mm (144") with design pressures up to 20 bar with 4 to 1 safety factor

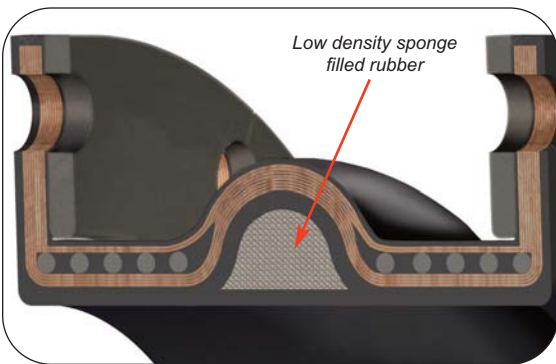

Thorburn's 42HPW high pressure expansion joint with a low density rubber filled arch is designed for smooth unrestricted flow and allows for 50% of open arch movement.

Hand Crafted Quality

Thorburn's Mighty-Spool expansion joints are the work horses of our engineered rubber pressure piping expansion joints. Thorburn does not employ marginal practices or materials, which reduce safety factors. All Thorburn Mighty-Spool joints meet a minimum 4 to 1 safety factor at rated operating temperatures and pressures.

Shape & Size Range

Round DIN 12mm to 3600mm (1/2" to 144") I.D.

Custom Rectangular, concentric, eccentric and transition ends custom built from various elastomers and fabrics. If you have any requirements, call Thorburn for a timely solution.

Arch Types

Thorburn's custom hand-built filled or open arch designs are available in various profiles (spool, double movement extra wide and long flowing spherical) to meet specific application requirements.

Filled Arch System

All Thorburn's Mighty-Spool open arch rubber expansion joint designs may be modified to reduce possible turbulence, prevent the collection of solids in the arch way, which could obstruct the joint movement. To solve such problems, Thorburn's Mighty-Spool joints may be supplied with a bonded-in place soft filler rubber in the arch, providing a smooth interior bore. It should be noted that filled arches reduce movement capability by half (50%) and increase the spring rate by 4 times the normal movements and spring rates of comparable size of Mighty-Spool open arch expansion joints. This general rule is similar for all Thorburn rubber expansion joints with filled arches.

Multiple Arch Designs

Thorburn Mighty-Spool single and multiple arch types are available in different styles, pressures, movement capabilities and spring rates depending upon the application. Mighty-Spool multiple arch expansion joints are composites of the single arch design and are capable of movements of a single arch multiplied by the number of arches. The spring rate for a multi-arch type expansion joint is equal to the spring rate for a single arch design divided by the number of arches. This general rule is similar for all Thorburn rubber expansion joints. In order to maintain lateral stability and prevent sagging when the joint is installed in a horizontal position, a typical maximum number of arches supplied is 4.

Thorburn's 42HPW with 3 low profile wide arches which provides three times the movement of a single arch rubber expansion joint



Mighty Spool Rubber Expansion Joint Technical Data

Flange Bolts: Attach and tighten nuts alternately around the flange until hand tight. torque each bolt to full torque with the cross-bolt pattern until the values given in the table below are reached. A traditional method of tightening full forced flanges until the rubber flange is compressed uniformly to 75% of its original thickness typically results in proper sealing. See Thorburn's IOM for details.

Nominal Bolt Torque Beaded-Ends (Spherical) or PTFE Bellows			
Pipe Size		Torque	
in	mm	ft-lbs	Nm
1-1.25	25-32	30-45	40-60
1.5-2	40-50	30-45	40-60
2.5	65	35-50	47-68
3-5	80-125	45-60	60-80
6-8	150-200	50-65	68-88
10-12	250-300	55-75	75-100
14-16	350-400	60-80	80-110
18	450	70-90	95-120
20	500	75-95	95-120
24	600	80-100	110-135
30	750	95-130	120-175

Nominal Bolt Torque Full Faced Elastomer Flanges			
Pipe Size		Torque	
in	mm	ft-lbs	Nm
1-2	25-50	30-50	40-68
2.5-5	60-125	50-70	68-95
6-8	150-200	90-120	120-160
10-12	250-300	110-140	150-190
14-16	350-400	130-160	175-215
18-24	450-600	150-200	200-270
26-40	650-1000	200-300	270-410
42-54	1050-1400	300-400	410-540
60-72	1500-1800	400-500	540-680

Notes: Recommended torque values are for reference only and may require more or less torque due to flange facing and other variables. **Caution:** Mating flange material or equipment may dictate lower torque values. The flange bolts should be retightened after one week of operation and checked periodically thereafter.

Dimensional Inspection Tolerances

NPS	Thorburn Tolerances for Flexi-Pipe & Expansion Joints							# averaged Measurements
	EJ ID	Flange OD	Bolt Line	Face -To-Face Length (inches)				
				0 to 6	7 to 12	14 to 18	20 & Up	
0 to 10	±3/16	±1/4	±3/16	±1/8	+1/8 -3/16	±3/16	+3/16 -1/4	4
12 to 22	±1/4	±3/8	±1/4	±1/8	+1/8 -3/16	±3/16	+3/16 -1/4	4
24 to 46	±3/8	±1/2	±5/16	+1/8 -3/16	±3/16	+3/16 -1/4	±1/4	4
48 to 70	+3/8 -1/2	+3/4 -1/2	±3/8	±3/16	+3/16 -1/4	±1/4	+1/4 -5/16	5
72 to 144	+3/8 -5/8	+1 -3/4	±1/2	+3/16 -1/4	±1/4	+1/4 -5/16	+1/4 -3/8	5

- 1) All diameters to be measured with a "Pi" tape.
- 2) All linear dimensions to be measured with a steel rule and averaged.
- 3) Bolt line = Actual I.D. + 2 (Average "X" Dimension) + Bolt hole diameter

Mechanical Vibration Reduction

Pipe System Vibration Frequency Hz	Installation in a Piping System					
	Expansion Joint 8" ID X 6" F/F Vibration Reduction At			Rubber Pipe 8" ID X 24" F/F Vibration Reduction At		
	10 PSIG	50 PSIG	80 PSIG	10 PSIG	50 PSIG	80 PSIG
80	37%	55%	72%	87%	91%	93%
68	60%	68%	78%	95%	96%	99%
125	44%	50%	60%	98%	99%	99%
250	44%	50%	50%	96%	97%	99%
500	65%	89%	90%	91%	93%	94%
1000	90%	96%	98%	82%	91%	96%
2000	94%	95%	96%	99%	99%	99%
4000	90%	93%	97%	99%	99%	99%
8000	89%	89%	94%	97%	97%	98%

Example: If an 8" steel piping system had a major vibration frequency of 1000 HZ at 50 PSIG, the percentage of reduction of vibration would be 96% when the expansion joint is installed on the piping system.

Elastomer Maximum Temperature Ratings

Reinforcing Fabric	Tube or Cover Elastomer								
	Pure Gum Rubber	Neo-prene	Butyl	Nitrile	Hypalon®	CSM	EPDM	FKM*	Silicone*
Nylon	180°F/82°C	225°F/107°C	250°F/121°C	210°F/99°C	250°F/121°C	180°F/82°C	250°F/121°C	250°F/121°C	180°F/82°C
Polyester	180°F/82°C	225°F/107°C	250°F/121°C	210°F/99°C	250°F/121°C	250°F/121°C	250°F/121°C	250°F/121°C	250°F/121°C
Aramid	180°F/82°C	225°F/107°C	300°F/149°C	210°F/99°C	250°F/121°C	250°F/121°C	300°F/149°C	400°F/204°C	350°F/177°C

Note: Temperatures listed above are the typical maximum degree ratings for continuous use. All Fabrics lose a percentage of their strength in relation to exposure temperature and duration. Pressure rating is based on 82°C (180°F) operating temperature with a 4:1 safety factor. *Contact Thorburn when higher working temperatures are combined with higher working pressures. Higher operating temperatures may be achieved if operation pressures are reduced and sound engineering practices are used during the design and manufacture of the expansion joint.

Rubber Acoustical Impedance Compared

Material	Sound Velocity (in/sec)	Density (lbs/in³)	Acoustical Impedance (lbs/in² - Sec)	Relative Impedance
Steel	206,500	0.283	58,400	500.0
Copper	140,400	0.320	45,000	425.0
Cast Iron	148,800	0.260	38,700	365.0
Lead	49,800	0.411	20,400	190.0
Glass	216,000	0.094	20,300	190.0
Concrete	198,000	0.072	14,200	134.0
Water	56,400	0.036	2,030	19.0
Pine	132,000	0.0145	1,910	18.0
Cork	19,200	0.0086	165	1.6
Rubber	2,400	0.0442	105	1.0

Acoustical impedance is defined as the product of material density times velocity of sound in that material. In acoustical systems low impedance corresponds to low sound transmission. Relative impedance is based on Rubber = 1.0

Thorburn Expansion Joint Motion Absorbing Capabilities

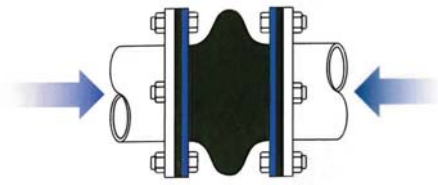

Axial Compression

- Axial movement shortens the face to face dimension along the longitudinal axis
- Pipe flanges remain perpendicular to the longitudinal axis

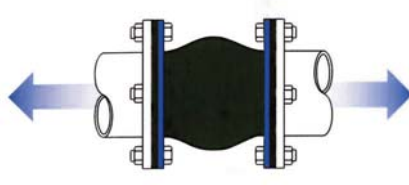

Axial Extension

- Axial movement lengthens the face to face dimension along the longitudinal axis
- Pipe flanges remain perpendicular to the longitudinal axis

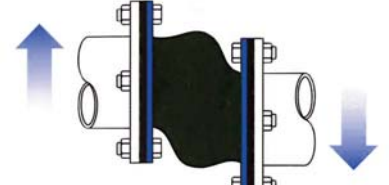

Lateral Deflection

- Offset movement of one or both flanges
- Both flanges remain parallel to each other while forming an angle to the longitudinal expansion joint center line

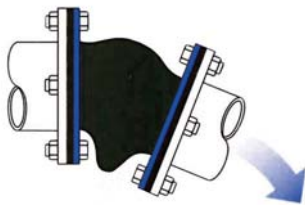

Angular Deflection

- Rotation of one flange relative to the other flange
- One flange remains out of parallel with the other flange and is measured in degrees

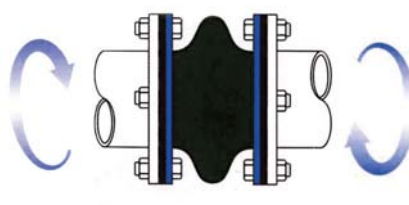

Torsional

- Rotation of one or both flanges in a parallel opposing motion
- Twisting of one flange with respect to the other flange relative to the longitudinal axis and is measured in degrees

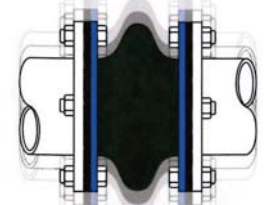

Vibration

- Oscillating movement surrounding the longitudinal axis
- Flanges remain parallel to each other and perpendicular to the longitudinal axis

Thorburn Expansion Joint Typical Arch Profiles

Narrow Arch

42HP • 42HPXX

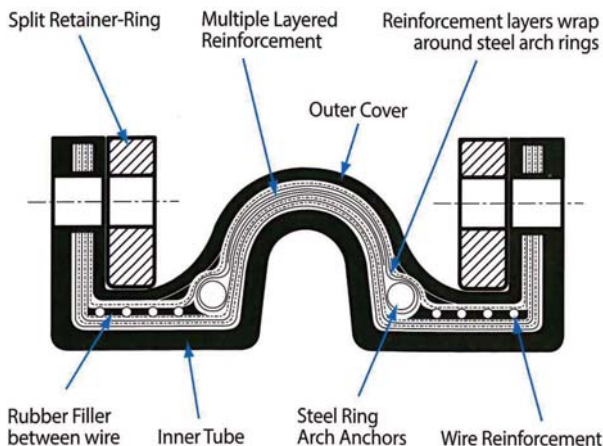

Wide Arch

42HPW • 62HP • 15RA • 30DB

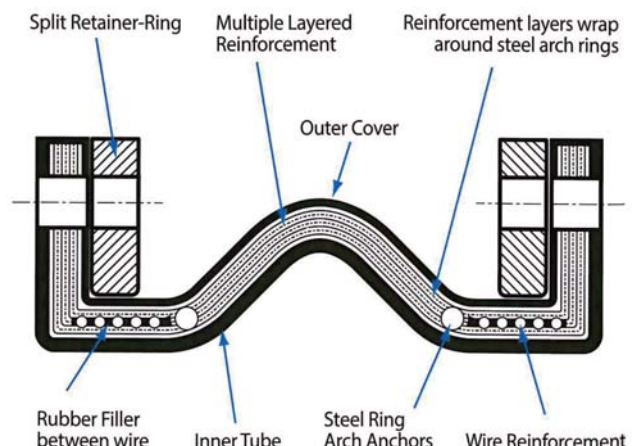

Thorburn Rubber Pressure Piping Expansion Joint Applications



Thorburn was awarded the contract for rubber expansion joints for the Korea Wolsong units 1, 2, 3, & 4 nuclear power stations

Power Generating

- Turbine to condenser
- Condenser circulating water system pump inlet and outlet
- Raw service water pump inlet and outlet
- Mechanical equipment vibration isolation

Petro-Chemical Processing

- Water, acid and chemical thermal movement stress relief
- Absorbs ground settling movement in piping systems
- Water & slurry high pressure pump suction and discharge piping
- Mechanical equipment vibration isolation



Thorburn was awarded the contract for the Syncrude Fort Hills, Canada high pressure slurry rubber piping expansion joints

Material Processing

- Pump suction and discharge lines for water & slurry
- Mechanical equipment vibration isolation
- Fan inlet/outlet thermal and vibration isolation

Marine & Offshore Drilling Rigs

- Fog foam and forced draft piping
- Circulating piping to condenser
- Ventilation piping
- Fire and bilge pump piping
- Mud pump piping
- Overboard discharge
- Fresh water and sea water piping
- Mechanical equipment vibration isolation
- Permanent ballast water secondary containment piping system



Thorburn was awarded the rubber expansion joint contract for the Vale Long Harbour, Nfld., Canada hydrometallurgical nickel plant

Waste Water Sewage Treatment

- Aeration piping
- Raw sewage & sinter sludge ash piping
- Grit & sludge pump piping
- Mechanical equipment vibration isolation

Pulp & Paper

- Process & slurry piping systems
- Heating and cooling systems
- Pump inlet and discharge piping
- Black liquor & white water piping
- Suction box
- Causticizer and digester piping
- Mechanical equipment vibration isolation

Commercial & Institutional Building HVAC

- Air ducts
- Pump suction & discharge
- Circulating water piping
- Compressed air and refrigeration piping



Thorburn was awarded the rubber expansion joint contract for the hibernia offshore oil rig in Newfoundland, Canada

Thorburn's Mighty Spool Rubber Expansion Joint System



Thorburn's 42HPW FEP expansion joints

Flexible Piping System

Thorburn's elastomeric expansion joint and connector piping systems are sections of flexible pipe which are inserted into a rigid piping system. Regardless of materials and construction arrangements, Thorburn's rubber piping expansion joints and connectors are designed to absorb various types of movements in a specified pressure/temperature range.

Thorburn's Mighty Spool rubber expansion joints are capable of absorbing movement in all directions (axial, lateral & angular), unexpected shock, ground settling, thermal and mechanical induced movements caused by pumps, blowers or other rotating equipment.

Sizes from 25mm to 4000mm (1" to 160") and pressures up to 35 bar (500 psi) and full vacuum.

Thorburn's Mighty Spool Features

- Compact to simplify installation
- Eliminates electrolysis between dissimilar metals
- Absorbs movement in all directions
- Doesn't require gaskets
- Compensates for misalignment
- Relieves strain in the piping system
- Reduces mechanical noises

Thorburn's Mighty Spool Advantages

Superior abrasion, erosion & corrosion resistance

- Ideal for sea water, slurry and other abrasive media

Freedom from embrittlement

- Flexing keeps the rubber "alive", eliminates flex induced cracking
- Unlimited flex life

Vibration and sound absorption

- Absorbs transmission of vibration without stress
- Reduces mechanical noises

Great recovery from movement

- Returns to its original position
- Absorbs movement in all directions
- Compensates for misalignment
- Relieves strain in the piping system

High chemical resistance compared to metal

- Eliminates electrolysis between dissimilar metals



Quantity of 36 Thorburn 42HPW 1200mm (48") rubber expansion joints installed at a power plant in Iran



Quantity of 12 Thorburn 62HPW 900mm (36") Rubber Expansion Joints installed on a GRP piping system at a sulphuric acid plant in Baja Mexico



42HP Technical Data

Thorburn's 42HP is a high pressure full vacuum rubber expansion joint. The arch profile is higher and narrower than the 42HPW. The internal reinforcement is made of multiple plies of high tensile calendered aramid fabric, spring steel wire or annular rings in the body of the expansion joint. The flange sealing face is reinforced by integral annular rings which provide a high pressure seal.

- Available in 1, 2, 3 or 4 arches
- FV rating 660mm (26" HG) all sizes
- Hand crafted by skilled builders
- Wide variety of tube/cover compounds
- Designed for high pressure service
- Available in open and filled arch designs

NPS	Face-To-Face			Single Arch Non-Concurrent Design Movement					Single Arch Design Spring Rate Forces				Thrust Factor Effective Area	Working Pressure 4 to 1 Safety Factor
	1 Arch	2 Arches	3 Arches	Axial Compression	Axial Extension	Lateral Deflection	Angular	Torsional	Axial Compression	Axial Extension	Lateral	Angular		
inch	inch	inch	inch	inch	inch	inch	deg	deg	lbf/in	lbf/in	lbf/in	lb*ft/deg	sq.in.	psi
1	6	10	14	0.50	0.25	0.50	27.5	0.5	235	306	353	0.05	9.62	225
1.25	6	10	14	0.50	0.25	0.50	22.5	0.5	294	382	441	0.10	11.04	225
1.5	6	10	14	0.50	0.25	0.50	18.5	0.5	353	459	530	0.15	12.57	225
2	6	10	14	0.50	0.25	0.50	14.5	0.5	423	550	635	0.31	15.90	225
2.5	6	10	14	0.50	0.25	0.50	11.5	0.5	530	689	795	0.51	19.63	225
3	6	10	14	0.50	0.25	0.50	10.0	0.5	675	878	1,013	0.80	23.76	225
4	6	10	14	0.50	0.25	0.50	7.5	0.5	848	1,102	1,272	2	33.2	225
5	6	10	14	0.50	0.25	0.50	6.0	0.5	1,025	1,333	1,538	4	44.2	225
6	6	10	14	0.50	0.25	0.50	5.5	0.5	1,205	1,567	1,808	6	56.7	225
8	6	10	14	0.75	0.38	0.50	5.0	0.5	1,398	1,817	2,097	13	86.6	225
10	8	12	16	0.75	0.38	0.50	4.5	0.5	1,595	2,074	2,393	24	132.7	225
12	8	12	16	0.75	0.38	0.50	3.8	0.5	1,795	2,334	2,693	42	189	225
14	8	12	16	0.75	0.38	0.50	3.3	0.5	2,005	2,607	3,008	59	241	225
16	8	12	16	0.75	0.38	0.50	2.8	0.5	2,215	2,880	3,323	76	299	225
18	8	12	16	0.75	0.38	0.50	2.5	0.5	2,430	3,159	3,645	107	363	225
20	8	12	16	0.88	0.44	0.50	2.5	0.5	2,625	3,413	3,938	152	434	225
22	10	14	18	0.88	0.44	0.50	2.3	0.5	2,815	3,660	4,223	205	531	195
24	10	14	18	0.88	0.44	0.50	2.3	0.5	2,985	3,881	4,478	275	616	195
26	10	14	18	1.00	0.50	0.50	2.3	0.5	3,175	4,128	4,763	292	731	120
28	10	14	18	1.00	0.50	0.50	2.0	0.5	3,376	4,389	5,064	383	830	120
30	10	14	18	1.00	0.50	0.50	2.0	0.5	3,582	4,657	5,373	437	935	120
32	10	14	18	1.00	0.50	0.50	1.8	0.5	3,769	4,900	5,654	556	1,046	100
34	10	14	18	1.00	0.50	0.50	1.8	0.5	4,002	5,203	6,003	645	1,164	100
36	12	14	18	1.00	0.50	0.50	1.5	0.5	4,218	5,483	6,327	844	1,288	100
40	12	14	18	1.00	0.50	0.50	1.5	0.5	4,435	5,766	6,653	1,043	1,555	85
42	12	14	18	1.13	0.56	0.50	1.5	0.5	4,712	6,126	7,068	1,163	1,698	85
48	12	14	18	1.13	0.56	0.50	1.3	0.5	4,987	6,483	7,481	1,825	2,165	85
50	12	14	18	1.13	0.56	0.50	1.3	0.5	5,300	6,890	7,950	1,968	2,333	85
54	12	14	18	1.13	0.56	0.50	1.3	0.5	5,624	7,311	8,436	2,139	2,688	85
56	12	14	18	1.13	0.56	0.50	1.3	0.5	5,986	7,782	8,979	2,308	2,875	85
60	12	14	18	1.13	0.56	0.50	1.0	0.5	6,425	8,353	9,638	3,537	3,267	85
66	12	14	18	1.13	0.56	0.50	1.0	0.5	6,996	9,095	10,494	4,003	3,904	85
72	12	14	18	1.13	0.56	0.50	0.9	0.5	7,632	9,922	11,448	5,681	4,596	85
78	12	16	18	1.13	0.56	0.50	0.9	0.5	8,295	10,784	12,443	6,173	5,411	85
84	12	16	18	1.13	0.56	0.50	0.8	0.5	9,254	12,030	13,881	6,665	6,221	55
96	12	16	18	1.13	0.56	0.50	0.7	0.5	10,176	13,229	15,264	7,650	8,012	55
108	12	16	20	1.13	0.56	0.50	0.6	0.5	11,448	14,882	17,172	8,636	10,029	55
120	12	16	20	1.13	0.56	0.50	0.6	0.5	12,720	16,536	19,080	9,896	12,272	55
132	12	16	20	1.13	0.56	0.50	0.6	0.5	13,992	18,190	20,988	10,886	14,741	55
144	12	16	20	1.13	0.56	0.50	0.5	0.5	15,264	19,843	22,896	11,424	17,437	55

Ordering information see page 82

Special notes on movement capability: 1) Filled arch construction reduces above movements by 50%. 2) To calculate movement of multiple arch type for compression, extension and lateral movements, take movement shown in the above table and multiply by the number of arches. 3) The degree of angular movement is based on the maximum extension shown. 4) Movement capability shown is non-concurrent percentage used in one movement position must be deducted from the other movement position so that sum of movements don't exceed 100%. 5) Movements shown are based on proper installation practices. See Thorburn installation maintenance guide for details.

Special notes on force Pounds / Spring Rates: 1) Forces required to move Thorburn Mighty-Spool Model 42HP are based on zero pressure conditions and room temperature in the pipeline. 2) These forces should be considered only as approximates, compensation must be made for more accurate forces based on materials of construction and actual service conditions. 3) Filled arch spring rates are approximately 4 times that of a single open arch. 4) Multi-arch spring rates are equal to single arch divided by number of arches.



42HPXX Spool Arch Technical Data

Thorburn's 42HPXX is our extra high pressure rubber expansion joint. The arch profile is higher and narrower than the 42HPW. The internal reinforcement is made of multiple plies of high tensile calendered aramid fabric, spring steel wire, annular rings in the body of the expansion joint. External root rings are added for increased pressure support. The flange sealing face is reinforced by integral annular rings which provide a high pressure seal.

- Available in 1, 2, 3 or 4 arches
 - Rated for full vacuum in all sizes
 - Hand crafted by skilled builders
- Wide variety of tube/cover compounds
 - Designed for high pressure service
 - Available in open and filled arch designs

NPS	Face-To-Face			Single Arch Non-Concurrent Design Movement					Single Arch Design Spring Rate Forces				Thrust Factor Effective Area	Working Pressure 4 to 1 Safety Factor
	1 Arch	2 Arches	3 Arches	Axial Compression	Axial Extension	Lateral Deflection	Angular	Torsional	Axial Compression	Axial Extension	Lateral	Angular		
	inch	inch	inch	inch	inch	inch	deg	deg	lb/ft/in	lb/ft/in	lb/ft/in	lb*ft/deg		
1	6	12	16	0.50	0.25	0.50	27.5	0.5	353	459	530	0.08	7.10	300
1.25	6	12	16	0.50	0.25	0.50	22.5	0.5	441	573	662	0.1	8.30	300
1.5	6	12	16	0.50	0.25	0.50	18.5	0.5	530	689	795	0.2	9.60	300
2	6	12	16	0.50	0.25	0.50	14.5	0.5	635	825	953	0.5	12.60	300
2.5	6	12	16	0.50	0.25	0.50	11.5	0.5	795	1,034	1,193	0.8	15.90	300
3	6	12	16	0.50	0.25	0.50	10.0	0.5	1,013	1,317	1,520	1	19.60	300
4	6	12	16	0.50	0.25	0.50	7.5	0.5	1,272	1,653	1,908	3	28.3	300
5	6	12	16	0.50	0.25	0.50	6.0	0.5	1,538	2,000	2,307	6	38.5	300
6	6	12	16	0.50	0.25	0.50	5.5	0.5	1,808	2,351	2,712	10	50.3	300
8	6	12	18	0.75	0.38	0.50	5.0	0.5	2,097	2,725	3,146	19	82.5	300
10	8	16	20	0.75	0.38	0.50	4.5	0.5	2,393	3,111	3,590	36	118	300
12	8	16	20	0.75	0.38	0.50	3.8	0.5	2,693	3,501	4,040	63	159	300
14	8	16	20	0.75	0.38	0.50	3.3	0.5	3,008	3,911	4,512	89	247	300
16	8	16	20	0.75	0.38	0.50	2.8	0.5	3,323	4,320	4,985	114	306	300
18	8	16	20	0.75	0.38	0.50	2.5	0.5	3,645	4,739	5,468	161	372	300
20	8	16	20	0.88	0.44	0.50	2.5	0.5	3,938	5,120	5,907	228	443	300
22	10	16	22	0.88	0.44	0.50	2.3	0.5	4,223	5,490	6,335	308	521	300
24	10	16	22	0.88	0.44	0.50	2.3	0.5	4,478	5,822	6,717	413	605	300
26	10	16	22	1.00	0.50	0.50	2.3	0.5	4,763	6,192	7,145	438	719	250
28	10	16	22	1.00	0.50	0.50	2.0	0.5	5,064	6,584	7,596	575	817	250
30	10	16	22	1.00	0.50	0.50	2.0	0.5	5,373	6,986	8,060	656	921	250
32	10	16	22	1.00	0.50	0.50	1.8	0.5	5,654	7,350	8,481	834	1,032	200
34	10	16	22	1.00	0.50	0.50	1.8	0.5	6,003	7,805	9,005	968	1,149	200
36	10	18	22	1.00	0.50	0.50	1.5	0.5	6,327	8,225	9,491	1,266	1,272	200
40	10	18	22	1.00	0.50	0.50	1.5	0.5	6,653	8,649	9,980	1,565	1,538	200
42	12	18	22	1.13	0.56	0.50	1.5	0.5	7,068	9,189	10,602	1,745	1,698	150
48	12	18	22	1.13	0.56	0.50	1.3	0.5	7,481	9,725	11,222	2,738	2,165	150
50	12	18	22	1.13	0.56	0.50	1.3	0.5	7,950	10,335	11,925	2,952	2,333	150
54	12	18	22	1.13	0.56	0.50	1.3	0.5	8,436	10,967	12,654	3,209	2,688	150
56	12	18	22	1.13	0.56	0.50	1.3	0.5	8,979	11,673	13,469	3,462	2,875	150
60	12	18	22	1.13	0.56	0.50	1.0	0.5	9,638	12,530	14,457	5,306	3,267	150
66	12	18	22	1.13	0.56	0.50	1.0	0.5	10,494	13,643	15,741	6,005	3,904	150
72	12	18	22	1.13	0.56	0.50	0.9	0.5	11,448	14,883	17,172	8,522	4,596	150
78	12	18	22	1.13	0.56	0.50	0.9	0.5	12,443	16,176	18,665	9,260	5,346	150
84	12	18	22	1.13	0.56	0.50	0.8	0.5	13,881	18,045	20,822	9,998	6,186	100
96	12	18	22	1.13	0.56	0.50	0.7	0.5	15,264	19,844	22,896	11,475	7,972	100
108	12	18	22	1.13	0.56	0.50	0.6	0.5	17,172	22,323	25,758	12,954	9,984	100
120	12	18	22	1.13	0.56	0.50	0.6	0.5	19,080	24,804	28,620	14,844	12,223	100
132	12	18	22	1.13	0.56	0.50	0.6	0.5	20,988	27,285	31,482	16,329	14,687	100
144	12	18	22	1.13	0.56	0.50	0.5	0.5	22,896	29,765	34,344	17,136	17,378	100

Ordering information see page 82

Special notes on movement capability: 1) Filled arch construction reduces above movements by 50%. 2) To calculate movement of multiple arch type for compression, extension and lateral movements, take movement shown in the above table and multiply by the number of arches. 3) The degree of angular movement is based on the maximum extension shown. 4) Movement capability shown is non-concurrent percentage used in one movement position must be deducted from the other movement position so that sum of movements don't exceed 100%. 5) Movements shown are based on proper installation practices. See Thorburn installation maintenance guide for details.

Special notes on force Pounds / Spring Rates: 1) Forces required to move Thorburn Mighty-Spool Model 42HPXX are based on zero pressure conditions and room temperature in the pipeline. 2) These forces should be considered only as approximates, compensation must be made for more accurate forces based on materials of construction and actual service conditions. 3) Filled arch spring rates are approximately 4 times that of a single open arch. 4) Multi-arch spring rates are equal to single arch divided by number of arches.

Thorburn's 42HP Reducer Expansion Joints

Concentric, Eccentric, Offset & Enlarged Flange Type



Thorburn's 42HP-CR Concentric & 42HP-OR reducing expansion joints installed in pumping station at the OPG Pickering nuclear reactor



Thorburn's 42HP-ER eccentric reducers
250mm (10") by 100mm (4")

Thorburn's 42HP-CR & 42HP-ER Reducers

Thorburn's 42HP-CR Concentric, 42HP-ER Eccentric Reducers are designed to replace sound transmitting metal pipe reducers. Pipe wall sound that is carried through the piping system is absorbed when passing through Thorburn's rubber reducing expansion joint. Fluid born noise is absorbed by volumetric expansion which cushions water hammer and smoothes out pumping impulses. Mechanical or thermal induced pipe growth/ contraction movements are neutralized by the deflection of the arches.

Thorburn's 42HPOX Offset Reducers

Thorburn's 42HPOX are custom rubber flexible pipes designed to replace rigid piping and absorb axial, lateral and angular movement caused by thermal, mechanical or ground settling.

Thorburn's 42HPOX can be manufactured with custom built-in offsets, non parallel flanges with tangents to connect to existing storage tanks where angular and lateral offsets have occurred. Thorburn's 42HPOX can also be designed with multiple filled arches to provide smooth flow and prevent sediment build-up in the arches.



Thorburn's 42HP-CR Concentric reducer 300mm
(12") by 125mm (5") ID tested at 16 bar

Thorburn's 42HPEF - Enlarged Flange Type

Thorburn's Mighty-Spool Model 42HP-EF utilizes a full faced integral flange design with an enlarged or special drilled flange at the other end. i.e. 8" pipe flange at one end and 12" flange at the other end.



Thorburn's 42HP-OX Offset reducer
300mm (12") by 125mm (5") ID



42HP Reducers Technical Data

Thorburn's Mighty-Spool 42HP-CR Concentric, 42HP-ER Eccentric, 42HPOX Off-set & 42HPEF Enlarged Flange type reducer expansion joints are specifically developed to connect piping of unequalled diameters, offsets and unequalled sized flanges. Thorburn's 42HP reducers are designed to replace and address the limitations found in metallic reducers in a pipeline. The photo on the left shows Thorburn's custom design capabilities to fit varying inside diameters, lengths, flange and movement requirements. The chart below provides standard face-to-face movements and spring rates. Please contact Thorburn with your special application requirements.

NPS		Face-To-Face			Single Arch Non-Concurrent Design Movement					Spring Rate				Thrust Factor Effective Area	Working Pressure 4 to 1 Safety Factor
ID-1	ID-2	1 Arch	2 Arches	3 Arches	Axial Compression	Axial Extension	Lateral Deflection	Angular	Torsional	Axial Compression	Axial Extension	Lateral	Angular		
inch	inch	inch	inch	inch	inch	inch	inch	deg	deg	lb/in	lb/in	lb/in	lb*in/deg	sq.in.	psi
2	1	8	12	16	0.5	0.25	0.5	14	3	423	550	635	0.3	15.90	150
2	1.5	8	12	16	0.5	0.25	0.5	14	3	423	550	635	0.3	15.90	150
2.5	2	8	12	16	0.5	0.25	0.5	11	3	530	689	795	0.5	19.63	150
3	1.5	8	12	16	0.5	0.25	0.5	10	3	675	878	1013	0.8	23.76	150
3	2	8	12	16	0.5	0.25	0.5	10	3	675	878	1013	0.8	23.76	150
3	2.5	8	12	16	0.5	0.25	0.5	10	3	675	878	1013	0.8	23.76	150
4	2	8	12	16	0.5	0.25	0.5	7.5	3	848	1102	1272	2	33.0	150
4	2.5	8	12	16	0.5	0.25	0.5	7.5	3	848	1102	1272	2	33.0	150
4	3	8	12	16	0.5	0.25	0.5	7.5	3	848	1102	1272	2	33.0	150
5	3	8	12	16	0.5	0.25	0.5	6.0	3	1025	1333	1538	4	44.2	150
5	4	8	12	16	0.5	0.25	0.5	6.0	3	1025	1333	1538	4	44.2	150
6	2	8	12	16	0.5	0.25	0.5	5.5	3	1205	1567	1808	6	56.7	150
6	2.5	8	12	16	0.5	0.25	0.5	5.5	3	1205	1567	1808	6	56.7	150
6	3	8	12	16	0.5	0.25	0.5	5.5	3	1205	1567	1808	6	56.7	150
6	4	8	12	16	0.5	0.25	0.5	5.5	3	1205	1567	1808	6	56.7	150
6	5	8	12	16	0.5	0.25	0.5	5.5	3	1205	1567	1808	6	56.7	150
8	3	8	12	16	0.75	0.38	0.5	5.0	3	1398	1817	2097	13	86.6	150
8	4	8	12	16	0.75	0.38	0.5	5.0	3	1398	1817	2097	13	86.6	150
8	5	8	12	16	0.75	0.38	0.5	5.0	3	1398	1817	2097	13	86.6	150
8	6	8	12	16	0.75	0.38	0.5	5.0	3	1398	1817	2097	13	86.6	150
10	5	10	16	20	0.75	0.38	0.5	4.5	3	1595	2074	2393	24	132.7	150
10	6	10	16	20	0.75	0.38	0.5	4.5	3	1595	2074	2393	24	132.7	150
10	8	10	16	20	0.75	0.38	0.5	4.5	3	1595	2074	2393	24	132.7	150
12	6	10	16	20	0.75	0.38	0.5	3.8	3	1795	2334	2693	42	189	150
12	8	10	16	20	0.75	0.38	0.5	3.8	3	1795	2334	2693	42	189	150
12	10	10	16	20	0.75	0.38	0.5	3.8	3	1795	2334	2693	42	189	150
14	8	10	16	20	0.75	0.38	0.5	3.3	2	2005	2607	3008	59	241	150
14	10	10	16	20	0.75	0.38	0.5	3.3	2	2005	2607	3008	59	241	150
14	12	10	16	20	0.75	0.38	0.5	3.3	2	2005	2607	3008	59	241	150
16	10	10	16	20	0.75	0.38	0.5	2.8	2	2215	2880	3323	76	299	150
16	12	10	16	20	0.75	0.38	0.5	2.8	2	2215	2880	3323	76	299	150
16	14	10	16	20	0.75	0.38	0.5	2.8	2	2215	2880	3323	76	299	150
18	12	10	16	20	0.75	0.38	0.5	2.5	1	2430	3159	3645	107	363	150
18	14	10	16	20	0.75	0.38	0.5	2.5	1	2430	3159	3645	107	363	150
18	16	10	16	20	0.75	0.38	0.5	2.5	1	2430	3159	3645	107	363	150
20	14	12	18	22	0.88	0.44	0.5	2.5	1	2652	3413	3938	152	434	150
20	16	12	18	22	0.88	0.44	0.5	2.5	1	2652	3413	3938	152	434	150
20	18	12	18	22	0.88	0.44	0.5	2.5	1	2652	3413	3938	152	434	150
24	20	12	18	22	0.88	0.44	0.5	2.33	1	2985	3881	4478	275	616	110
30	24	12	18	22	1.0	0.5	0.5	2.02	1	3582	4657	5373	437	935	75

Ordering information see page 82

Special notes on movement capability: 1) Filled arch construction reduces above movements by 50%. 2) To calculate movement of multiple arch type for compression, extension and lateral movements, take movement shown in the above table and multiply by the number of arches. 3) The degree of angular movement is based on the maximum extension shown. 4) Movement capability shown is non-concurrent percentage used in one movement position must be deducted from the other movement position so that sum of movements don't exceed 100%. 5) Movements shown are based on proper installation practices. See Thorburn installation maintenance guide for details.

Special notes on force Pounds / Spring Rates: 1) Forces required to move Thorburn Mighty-Spool Model 42HP are based on zero pressure conditions and room temperature in the pipeline. 2) These forces should be considered only as approximates, compensation must be made for more accurate forces based on materials of construction and actual service conditions. 3) Filled arch spring rates are approximately 4 times that of a single open arch. 4) Multi-arch spring rates are equal to single arch divided by number of arches.



42HPW Wide Arch Technical Data

Thorburn's 42HPW is the world's most popular rubber expansion joint, completely re-engineered to do everything a traditional spool type can, while providing improved movement and spring rate capabilities. Primarily used for pressure piping applications and full vacuum service in sizes up to 900mm (36"). Sizes over 900mm full vacuum service is non-standard and require special annular rings (Part #42HPWV).

- Self cleaning wide arch design
- Available in 1, 2, 3 or 4 arches
- Wide variety of tube/cover compounds
- Available in open and filled arch designs
- Double the movement with almost the same length as a standard spool type
- 25% lower spring rate compared to a standard spool type

NPS	Face-To-Face			Single Arch Non-Concurrent Design Movement					Single Arch Design Spring Rate Forces				Thrust Factor Effective Area	Working Pressure 4 to 1 Safety Factor
	1 Arch	2 Arches	3 Arches	Axial Compression	Axial Extension	Lateral Deflection	Angular	Torsional	Axial Compression	Axial Extension	Lateral	Angular		
inch	inch	inch	inch	inch	inch	inch	deg	deg	lbf/in	lbf/in	lbf/in	lb*ft/deg	sq.in.	psi
1	6	12	16	1.75	0.75	0.75	30.0	2.0	176	230	265	0.04	7.10	200
1.25	6	12	16	1.75	0.75	0.75	28.0	2.0	221	287	331	0.08	8.30	200
1.5	6	12	16	1.75	0.75	0.75	26.0	2.0	265	344	398	0.1	9.60	200
2	6	12	16	1.75	0.75	0.75	24.0	2.0	317	413	476	0.2	12.60	200
2.5	6	12	16	1.75	0.75	0.75	22.0	2.0	398	517	596	0.4	15.90	200
3	6	12	16	1.75	0.75	0.75	20.0	2.0	506	659	760	0.6	19.60	200
4	6	12	16	1.75	0.75	0.75	19.0	2.0	636	827	954	1	28.3	200
5	6	12	16	1.75	0.75	0.75	15.0	2.0	769	1,000	1,154	3	38.5	200
6	6	12	16	1.75	0.75	1.00	12.0	2.0	904	1,175	1,356	5	50.3	200
8	6	12	18	1.75	0.75	1.00	10.0	2.0	1,049	1,363	1,573	10	82.5	200
10	8	16	20	1.75	0.75	1.00	9.0	2.0	1,196	1,556	1,795	18	118	200
12	8	16	20	1.75	0.75	1.00	8.0	2.0	1,346	1,751	2,020	32	159	200
14	8	16	20	1.75	0.75	1.00	7.0	2.0	1,504	1,955	2,256	44	247	200
16	8	16	20	1.75	0.75	1.00	6.0	2.0	1,661	2,160	2,492	57	306	200
18	8	16	20	1.75	0.75	1.00	6.0	2.0	1,823	2,369	2,734	80	372	200
20	8	16	20	1.75	0.75	1.00	5.0	2.0	1,969	2,560	2,954	114	443	200
22	10	16	22	1.75	0.75	1.00	5.0	2.0	2,111	2,745	3,167	154	521	175
24	10	16	22	1.75	1.00	1.00	5.0	2.0	2,239	2,911	3,359	206	605	175
26	10	16	22	1.75	1.00	1.00	4.0	2.0	2,381	3,096	3,572	219	719	110
28	10	16	22	1.75	1.00	1.00	4.0	2.0	2,532	3,292	3,798	287	817	110
30	10	16	22	1.75	1.00	1.00	4.0	2.0	2,687	3,493	4,030	328	921	110
32	10	16	22	1.75	1.00	1.00	4.0	2.0	2,827	3,675	4,241	417	1,032	90
34	10	16	22	1.75	1.00	1.00	3.0	2.0	3,002	3,902	4,502	484	1,149	90
36	10	18	22	2.25	1.00	1.00	3.0	2.0	3,164	4,112	4,745	633	1,272	90
40	10	18	22	2.25	1.00	1.00	3.0	2.0	3,326	4,325	4,990	782	1,538	75
42	12	18	22	2.25	1.00	1.00	3.0	2.0	3,534	4,595	5,301	872	1,698	75
48	12	18	22	2.25	1.00	1.00	3.0	2.0	3,740	4,862	5,611	1,369	2,165	75
50	12	18	22	2.25	1.00	1.00	3.0	2.0	3,975	5,168	5,963	1,476	2,333	75
54	12	18	22	2.25	1.25	1.00	3.0	2.0	4,218	5,483	6,327	1,604	2,688	75
56	12	18	22	2.25	1.25	1.00	2.0	2.0	4,490	5,837	6,734	1,731	2,875	75
60	12	18	22	2.25	1.25	1.00	2.0	2.0	4,819	6,265	7,229	2,653	3,267	75
66	12	18	22	2.25	1.25	1.00	2.0	2.0	5,247	6,821	7,871	3,002	3,904	75
72	12	18	22	2.25	1.25	1.00	2.0	2.0	5,724	7,442	8,586	4,261	4,596	75
78	12	18	22	2.25	1.25	1.00	1.0	2.0	6,221	8,088	9,332	4,630	5,346	75
84	12	18	22	2.25	1.25	1.00	1.0	2.0	6,941	9,023	10,411	4,999	6,186	50
96	12	18	22	2.25	1.25	1.00	1.0	2.0	7,632	9,922	11,448	5,738	7,972	50
108	12	18	22	2.25	1.25	1.00	1.0	2.0	8,586	11,162	12,879	6,477	9,984	50
120	12	18	22	2.25	1.25	1.00	1.0	2.0	9,540	12,402	14,310	7,422	12,223	50
132	12	18	22	2.25	1.25	1.00	1.0	2.0	10,494	13,643	15,741	8,165	14,687	50
144	12	18	22	2.25	1.25	1.00	1.0	2.0	11,448	14,882	17,172	8,568	17,376	50

NOTE: Sizes DIN 1050 (42") and above, when full vacuum (26"Hg) is required please use Thorburn Part # 42HPWV **Ordering information see page 82**

Special notes on movement capability: 1) Filled arch construction reduces above movements by 50%. 2) To calculate movement of multiple arch type for compression, extension and lateral movements, take movement shown in the above table and multiply by the number of arches. 3) The degree of angular movement is based on the maximum extension shown. 4) Movement capability shown is non-concurrent percentage used in one movement position must be deducted from the other movement position so that sum of movements don't exceed 100%. 5) Movements shown are based on proper installation practices. See Thorburn installation maintenance guide for details.

Special notes on force Pounds / Spring Rates: 1) Forces required to move Thorburn Mighty-Spool Model 42HPW are based on zero pressure conditions and room temperature in the pipeline. 2) These forces should be considered only as approximates, compensation must be made for more accurate forces based on materials of construction and actual service conditions. 3) Filled arch spring rates are approximately 4 times that of a single open arch. 4) Multi-arch spring rates are equal to single arch divided by number of arches.



42HPWP Series PTFE/FEP Technical Data

Thorburn's 42HPWP Series PTFE/FEP lined rubber expansion joints are specifically designed to resist corrosive attack from chemically charged media at high temperatures and pressures. Custom designs for greater movements available upon request.

- Non-stick, self cleaning wide arch design
- Available in 1, 2, 3 or 4 arches
- Rated for full vacuum in all sizes
- Hand crafted by skilled builders
- Double the movement with the same overall length as a standard spool type
- 25% lower spring rate compared to a standard spool type
- Available with PTFE/FEP top hat liner for smooth flow

NPS	Face-To-Face			Single Arch Non-Concurrent Design Movements					Spring Rate				Thrust Factor Effective Area	Working Pressure 4 to 1 Safety Factor
	1 Arch	2 Arches	3 Arches	Axial Compression	Axial Extension	Lateral Deflection	Angular	Torsional	Axial Compression	Axial Extension	Lateral	Angular		
inch	inch	inch	inch	inch	inch	inch	deg	deg	lb/in	lb/in	lb/in	lb*in/deg	sq.in.	psi
1	6	12	16	1.75	0.75	0.75	30.0	2.0	176	230	265	0.04	7.10	200
1.25	6	12	16	1.75	0.75	0.75	28.0	2.0	221	287	331	0.08	8.30	200
1.5	6	12	16	1.75	0.75	0.75	26.0	2.0	265	344	398	0.1	9.60	200
2	6	12	16	1.75	0.75	0.75	24.0	2.0	317	413	476	0.2	12.60	200
2.5	6	12	16	1.75	0.75	0.75	22.0	2.0	398	517	596	0.4	15.90	200
3	6	12	16	1.75	0.75	0.75	20.0	2.0	506	659	760	0.6	19.60	200
4	6	12	16	1.75	0.75	0.75	19.0	2.0	636	827	954	1	28.3	200
5	6	12	16	1.75	0.75	0.75	15.0	2.0	769	1,000	1,154	3	38.5	200
6	6	12	16	1.75	0.75	1.00	12.0	2.0	904	1,175	1,356	5	50.3	200
8	6	12	18	1.75	0.75	1.00	10.0	2.0	1,049	1,363	1,573	10	82.5	200
10	8	16	20	1.75	0.75	1.00	9.0	2.0	1,196	1,556	1,795	18	118	200
12	8	16	20	1.75	0.75	1.00	8.0	2.0	1,346	1,751	2,020	32	159	200
14	8	16	20	1.75	0.75	1.00	7.0	2.0	1,504	1,955	2,256	44	247	200
16	8	16	20	1.75	0.75	1.00	6.0	2.0	1,661	2,160	2,492	57	306	200
18	8	16	20	1.75	0.75	1.00	6.0	2.0	1,823	2,369	2,734	80	372	200
20	8	16	20	1.75	0.75	1.00	5.0	2.0	1,969	2,560	2,954	114	443	200
22	10	16	22	1.75	0.75	1.00	5.0	2.0	2,111	2,745	3,167	154	521	175
24	10	16	22	1.75	1.00	1.00	5.0	2.0	2,239	2,911	3,359	206	605	175
26	10	16	22	1.75	1.00	1.00	4.0	2.0	2,381	3,096	3,572	219	719	110
28	10	16	22	1.75	1.00	1.00	4.0	2.0	2,532	3,292	3,798	287	817	110
30	10	16	22	1.75	1.00	1.00	4.0	2.0	2,687	3,493	4,030	328	921	110
32	10	16	22	1.75	1.00	1.00	4.0	2.0	2,827	3,675	4,241	417	1,032	90
34	10	16	22	1.75	1.00	1.00	3.0	2.0	3,002	3,902	4,502	484	1,149	90
36	10	18	22	2.25	1.00	1.00	3.0	2.0	3,164	4,112	4,745	633	1,272	90
40	10	18	22	2.25	1.00	1.00	3.0	2.0	3,326	4,325	4,990	782	1,538	75
42	12	18	22	2.25	1.00	1.00	3.0	2.0	3,534	4,595	5,301	872	1,698	75
48	12	18	22	2.25	1.00	1.00	3.0	2.0	3,740	4,862	5,611	1,369	2,165	75
50	12	18	22	2.25	1.00	1.00	3.0	2.0	3,975	5,168	5,963	1,476	2,333	75
54	12	18	22	2.25	1.25	1.00	3.0	2.0	4,218	5,483	6,327	1,604	2,688	75
56	12	18	22	2.25	1.25	1.00	2.0	2.0	4,490	5,837	6,734	1,731	2,875	75
60	12	18	22	2.25	1.25	1.00	2.0	2.0	4,819	6,265	7,229	2,653	3,267	75
66	12	18	22	2.25	1.25	1.00	2.0	2.0	5,247	6,821	7,871	3,002	3,904	75
72	12	18	22	2.25	1.25	1.00	2.0	2.0	5,724	7,442	8,586	4,261	4,596	75
78	12	18	22	2.25	1.25	1.00	1.0	2.0	6,221	8,088	9,332	4,630	5,346	75
84	12	18	22	2.25	1.25	1.00	1.0	2.0	6,941	9,023	10,411	4,999	6,186	50
96	12	18	22	2.25	1.25	1.00	1.0	2.0	7,632	9,922	11,448	5,738	7,972	50
108	12	18	22	2.25	1.25	1.00	1.0	2.0	8,586	11,162	12,879	6,477	9,984	50
120	12	18	22	2.25	1.25	1.00	1.0	2.0	9,540	12,402	14,310	7,422	12,223	50
132	12	18	22	2.25	1.25	1.00	1.0	2.0	10,494	13,643	15,741	8,165	14,687	50
144	12	18	22	2.25	1.25	1.00	1.0	2.0	11,448	14,882	17,172	8,568	17,378	50

Ordering information see page 82

Special notes on movement capability: 1) To calculate movement of multiple arch type for compression, extension and lateral movements, take movement shown in the above table and multiply by the number of arches. 2) The degree of angular movement is based on the maximum extension shown. 2) Movement capability shown is non-concurrent percentage used in one movement position and must be deducted from the other movement position so that sum of movements don't exceed 100%. 4) Movements shown are based on proper installation practices. See Thorburn installation maintenance guide for details.

Special notes on force Pounds / Spring Rates: 1) Forces required to move Thorburn Mighty-Spool Model 42HPWP PTFE/FEP Lined are based on zero pressure conditions and room temperature in the pipeline. 2) These forces should be considered only as approximates, compensation must be made for more accurate forces based on materials of construction and actual service conditions. 3) Multi-arch spring rates are equal to single arch divided by number of arches.



62HP Wide Arch Series Technical Data

Thorburn's 62HP is specifically designed for plastic, glass & FRP piping systems where low reaction forces and large movements are required.

- Self cleaning wide arch design
- Available in 1, 2, 3 or 4 arches
- Wide variety of tube/cover compounds
- Double the movement with the same overall length as a standard spool type
- 60% lower spring rate compared to a standard spool type
- Available in open and filled arch designs

NPS	Face-To-Face			Single Arch Non-Concurrent Design Movement					Spring Rate				Thrust Factor Effective Area	Working Pressure 4 to 1 Safety Factor
	1 Arch	2 Arches	3 Arches	Axial Compression	Axial Extension	Lateral Deflection	Angular	Torsional	Axial Compression	Axial Extension	Lateral	Angular		
inch	inch	inch	inch	inch	inch	inch	deg	deg	lbf/in	lbf/in	lbf/in	lb*ft/deg	sq.in.	psi
1	6	12	16	1.75	0.75	0.75	30.0	2.0	94	122	141	0.02	14.25	100
1.25	6	12	16	1.75	0.75	0.75	28.0	2.0	118	153	176	0.04	15.98	100
1.5	6	12	16	1.75	0.75	0.75	26.0	2.0	141	184	212	0.06	17.80	100
2	6	12	16	1.75	0.75	0.75	24.0	2.0	169	220	254	0.12	21.73	100
2.5	6	12	16	1.75	0.75	0.75	22.0	2.0	212	276	318	0.2	26.06	100
3	6	12	16	1.75	0.75	0.75	20.0	2.0	270	351	405	0.3	30.78	100
4	6	12	16	1.75	0.75	0.75	19.0	2.0	339	441	509	0.8	41.4	100
5	6	12	16	1.75	0.75	0.75	15.0	2.0	410	533	615	1.5	53.6	100
6	6	12	16	1.75	0.75	1.00	12.0	2.0	482	627	723	2.6	67.3	100
8	6	12	18	1.75	0.75	1.00	10.0	2.0	559	727	839	5.1	103.9	100
10	8	16	20	1.75	0.75	1.00	9.0	2.0	638	830	957	9.7	143.1	100
12	8	16	20	1.75	0.75	1.00	8.0	2.0	718	934	1,077	17	189	100
14	8	16	20	1.75	0.75	1.00	7.0	2.0	802	1,043	1,203	24	284	100
16	8	16	20	1.75	0.75	1.00	6.0	2.0	886	1,152	1,329	30	346	100
18	8	16	20	1.75	0.75	1.00	6.0	2.0	972	1,264	1,458	43	415	100
20	8	16	20	1.75	0.75	1.00	5.0	2.0	1,050	1,365	1,575	61	491	100
22	10	16	22	1.75	0.75	1.00	5.0	2.0	1,126	1,464	1,689	82	573	100
24	10	16	22	1.75	1.00	1.00	5.0	2.0	1,194	1,552	1,791	110	661	75
26	10	16	22	1.75	1.00	1.00	4.0	2.0	1,270	1,651	1,905	117	779	75
28	10	16	22	1.75	1.00	1.00	4.0	2.0	1,350	1,756	2,026	153	881	50
30	10	16	22	1.75	1.00	1.00	4.0	2.0	1,433	1,863	2,149	175	990	50
32	10	16	22	1.75	1.00	1.00	4.0	2.0	1,508	1,960	2,262	222	1,104	50
34	10	16	22	1.75	1.00	1.00	3.0	2.0	1,601	2,081	2,401	258	1,225	50
36	10	18	22	2.25	1.00	1.00	3.0	2.0	1,687	2,193	2,531	338	1,353	50
40	10	18	22	2.25	1.00	1.00	3.0	2.0	1,774	2,306	2,661	417	1,626	50
42	12	18	22	2.25	1.00	1.00	3.0	2.0	1,885	2,450	2,827	465	1,792	50
48	12	18	22	2.25	1.00	1.00	3.0	2.0	1,995	2,593	2,992	730	2,270	50
50	12	18	22	2.25	1.00	1.00	3.0	2.0	2,120	2,756	3,180	787	2,442	50
54	12	18	22	2.25	1.25	1.00	3.0	2.0	2,250	2,924	3,374	856	2,805	50
56	12	18	22	2.25	1.25	1.00	2.0	2.0	2,394	3,113	3,592	923	2,996	50
60	12	18	22	2.25	1.25	1.00	2.0	2.0	2,570	3,341	3,855	1,415	3,396	50
66	12	18	22	2.25	1.25	1.00	2.0	2.0	2,798	3,638	4,198	1,601	4,044	50
72	12	18	22	2.25	1.25	1.00	2.0	2.0	3,053	3,969	4,579	2,272	4,749	50
78	12	18	22	2.25	1.25	1.00	1.0	2.0	3,318	4,314	4,977	2,469	5,510	50
84	12	18	22	2.25	1.25	1.00	1.0	2.0	3,702	4,812	5,552	2,666	6,362	33
96	12	18	22	2.25	1.25	1.00	1.0	2.0	4,070	5,292	6,106	3,060	8,171	33
108	12	18	22	2.25	1.25	1.00	1.0	2.0	4,579	5,953	6,869	3,454	10,207	33
120	12	18	22	2.25	1.25	1.00	1.0	2.0	5,088	6,614	7,632	3,958	12,469	33
132	12	18	22	2.25	1.25	1.00	1.0	2.0	5,597	7,276	8,395	4,354	14,957	33
144	12	18	22	2.25	1.25	1.00	1.0	2.0	6,106	7,937	9,158	4,570	17,671	33

Ordering information see page 82

Special notes on movement capability: 1) Filled arch construction reduces above movements by 50%. 2) To calculate movement of multiple arch type for compression, extension and lateral movements, take movement shown in the above table and multiply by the number of arches. 3) The degree of angular movement is based on the maximum extension shown. 4) Movement capability shown is non-concurrent percentage used in one movement position must be deducted from the other movement position so that sum of movements don't exceed 100%. 5) Movements shown are based on proper installation practices. See Thorburn installation maintenance guide for details.

Special notes on force Pounds / Spring Rates: 1) Forces required to move Thorburn Mighty-Spool Model 62HP are based on zero pressure conditions and room temperature in the pipeline. 2) These forces should be considered only as approximates, compensation must be made for more accurate forces based on materials of construction and actual service conditions. 3) Filled arch spring rates are approximately 4 times that of a single open arch. 4) Multi-arch spring rates are equal to single arch divided by number of arches.



62HPVX Wide Arch Series Technical Data

Thorburn's 62HPVX is similar to Thorburn Model 62HP and is used applications that require full vacuum and higher pressures. Designed for plastic, glass & FRP piping systems where low reaction forces and large movements are required.

- Self cleaning wide arch design
- Available in 1, 2, 3 or 4 arches
- Wide variety of tube/cover compounds
- Double the movement with the same overall length as a standard spool type
- 50% lower spring rate compared to a standard spool type
- Available in open and filled arch designs

NPS	Face-To-Face			Single Arch Non-Concurrent Design Movement					Spring Rate				Thrust Factor Effective Area	Working Pressure 4 to 1 Safety Factor
	1 Arch	2 Arches	3 Arches	Axial Compression	Axial Extension	Lateral Deflection	Angular	Torsional	Axial Compression	Axial Extension	Lateral	Angular		
inch	inch	inch	inch	inch	inch	inch	deg	deg	lbf/in	lbf/in	lbf/in	lb*ft/deg	sq.in.	psi
1	6	12	16	1.75	0.75	0.75	30.0	2.0	118	153	177	0.03	14.25	150
1.25	6	12	16	1.75	0.75	0.75	28.0	2.0	147	191	221	0.05	15.98	150
1.5	6	12	16	1.75	0.75	0.75	26.0	2.0	177	230	265	0.08	17.80	150
2	6	12	16	1.75	0.75	0.75	24.0	2.0	212	275	318	0.2	21.73	150
2.5	6	12	16	1.75	0.75	0.75	22.0	2.0	265	345	398	0.3	26.06	150
3	6	12	16	1.75	0.75	0.75	20.0	2.0	338	439	507	0.4	30.78	150
4	6	12	16	1.75	0.75	0.75	19.0	2.0	424	551	636	1	41.4	150
5	6	12	16	1.75	0.75	0.75	15.0	2.0	513	667	769	2	53.6	150
6	6	12	16	1.75	0.75	1.00	12.0	2.0	603	784	904	3	67.3	150
8	6	12	18	1.75	0.75	1.00	10.0	2.0	699	909	1,049	6	103.9	150
10	8	16	20	1.75	0.75	1.00	9.0	2.0	798	1,037	1,197	12	143.1	150
12	8	16	20	1.75	0.75	1.00	8.0	2.0	898	1,167	1,347	21	189	150
14	8	16	20	1.75	0.75	1.00	7.0	2.0	1,003	1,304	1,504	30	284	150
16	8	16	20	1.75	0.75	1.00	6.0	2.0	1,108	1,440	1,662	38	346	150
18	8	16	20	1.75	0.75	1.00	6.0	2.0	1,215	1,580	1,823	54	415	150
20	8	16	20	1.75	0.75	1.00	5.0	2.0	1,313	1,707	1,969	76	491	150
22	10	16	22	1.75	0.75	1.00	5.0	2.0	1,408	1,830	2,112	103	573	130
24	10	16	22	1.75	1.00	1.00	5.0	2.0	1,493	1,941	2,239	138	661	130
26	10	16	22	1.75	1.00	1.00	4.0	2.0	1,588	2,064	2,382	146	779	80
28	10	16	22	1.75	1.00	1.00	4.0	2.0	1,688	2,195	2,532	192	881	80
30	10	16	22	1.75	1.00	1.00	4.0	2.0	1,791	2,329	2,687	218	990	80
32	10	16	22	1.75	1.00	1.00	4.0	2.0	1,885	2,450	2,827	278	1,104	68
34	10	16	22	1.75	1.00	1.00	3.0	2.0	2,001	2,602	3,002	323	1,225	68
36	10	18	22	2.25	1.00	1.00	3.0	2.0	2,109	2,742	3,164	422	1,353	68
40	10	18	22	2.25	1.00	1.00	3.0	2.0	2,218	2,883	3,327	522	1,626	56
42	12	18	22	2.25	1.00	1.00	3.0	2.0	2,356	3,063	3,534	582	1,792	56
48	12	18	22	2.25	1.00	1.00	3.0	2.0	2,494	3,242	3,741	913	2,270	56
50	12	18	22	2.25	1.00	1.00	3.0	2.0	2,650	3,445	3,975	984	2,442	56
54	12	18	22	2.25	1.25	1.00	3.0	2.0	2,812	3,656	4,218	1,070	2,805	56
56	12	18	22	2.25	1.25	1.00	2.0	2.0	2,993	3,891	4,490	1,154	2,996	56
60	12	18	22	2.25	1.25	1.00	2.0	2.0	3,213	4,177	4,819	1,769	3,396	56
66	12	18	22	2.25	1.25	1.00	2.0	2.0	3,498	4,548	5,247	2,002	4,044	56
72	12	18	22	2.25	1.25	1.00	2.0	2.0	3,816	4,961	5,724	2,841	4,749	56
78	12	18	22	2.25	1.25	1.00	1.0	2.0	4,148	5,392	6,222	3,087	5,510	56
84	12	18	22	2.25	1.25	1.00	1.0	2.0	4,627	6,015	6,941	3,333	6,362	38
96	12	18	22	2.25	1.25	1.00	1.0	2.0	5,088	6,615	7,632	3,825	8,171	38
108	12	18	22	2.25	1.25	1.00	1.0	2.0	5,724	7,441	8,586	4,318	10,207	38
120	12	18	22	2.25	1.25	1.00	1.0	2.0	6,360	8,268	9,540	4,948	12,469	38
132	12	18	22	2.25	1.25	1.00	1.0	2.0	6,996	9,095	10,494	5,443	14,957	38
144	12	18	22	2.25	1.25	1.00	1.0	2.0	7,632	9,922	11,448	5,712	17,671	38

Ordering information see page 82

Special notes on movement capability: 1) Filled arch construction reduces above movements by 50%. 2) To calculate movement of multiple arch type for compression, extension and lateral movements, take movement shown in the above table and multiply by the number of arches. 3) The degree of angular movement is based on the maximum extension shown. 4) Movement capability shown is non-concurrent percentage used in one movement position must be deducted from the other movement position so that sum of movements don't exceed 100%. 5) Movements shown are based on proper installation practices. See Thorburn installation maintenance guide for details.

Special notes on force Pounds / Spring Rates: 1) Forces required to move Thorburn Mighty-Spool Model 62HPVX are based on zero pressure conditions and room temperature in the pipeline. 2) These forces should be considered only as approximates, compensation must be made for more accurate forces based on materials of construction and actual service conditions. 3) Filled arch spring rates are approximately 4 times that of a single open arch. 4) Multi-arch spring rates are equal to single arch divided by number of arches.

62HPWXX Wide Arch Rubber Expansion Joint

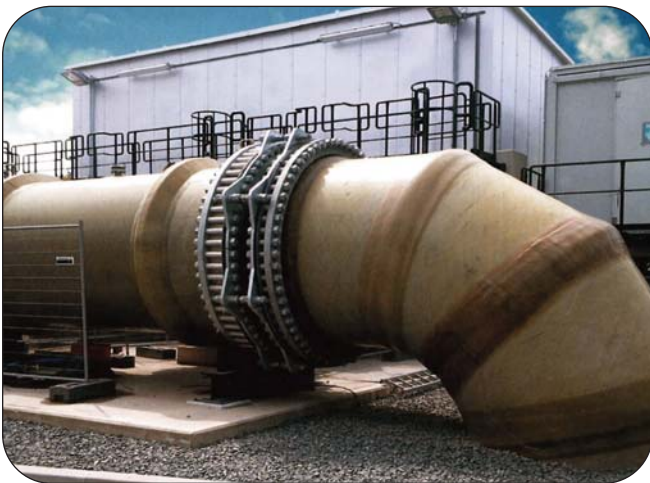

Thorburn's 62HPWXX with integral one piece (no split) backing flange installed in an FRP piping system

62HPWXX expansion joint with integral backing (one piece - no split) flange

Thorburn's 62HPWXX is specifically designed for plastic & FRP piping systems where low reaction forces and large movements are required. Its integral control rod system eliminates problematic bending loads on FRP flanges. Integral backing rings makes it easy to install and simplifies bolt up.

- Custom designed to suit application
- Available with DIN or ANSI flange bolting
- Diameters from DIN 25 (1") to DIN 3600 (144")
- Designed for high pressure FRP piping systems
- Full vacuum rating for all sizes
- Customized face-to-face dimensions available
- Absorbs noise , vibration & shock
- Compensates for minor misalignment and offsets
- Excellent chemical, ozone & abrasion resistance



Thorburn's DIN 2800 62HPWXX expansion joints with integral one piece (no split) backing flange

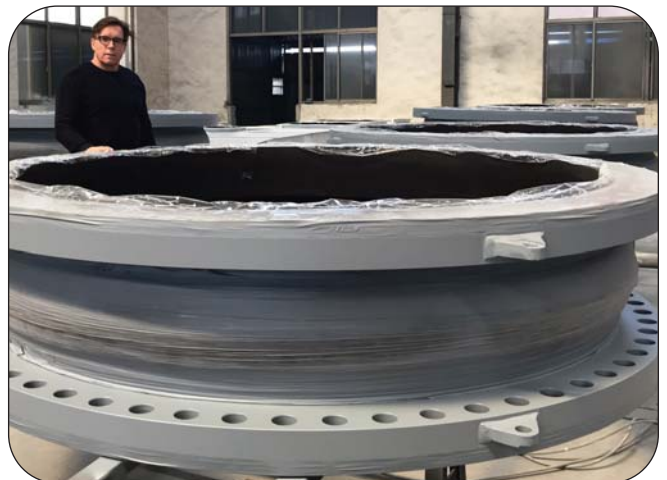

Thorburn's 62HPWXX high pressure DIN 2000 expansion joint for 25 bar pressure service with 4 to 1 safety factor

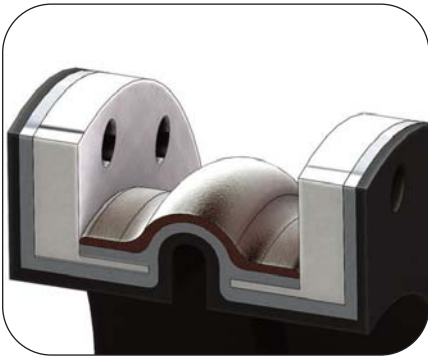

Illustration of backing flange with integral tangent rings

62HPWXX Wide Arch Technical Data

Thorburn's 62HPWXX is an extra wide arch expansion joint with an integral embedded heavy duty one piece no split backing flange with "L" shaped tangent rings. It allows for higher compressive forces to facilitate flange sealing at high pressures.

- Self cleaning wide arch design
- Available in 1, 2, 3 or 4 arches
- Wide variety of tube/cover compounds
- Double the movement with almost the same length as a standard spool type
- Can be modified for use as a dismantling joint to simplify installation of equipment
- 40% lower spring rates compared to a 42HPXX spool type expansion joint.
- Available in open and filled arch designs

NPS	Face-To-Face			Single Arch Non-Concurrent Design Movement					Single Arch Design Spring Rate Forces				Thrust Factor Effective Area	Working Pressure 4 to 1 Safety Factor
	1 Arch	2 Arches	3 Arches	Axial Compression	Axial Extension	Lateral Deflection	Angular	Torsional	Axial Compression	Axial Extension	Lateral	Angular		
inch	inch	inch	inch	inch	inch	inch	deg	deg	lbf/in	lbf/in	lbf/in	lb*ft/deg	sq.in.	psi
1	6	12	18	1.75	0.75	0.75	30.0	2.0	212	275	318	0.05	7.10	300
1.25	6	12	18	1.75	0.75	0.75	28.0	2.0	265	344	397	0.09	8.30	300
1.5	6	12	18	1.75	0.75	0.75	26.0	2.0	318	413	477	0.1	9.60	300
2	6	12	18	1.75	0.75	0.75	24.0	2.0	381	495	572	0.3	12.60	300
2.5	6	12	18	1.75	0.75	0.75	22.0	2.0	477	620	716	0.5	15.90	300
3	6	12	18	1.75	0.75	0.75	20.0	2.0	608	790	912	0.7	19.60	300
4	8	14	20	1.75	0.75	0.75	19.0	2.0	763	992	1,145	2	28.3	300
5	8	14	20	1.75	0.75	0.75	15.0	2.0	923	1,200	1,384	3	38.5	300
6	8	14	20	1.75	0.75	1.00	12.0	2.0	1,085	1,410	1,627	6	50.3	300
8	8	14	20	1.75	0.75	1.00	10.0	2.0	1,258	1,635	1,888	12	82.5	300
10	8	14	20	1.75	0.75	1.00	9.0	2.0	1,436	1,867	2,154	22	118	300
12	8	14	20	1.75	0.75	1.00	8.0	2.0	1,616	2,101	2,424	38	159	300
14	10	16	22	1.75	0.75	1.00	7.0	2.0	1,805	2,346	2,707	53	247	300
16	10	16	22	1.75	0.75	1.00	6.0	2.0	1,994	2,592	2,991	68	306	300
18	10	16	22	1.75	0.75	1.00	6.0	2.0	2,187	2,843	3,281	97	372	300
20	10	16	22	1.75	0.75	1.00	5.0	2.0	2,363	3,072	3,544	137	443	300
22	12	18	24	1.75	0.75	1.00	5.0	2.0	2,534	3,294	3,801	185	521	300
24	12	18	24	1.75	1.00	1.00	5.0	2.0	2,687	3,493	4,030	248	605	300
26	12	18	24	1.75	1.00	1.00	4.0	2.0	2,858	3,715	4,287	263	719	250
28	12	18	24	1.75	1.00	1.00	4.0	2.0	3,038	3,950	4,558	345	817	250
30	12	18	24	1.75	1.00	1.00	4.0	2.0	3,224	4,191	4,836	394	921	250
32	16	22	28	1.75	1.00	1.00	4.0	2.0	3,392	4,410	5,089	500	1,032	250
34	16	22	28	1.75	1.00	1.00	3.0	2.0	3,602	4,683	5,403	581	1,149	250
36	16	22	28	2.25	1.00	1.00	3.0	2.0	3,796	4,935	5,695	760	1,272	250
40	16	22	28	2.25	1.00	1.00	3.0	2.0	3,992	5,189	5,988	939	1,538	250
42	18	24	30	2.25	1.00	1.00	3.0	2.0	4,241	5,513	6,361	1,047	1,698	250
48	18	24	30	2.25	1.00	1.00	3.0	2.0	4,488	5,835	6,733	1,643	2,165	250
50	18	24	30	2.25	1.00	1.00	3.0	2.0	4,770	6,201	7,155	1,771	2,333	250
54	18	24	30	2.25	1.25	1.00	3.0	2.0	5,062	6,580	7,592	1,925	2,688	250
56	18	24	30	2.25	1.25	1.00	2.0	2.0	5,387	7,004	8,081	2,077	2,875	250
60	20	26	32	2.25	1.25	1.00	2.0	2.0	5,783	7,518	8,674	3,184	3,267	250
66	20	26	32	2.25	1.25	1.00	2.0	2.0	6,296	8,186	9,445	3,603	3,904	250
72	20	26	32	2.25	1.25	1.00	2.0	2.0	6,869	8,930	10,303	5,113	4,596	250
78	20	26	32	2.25	1.25	1.00	1.0	2.0	7,466	9,706	11,199	5,556	5,346	250
84	22	28	34	2.25	1.25	1.00	1.0	2.0	8,329	10,827	12,493	5,999	6,186	250
96	22	28	34	2.25	1.25	1.00	1.0	2.0	9,158	11,906	13,738	6,885	7,972	150
108	22	28	34	2.25	1.25	1.00	1.0	2.0	10,303	13,394	15,455	7,772	9,984	150
120	22	28	34	2.25	1.25	1.00	1.0	2.0	11,448	14,882	17,172	8,906	12,223	150
132	22	28	34	2.25	1.25	1.00	1.0	2.0	12,593	16,371	18,889	9,797	14,687	150
144	22	28	34	2.25	1.25	1.00	1.0	2.0	13,738	17,859	20,606	10,282	17,376	150

Ordering information see page 82

Special notes on movement capability: 1) Filled arch construction reduces above movements by 50%. 2) To calculate movement of multiple arch type for compression, extension and lateral movements, take movement shown in the above table and multiply by the number of arches. 3) The degree of angular movement is based on the maximum extension shown. 4) Movement capability shown is non-concurrent percentage used in one movement position must be deducted from the other movement position so that sum of movements don't exceed 100%. 5) Movements shown are based on proper installation practices. See Thorburn installation maintenance guide for details.

Special notes on force Pounds / Spring Rates: 1) Forces required to move Thorburn Mighty-Spool Model 62HPWXX are based on zero pressure conditions and room temperature in the pipeline. 2) These forces should be considered only as approximates, compensation must be made for more accurate forces based on materials of construction and actual service conditions. 3) Filled arch spring rates are approximately 4 times that of a single open arch. 4) Multi-arch spring rates are equal to single arch divided by number of arches.

Thorburn 30DB Sleeve Type Expansion Joint



Thorburn's Mighty-Spool 30DB are custom fabricated expansion joints made in a single open, filled and/or multi-arch design. Mighty-Spool 30DB are specifically designed for low pressure piping applications where a higher pressure flange is not required. The cuffs are designed to fit over the end of a pipe and are secured by the use of one or more bolted clamps.

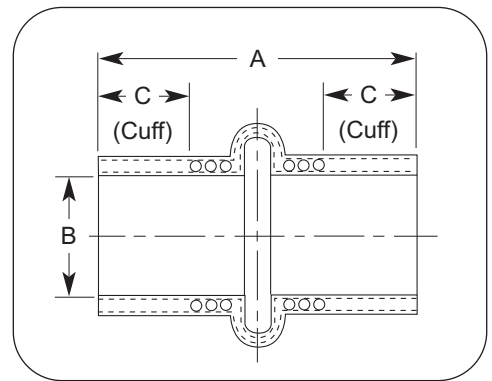
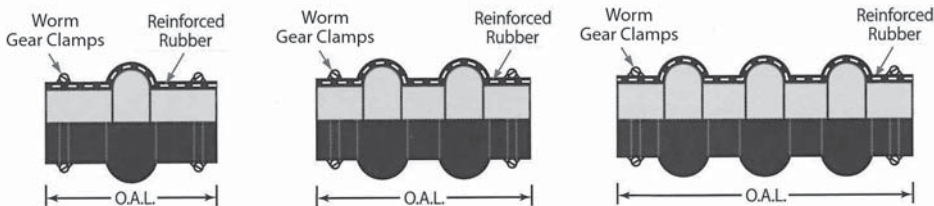

NPS	Sleeve			Face-To-Face			Single Arch Non-Concurrent Design Movement					Spring Rate				Thrust Factor Effective Area	Working Pressure 4 to 1 Safety Factor
	B ID	A Length	C Cuff	1 Arch	2 Arches	3 Arches	Axial Comp.	Axial Ext.	Lateral Def.	Angular	Torsional	Axial Comp.	Axial Ext.	Lateral	Angular		
inch	inch	inch	inch	inch	inch	inch	inch	inch	inch	deg	deg	lb/in	lb/in	lb/in	lb*in/deg	sq.in.	psi
1	1.315	6	2	6	12	16	1.75	0.875	0.75	30.0	0.5	30	39	51	59	9.62	50
1.5	1.900	6	2	6	12	16	1.75	0.875	0.75	24.0	0.5	45	59	77	88	12.57	50
2	2.375	6	2	6	12	16	1.75	0.875	0.75	22.0	0.5	55	71	92	106	15.9	50
2.5	2.875	6	2	6	12	16	1.75	0.875	0.75	20.0	0.5	68	88	115	133	19.63	50
3	3.500	6	2	6	12	16	1.75	0.875	0.75	19.0	0.5	87	113	146	169	23.76	50
4	4.500	6	2	6	12	16	1.75	0.75	0.75	12.0	0.5	108	141	184	212	33.2	25
6	6.625	6	2	6	12	16	1.75	0.75	1.00	10.0	0.5	155	201	261	301	56.7	25
8	8.625	6	2	6	12	18	1.75	0.75	1.00	9.0	0.5	179	233	303	350	86.6	25
10	10.750	6	2	8	16	20	1.75	0.75	1.00	8.0	0.5	205	266	346	399	132.7	25
12	12.750	6	2	8	16	20	1.75	0.75	1.00	7.0	0.5	230	299	389	449	189	25
14	14.000	10	3	8	16	20	1.75	0.75	1.00	6.0	0.5	257	334	435	501	241	25
16	16.000	10	3	8	16	20	1.75	0.75	1.00	6.0	0.5	284	369	480	554	299	25
18	18.000	10	3	8	16	20	1.75	0.75	1.00	5.0	0.5	312	405	527	608	363	25
20	20.000	10	3	8	16	20	1.75	0.75	1.00	5.0	0.5	337	438	569	656	434	25
24	24.000	10	3	10	16	22	1.75	1.00	1.00	5.0	0.5	383	498	647	746	616	25
36	36.000	12	4	10	18	22	2.25	1.00	1.00	3.0	0.5	541	703	914	1,055	1288	15
48	48.000	12	4	12	18	22	2.25	1.00	1.00	3.0	0.5	639	831	1,081	1,247	2165	10
60	48.000	12	4	12	18	22	2.25	1.25	1.00	2.0	0.5	824	1,071	1,392	1,606	3267	5
72	72.000	12	4	12	18	22	2.25	1.25	1.00	2.0	0.5	978	1,272	1,654	1,908	4596	5

Ordering information see page 82

Special notes on movement capability: 1) Filled arch construction reduces above movements by 50%. 2) To calculate movement of multiple arch type for compression, extension and lateral movements, take movement shown in the above table and multiply by the number of arches. 3) The degree of angular movement is based on the maximum extension shown. 4) Movement capability shown is non-concurrent percentage used in one movement position must be deducted from the other movement position so that sum of movements don't exceed 100%. 5) Movements shown are based on proper installation practices. See Thorburn installation maintenance guide for details.

Special notes on force Pounds / Spring Rates: 1) Forces required to move Thorburn Mighty-Spool Model 30DB are based on zero pressure conditions and room temperature in the pipeline. 2) These forces should be considered only as approximates, compensation must be made for more accurate forces based on materials of construction and actual service conditions. 3) Filled arch spring rates are approximately 4 times that of a single open arch. 4) Multi-arch spring rates are equal to single arch divided by number of arches.



15RA Series Technical Data

Thorburn's 15RA are ultra-flexible rubber expansion joints designed for low pressure, where misalignment is problematic e.g. settlement of large above ground storage tanks. Compressible ground and storage weight results in tank settling resulting in problems when rigid piping is connected to the storage tank. Relative changes in elevation occur over time between the storage tank and the connecting piping causing sizable shear and bending loads on the pipe storage tank nozzles. **Available in full vacuum style. Please use Part# 15RAV**

NPS	Face-To-Face			Single Arch Non-Concurrent Design Movements					Spring Rate				Thrust Factor Effective Area	Working Pressure 4 to 1 Safety Factor
	1 Arch	2 Arches	3 Arches	Axial Compression	Axial Extension	Lateral Deflection	Angular	Torsional	Axial Compression	Axial Extension	Lateral	Angular		
inch	inch	inch	inch	inch	inch	inch	deg	deg	lb/in	lb/in	lb/in	lb*in/deg	sq.in.	psi
1	6	12	16	1.75	0.75	0.75	30.0	2.0	39	51	59	0.03	14.25	50
1.25	6	12	16	1.75	0.75	0.75	28.0	2.0	49	64	74	0.05	15.98	50
1.5	6	12	16	1.75	0.75	0.75	26.0	2.0	59	77	88	0.08	17.80	50
2	6	12	16	1.75	0.75	0.75	24.0	2.0	71	92	106	0.2	21.73	50
2.5	6	12	16	1.75	0.75	0.75	22.0	2.0	88	115	133	0.3	26.06	50
3	6	12	16	1.75	0.75	0.75	20.0	2.0	113	146	169	0.4	30.78	50
4	6	12	16	1.75	0.75	0.75	19.0	2.0	141	184	212	0.5	41.4	25
5	6	12	16	1.75	0.75	0.75	15.0	2.0	171	222	256	0.9	53.6	25
6	6	12	16	1.75	0.75	1.00	12.0	2.0	201	261	301	2	67.3	25
8	6	12	18	1.75	0.75	1.00	10.0	2.0	233	303	350	3	103.9	25
10	8	16	20	1.75	0.75	1.00	9.0	2.0	266	346	399	6	143.1	25
12	8	16	20	1.75	0.75	1.00	8.0	2.0	299	389	449	7	189	25
14	8	16	20	1.75	0.75	1.00	7.0	2.0	334	435	501	10	284	25
16	8	16	20	1.75	0.75	1.00	6.0	2.0	369	480	554	13	346	25
18	8	16	20	1.75	0.75	1.00	6.0	2.0	405	527	608	18	415	25
20	8	16	20	1.75	0.75	1.00	5.0	2.0	438	569	656	25	491	25
22	10	16	22	1.75	0.75	1.00	5.0	2.0	469	610	704	34	573	25
24	10	16	22	1.75	1.00	1.00	5.0	2.0	498	647	746	46	661	25
26	10	16	22	1.75	1.00	1.00	4.0	2.0	529	688	794	49	779	25
28	10	16	22	1.75	1.00	1.00	4.0	2.0	563	732	844	64	881	25
30	10	16	22	1.75	1.00	1.00	4.0	2.0	597	776	896	73	990	25
32	10	16	22	1.75	1.00	1.00	4.0	2.0	628	817	942	93	1,104	25
34	10	16	22	1.75	1.00	1.00	3.0	2.0	667	867	1,001	108	1,225	25
36	10	18	22	2.25	1.00	1.00	3.0	2.0	703	914	1,055	141	1,353	25
40	10	18	22	2.25	1.00	1.00	3.0	2.0	739	961	1,109	174	1,626	15
42	12	18	22	2.25	1.00	1.00	3.0	2.0	785	1,021	1,178	194	1,792	15
48	12	18	22	2.25	1.00	1.00	3.0	2.0	831	1,081	1,247	304	2,270	15
50	12	18	22	2.25	1.00	1.00	3.0	2.0	883	1,148	1,325	328	2,442	15
54	12	18	22	2.25	1.25	1.00	3.0	2.0	937	1,219	1,406	357	2,805	15
56	12	18	22	2.25	1.25	1.00	2.0	2.0	998	1,297	1,497	385	2,996	15
60	12	18	22	2.25	1.25	1.00	2.0	2.0	1,071	1,392	1,606	590	3,396	10
66	12	18	22	2.25	1.25	1.00	2.0	2.0	1,166	1,516	1,749	667	4,044	10
72	12	18	22	2.25	1.25	1.00	2.0	2.0	1,272	1,654	1,908	947	4,749	10
78	12	18	22	2.25	1.25	1.00	1.0	2.0	1,383	1,797	2,074	1,029	5,510	10
84	12	18	22	2.25	1.25	1.00	1.0	2.0	1,542	2,005	2,314	1,111	6,362	5
96	12	18	22	2.25	1.25	1.00	1.0	2.0	1,696	2,205	2,544	1,275	8,171	5
108	12	18	22	2.25	1.25	1.00	1.0	2.0	1,908	2,480	2,862	1,439	10,207	5
120	12	18	22	2.25	1.25	1.00	1.0	2.0	2,120	2,756	3,180	1,649	12,469	5
132	12	18	22	2.25	1.25	1.00	1.0	2.0	2,332	3,032	3,498	1,814	14,957	5
144	12	18	22	2.25	1.25	1.00	1.0	2.0	2,544	3,307	3,816	1,904	17,671	5

Ordering information see page 82

Special notes on movement capability: 1) Filled arch construction reduces above movements by 50%. 2) To calculate movement of multiple arch type for compression, extension and lateral movements, take movement shown in the above table and multiply by the number of arches. 3) The degree of angular movement is based on the maximum extension shown. 4) Movement capability shown is non-concurrent percentage used in one movement position and must be deducted from the other movement position so that sum of movements don't exceed 100%. 5) Movements shown are based on proper installation practices. See Thorburn installation maintenance guide for details.

Special notes on force Pounds / Spring Rates: 1) Forces required to move Thorburn Mighty-Spool Model 15RA are based on zero pressure conditions and room temperature in the pipeline. 2) These forces should be considered only as approximates, compensation must be made for more accurate forces based on materials of construction and actual service conditions. 3) Filled arch spring rates are approximately 4 times that of a single open arch. 4) Multi-arch spring rates are equal to single arch divided by number of arches.

Thorburn 15RRA Rectangular & Square Arch Type Expansion Joints



Thorburn's 15RRA rectangular heavy duty single molded arch type expansion joint

Thorburn's 15RRA is a rectangular or square heavy duty, molded arch, integral flanged expansion joint. The arch has rounded corners, specifically designed to prevent corner folds. It is typically manufactured in a single arch profile and also available in double and triple arch design. The arch profile continues seamlessly through the corner and straight sections, covering the entire circumference of the expansion joint.

Thorburn's 15RRA expansion joint system is used for applications where higher pressures with large movements are required. The flexible element is constructed with 4 or 6 plies of high tensile calendered fabric which provides added strength for pressure containment and prevents flutter.

Design Specifications

Movements: Lateral offset figures are based on the assumption that all lateral movement occurs prior to compression movements. In practice, movements occur simultaneously thus the allowable lateral offset would increase. Greater extension and/or lateral offset is gained through design of longer "built-in" flanges. Anchors should be located so rated movements are not exceeded.

Reinforcement: Calendered aramid, polyester and fiberglass

Minimum Thickness: 13mm

Elastomers: Available in all elastomers

For ordering information, see Page 82 for details

Backing Rings: "L" Shaped for added sealing force. Available in carbon steel SA516-70, SA36 and stainless steel SA240 type 304, 316/316L

Pressure (depending on size): 20 Kpa to 70 Kpa (3 psi to 10 psi)

Vacuum (depending on size): All applications less than -80mm of H2O (-3 psi) contact Thorburn Engineering with application requirements. In vacuum applications a "set-back" design should be used. When full vacuum is required, please use Thorburn's Dog-Bone expansion joint Model DBE-CR.

Thorburn 15R-HDI & 15R-HDE "U" Type Flanged Expansion Joints

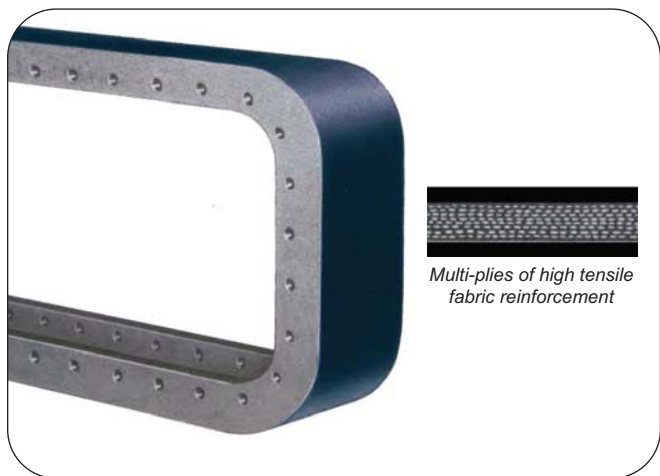

Thorburn's rubber "U-type" expansion joint with internal flange design

Multi-ply of high tensile fabric reinforcement

Thorburn's Rubber "U-Type" Heavy Duty Expansion Joints are constructed with multiple plies of calendered fabric and are available in a variety of elastomers. The integral rubber flange provides a leak tight seal between the turbine and the condenser. Thorburn Model 15R-HDI & 15R-HDE are a superior alternate to the traditional dogbone expansion joint (see page 22). Thorburn's "U-Type" expansion joints neutralizes stress between the turbine and the condenser, provides full vacuum service and absorbs movement caused by thermal and mechanical deflection.

Site Splicing

Thorburn offers site splicing in cases where an endless membrane cannot be installed due to internal piping interference. Thorburn employs hot molded splicing constructed with the original materials.



Thorburn's rubber "U-type" expansion joint with external flange design

For ordering information, see Page 82 for details

Thorburn's Dog-Bone Expansion Joint Model DBE-CR



Thorburn's Dog-Bone expansion joint installed in a power plant in upstate New York, USA

Thorburn's Dog Bone Expansion Joint model DBE-CR maintains a flexible connection and seal between the low pressure turbine and the exhaust hood. The flexible element is constructed with multiple plies of calendered fabric which is enveloped in chloroprene rubber. It can be manufactured in our factory with an endless splice (like a rubber band) or spliced at site to a specified peripheral dimension. Thorburn's Dog Bone cross-section has (2) 35mm (1 3/8") diameter bulbs to make a tight seal when clamped in place. A rope core is embedded in each bulb to promote sealing integrity and a firm base for the clamping hardware.



Thorburn's Dog-Bone Assembly

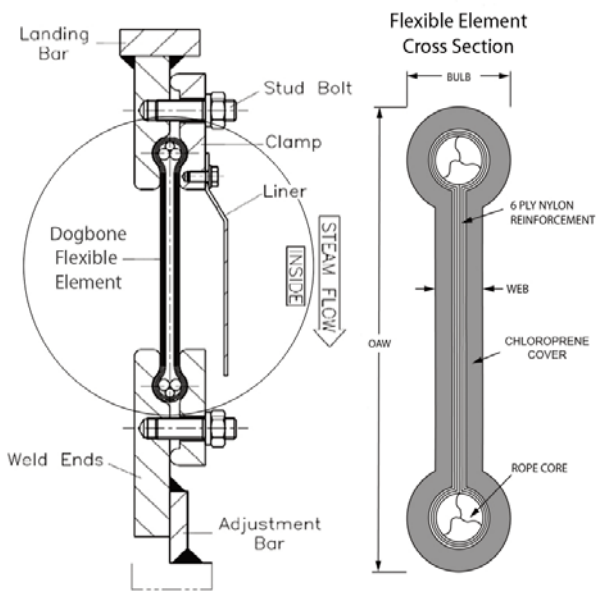

Standard Thorburn Dog-Bone Sizes

Part Number	Overall Width	Body/Web Thickness	Bulb Diameter
DBE-CR-150-08	240mm (9 3/8")	12.7 mm (1/2")	35mm (1 3/8")
DBE-CR-156-08	250mm (9 3/4")	12.7 mm (1/2")	35mm (1 3/8")
DBE-CR-160-10	254mm (10")	16mm (5/8")	35mm (1 3/8")

Note: Other Thicknesses and widths available upon request



Thorburn's Dog-Bone Expansion Joint Model DBE-CR with flexible element, clamping bars and bolt-in liner

Clamping

Thorburn's Dog-Bone belt has self-sealing rubber bulbs that are sandwiched between machined connecting clamps at each end. Clamp materials are typically made of SA 516 GR-70. (Other materials such as SS304 & SS316 are also available)

Inner Liner

Secures a smooth flow that protects the Dog-Bone belt from flow induced flutter/vibration and erosion.

Connecting Ends

Can be supplied with landing bars or weld ends for welding to the duct or with flanges.

Design Specifications (240mm Width)

Axial Compression: 25mm (1")

Axial Extension: 3mm (1/8")

Lateral Deflection: 12mm (1/2")

Pressure: Full Vacuum to 1 bar (15psi)

Continuous Operating Temperature: 110°C (230°F)

Intermittent Temperature: 138°C (280°F) Max 36 Hours

Construction

Elastomeric Envelope: Chloroprene

Reinforcement: 6 Plies Calendered high tensile nylon fabric

Bulb: 35mm diameter with a rope core

For ordering information, please contact Thorburn for details

Control Rod & Restraint Assemblies



Internal Lug & Retaining Ring System

External Lug & Retaining Ring System

Thorburn's style "CR" control rod assembly system consists of two or more control rods extending from the mating flanges of the expansion joint, minimizing possible damage to the expansion joint caused by excessive movement of the pipeline. Thorburn's control rod assembly systems are set at the maximum allowable expansion of the joint and absorb the static pressure thrust developed at the expansion joint. Over compression of the expansion joints can be controlled by installing rubber pipe sleeves over the control rods or internal nuts. The length of the pipe sleeve is such that the expansion joint cannot be compressed beyond its maximum allowable compression capabilities. When the control rod system is used as a movement limiting rod, washers are not necessary and is used to restrain pressure thrust. *(The term "Control Unit" is synonymous with the term "Tie Rod" as defined by the Expansion Joint Manufacturer's Association (EJMA))*

Thorburn's three nut control rod unit standard

Thorburn utilizes a second nut at one end of its control rod while the other end of the rod has its nut permanently tack welded in place.

This design...

- Permits safe, easy installation and disassembly (for scheduled maintenance or repair) of the control rod unit
- Allows the control rod assembly unit to be adjusted after the joint has had time to settle
- Makes it impossible to vibrate loose
- Resists the axial extension loads of the piping system.

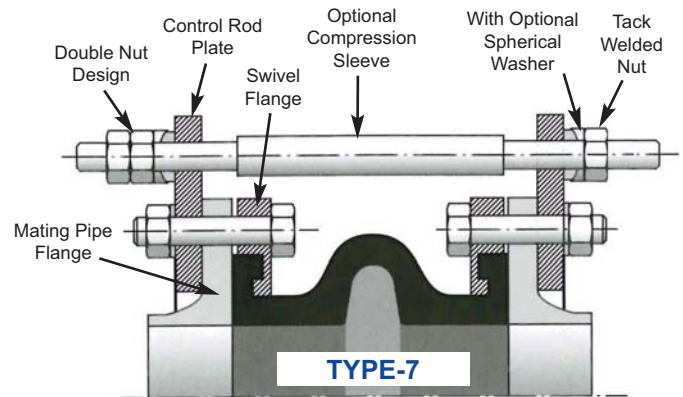

Thorburn Style 101 spherical arch complete with control rod assembly
 • Axial compression & lateral movement • External lug plates
 • Control rods, nuts & spherical washers • Compression limiter sleeve

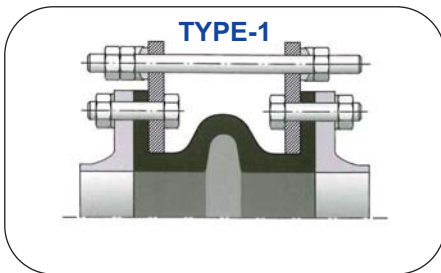

• Axial compression & lateral movement
 • integral retaining ring & lug plate • Control rods with spherical washers

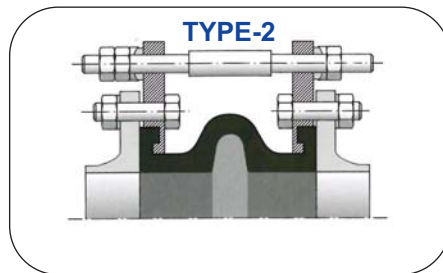

• Axial compression & lateral movement • integral backing flange and control rods with spherical washers • Compression limiter sleeve

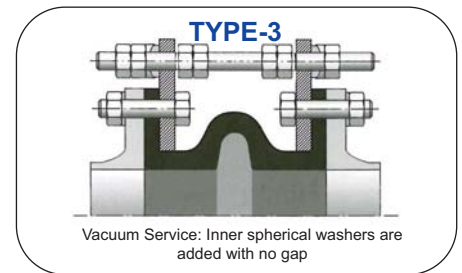

Vacuum Service: Inner spherical washers are added with no gap
 • Lateral movement • integral retaining ring & lug plate • Control rods with spherical washers & internal compression limiting nuts

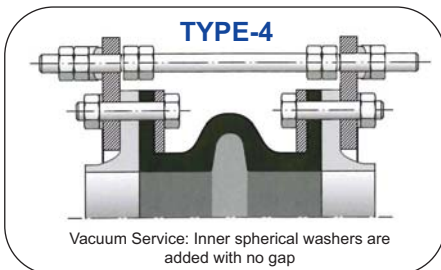

Vacuum Service: Inner spherical washers are added with no gap

• Lateral movement • Retaining rings & external lug plate • Control rods with spherical washers & internal compression limiting nuts

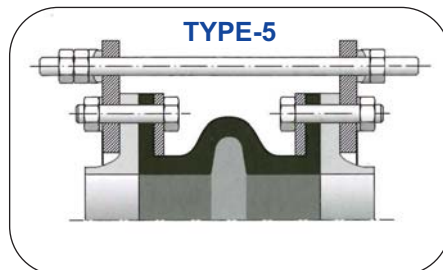

• Axial & lateral movement • Retaining rings & external lug plate • Control rods with spherical washers

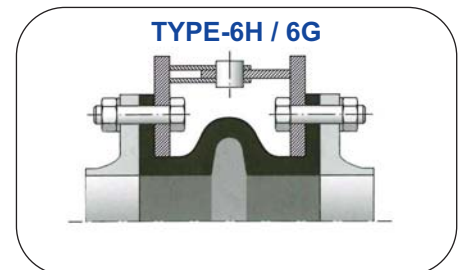

• Angular movement in one plane (6H) or multi-plane (6G) • Integral lug plates & retaining ring with hinged arrangement

Control Unit Dimension & Ratings

Nominal Pipe Size EJ ID	Control Unit				Maximum Surge or Test Pressure of the Systems				
	Plate Thickness	Rod Diameter	Standard Control Unit Assembly of:		Number of Recommended Control Rods				
in	in	in	Rods	Plates	2	3	4	6	8
1/2	3/8	1/2	2	4	1323	•	•	•	•
3/4	3/8	1/2	2	4	1106	•	•	•	•
1	3/8	1/2	2	4	949	•	•	•	•
1 1/4	3/8	1/2	2	4	830	•	•	•	•
1 1/2	3/8	1/2	2	4	510	•	•	•	•
2	3/8	5/8	2	4	661	•	•	•	•
2 1/2	3/8	5/8	2	4	529	•	•	•	•
3	3/8	5/8	2	4	441	•	•	•	•
3 1/2	3/8	5/8	2	4	365	547	729	•	•
4	3/8	5/8	2	4	311	467	622	•	•
5	3/8	5/8	2	4	235	353	470	•	•
6	1/2	5/8	2	4	186	278	371	•	•
8	1/2	3/4	2	4	163	244	326	•	•
10	3/4	7/8	2	4	163	244	325	488	•
12	3/4	1	2	4	160	240	320	481	•
14	3/4	1	2	4	112	167	223	335	•
16	3/4	1 1/8	2	4	113	170	227	340	453
18	3/4	1 1/8	2	4	94	141	187	281	375
20	3/4	1 1/8	2	4	79	118	158	236	315
22	1	1 1/4	2	4	85	128	171	256	342
24	1	1 1/4	2	4	74	110	147	321	294
26	1	1 1/4	2	4	62	93	124	186	248
28	1 1/4	1 3/8	2	4	65	98	130	195	261
30	1 1/4	1 1/2	2	4	70	105	141	211	281
32	1 1/4	1 1/2	2	4	63	94	125	188	251
34	1 1/2	1 5/8	2	4	72	107	143	215	286
36	1 1/2	1 3/4	2	4	69	103	138	207	276
38	1 1/2	1 3/4	2	4	63	94	125	188	251
40	1 1/2	1 1/2	3	6	42	63	85	127	169
42	1 1/2	1 5/8	3	6	48	72	96	144	192
44	1 1/2	1 5/8	3	6	44	66	88	133	177
46	1 1/2	1 5/8	3	6	41	61	82	122	163
48	1 1/2	1 5/8	3	6	40	60	81	121	161
50	1 1/2	1 5/8	3	6	37	56	75	112	150
52	1 1/2	1 5/8	3	6	35	53	70	105	140
54	1 1/2	2	3	6	43	64	86	128	171
56	1 1/2	2	3	6	40	60	80	120	160
58	1 1/2	2	3	6	38	56	75	113	150
60	1 3/4	2	3	6	35	53	71	106	141
62	1 3/4	2	4	8	33	50	66	100	133
66	1 7/8	2	4	8	30	44	59	89	119
72	1 7/8	2	4	8	25	38	50	75	101
78	2	2 1/4	4	8	28	42	56	84	112
84	2 1/4	2 1/4	4	8	24	37	49	73	98
90	2 1/2	2 1/2	4	8	26	40	53	79	106
96	2 1/2	2 1/2	4	8	29	43	58	86	115
102	2 1/2	2 3/4	4	8	25	33	51	76	102
108	2 1/2	2 3/4	4	8	23	34	46	75	92
120	2 1/2	2 3/4	4	8	18	28	37	56	75
132	2 1/2	2 3/4	4	8	15	23	31	46	62
144	2 1/2	2 3/4	6	12	13	19	26	39	52

How to Order

(Joint)(Size (in))X(FF (in)) -(Type)(CR)(Quantity) - (Material) - (Option)

42HPW-6X12-5CR2-S4-SW

Description:

Two (2) Control rod assemblies made of 304SS for a 6" ID expansion joint complete with a spherical washer system.

Ordering Codes:

CR = Control Rod

Types = 1, 2, 3, 4, 5, 6H, 6G, 7 (see page 23)

Material Codes:

Standard carbon steel = Leave Blank

S4 = 304SS

S6 = 316SS

X = Other specify

Option:

SW = Spherical Washer (Case hardened carbon steel)

Notes:

1. Recommended plate thickness and rod diameter based on a yield strength of 36,000 PSI with a maximum allowable stress of 23,400 PSI (65% of yield). Rod and plate loads based on thrust, calculated using typical Thorburn arch inside diameter dimensions. (Typical control rod assembly materials: SA193 Gr B7, Nut: SA194 Gr 2H, Plate: SA36 Spherical washers: Case hardened steel)

2. A "Standard Control Unit Assembly" is generally furnished when ordered, if specifications and/or order does not call for a specific number of control rods. The CR plate & CR are the same material unless specified separately.

3. The pressures listed do not relate to the actual design pressure of the expansion joint product, but are the maximum pressure for a specific control rod number/dimension.

Thorburn's Spherical Washer System



Thorburn's spherical concave & convex washer system

Thorburn's unique spherical washer system provides a smooth non-binding equal force on the control rod when the expansion joint deflects laterally, angularly and torsionally.

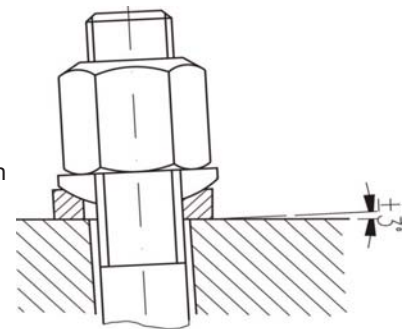

Guiding & Anchoring Practices With Rubber Expansion Joint Systems

It is absolutely necessary that rigid metal pipe on both ends of the rubber expansion joint be properly anchored to eliminate the danger of excessive elongation. Anchors should be provided at:

- A change in pipe size
- A branching of pipe
- A change of pipe direction
- The end of a pipe run

Warning: An expansion joint should never be used to support the piping.

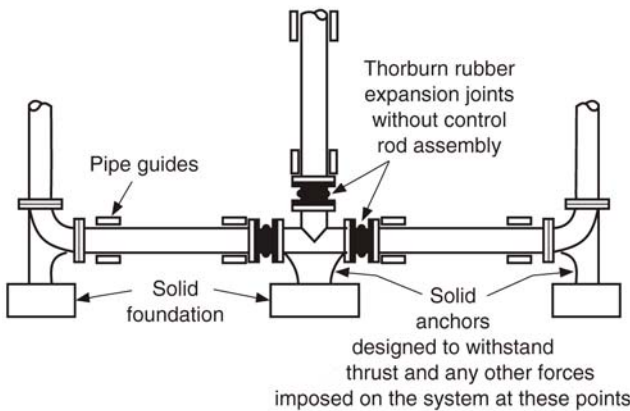

Fig 1: Typical piping layout utilizing Thorburn expansion joints and the proper use of anchors in branch locations

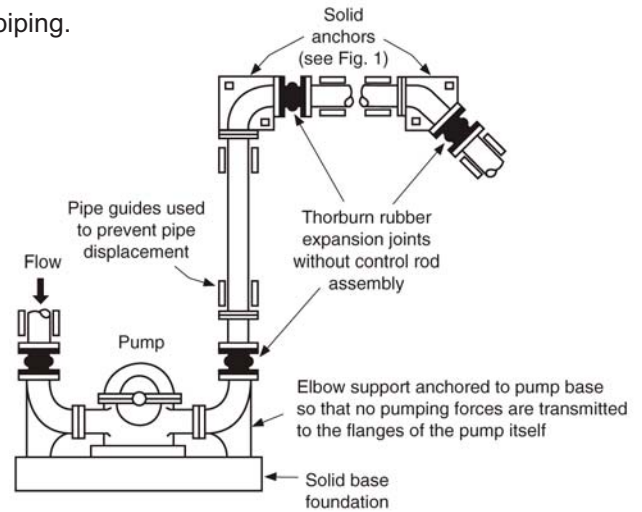

Fig 2: Typical piping layout utilizing Thorburn rubber expansion joints when equipment and piping are properly anchored

Employing Thorburn’s control rod assembly system to protect your piping system

Thorburn’s control rod assembly in Fig. 3 permits the expansion of the pipeline in both the vertical and horizontal directions between the pump and the anchor at the 45° bend. The permitted movement allowed by the control rod assembly is restricted to the design limitations of Thorburn’s expansion joint.

Warning: When anchoring is not present in a piping run, it is mandatory that a Thorburn control rod assembly be employed with our expansion joints. Without the use of Thorburn’s control rod assembly in Fig. 3, the pipeline between the pump and the anchor at the 45° bend would be severely displaced because the piping systems’ pressure thrust forces would cause Thorburn’s rubber expansion joints to extend until they rupture.

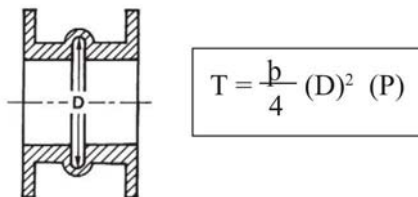

Fig 4: Thrust formula and location of expansion joint arch I.D.

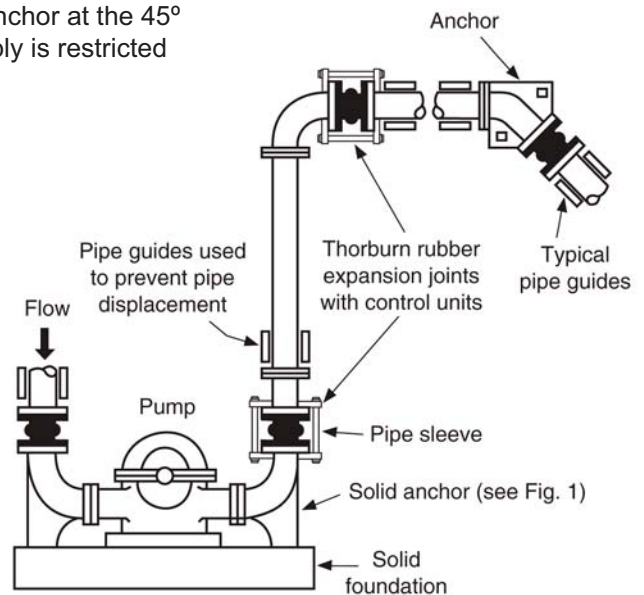

Fig 3: Typical piping layout showing the use of control units with the expansion joints when proper system anchoring is limited

Mating Flange Thickness

Nominal Pipe Size	ANSI B16.1 Cl.25	ANSI B16.1 Cl.125	ANSI B16.24 150 lb Cl. 25	ANSI B16.5 Cl.150	AWWA C207 Table 1 Cl.B	AWWA C207 Table 1 Cl. D	AWWA C207 Table 2 Cl. A&B	AWWA C207 Table 3 Cl. E	MSS SP-44 Cl. 150
in	in	in	in	in	in	in	in	in	in
1/2	•	•	5/16	7/16	•	•	•	7/16	•
3/4	•	•	11/32	1/2	•	•	•	1/2	•
1	•	7/16	3/8	9/16	•	•	•	9/16	•
1 1/4	•	1/2	13/32	5/8	•	•	•	5/8	•
1 1/2	•	9/16	7/16	11/16	•	•	•	11/16	•
2	•	5/8	1/2	3/4	•	•	•	3/4	•
2 1/2	•	11/16	9/16	7/8	•	•	•	7/8	•
3	•	3/4	5/8	15/16	•	•	•	15/16	•
3 1/2	•	13/16	11/16	15/16	•	•	•	15/16	•
4	3/4	15/16	11/16	15/16	•	•	•	15/16	•
5	3/4	15/16	3/4	15/16	5/8	5/8	1/2	15/16	•
6	3/4	1	13/16	1	11/16	11/16	9/16	1	•
8	3/4	1 1/8	15/16	1 1/8	11/16	11/16	9/16	1 1/8	•
10	7/8	1 3/16	1	1 3/16	11/16	11/16	11/16	1 3/16	•
12	1	1 1/4	1 1/16	1 1/4	11/16	13/16	11/16	1 1/4	1 1/4
14	1 1/8	1 3/8	•	1 3/8	11/16	15/16	3/4	1 3/8	1 3/8
16	1 1/8	1 7/16	•	1 7/16	11/16	1	3/4	1 7/16	1 7/16
18	1 1/4	1 9/16	•	1 9/16	11/16	1 1/16	3/4	1 9/16	1 9/16
20	1 1/4	1 11/16	•	1 11/16	11/16	1 1/8	3/4	1 11/16	1 11/16
22	•	•	•	•	3/4	1 3/16	1	•	1 13/16
24	1 3/8	1 7/8	•	1 7/8	3/4	1 1/4	1	1 7/8	1 7/8
26	•	•	•	•	13/16	1 5/16	1	2	2 11/16
28	•	•	•	•	7/8	1 5/16	1	2 1/16	2 13/16
30	1 1/2	2 1/8	•	•	7/8	1 3/8	1	2 1/8	2 15/16
32	•	•	•	•	15/16	1 1/2	1 1/8	2 1/4	3 3/16
34	•	•	•	•	15/16	1 1/2	1 1/8	2 5/16	3 1/4
36	1 5/8	2 3/8	•	•	1	1 5/8	1 1/8	2 3/8	3 9/16
38	•	•	•	•	1	1 5/8	1 1/8	2 3/8	3 7/16
40	•	•	•	•	1	1 5/8	1 1/8	2 1/2	3 9/16
42	1 3/4	2 5/8	•	•	1 1/8	1 3/4	1 1/4	2 5/8	3 13/16
44	•	•	•	•	1 1/8	1 3/4	1 1/4	2 5/8	4
46	•	•	•	•	1 1/8	1 3/4	1 1/4	2 11/16	4 1/16
48	2	2 3/4	•	•	1 1/4	1 3/4	1 3/8	2 3/4	4 1/4
50	•	•	•	•	1 1/4	2	1 3/8	2 3/4	4 3/8
52	•	•	•	•	1 1/4	2	1 3/8	2 7/8	4 9/16
54	2 1/4	3	•	•	1 3/8	2 1/8	1 3/8	3	4 3/4
56	•	•	•	•	•	•	•	•	4 7/8
58	•	•	•	•	•	•	•	•	5 1/16
60	2 1/4	3 1/8	•	•	1 1/2	2 1/4	1 1/2	3 1/8	5 3/16
62**	•	•	•	•	•	•	•	•	•
66	•	•	•	•	1 5/8	2 1/2	1 1/2	3 3/8	•
72	2 1/2	3 1/2	•	•	1 3/4	2 5/8	1 1/2	3 1/2	•
78	•	•	•	•	2	2 3/4	1 3/4	3 7/8	•
84	2 3/4	3 7/8	•	•	2	2 3/4	1 3/4	3 7/8	•
90**	•	•	•	•	•	•	•	•	•
96	3	4 1/4	•	•	2 1/4	3	2	4 1/4	•
102	•	•	•	•	2 1/2	3 1/4	2 1/4	4 5/8	•
108	•	•	•	•	2 1/2	3 1/4	2 1/4	4 5/8	•
120	•	•	•	•	2 3/4	3 1/2	2 1/2	5	•
132	•	•	•	•	3	3 3/4	2 3/4	5 3/8	•
144	•	•	•	•	3 1/4	4	3	5 3/4	•

Thorburn's "RR" Split Retaining Rings

Thorburn split retaining rings are installed directly against the back of the expansion joint flanges. They are used to equally distribute the bolting pressure to provide a unified compression force on the back of the expansion joint flange. This ensures a leak tight seal between the expansion joint rubber flange and the mating flange. A bevel is added to the retaining ring so that it will not cut the expansion joint body during bolt-up. The typical retaining ring thickness is 10mm (3/8") but other thicknesses are used depending upon pressure and application conditions.



Thorburn's "RI" Integral Retaining Rings

Thorburn's proprietary "IR" Integral retaining ring is an advancement of our standard retaining ring because it is made in one circular piece without a split. This integral ring is vulcanized on the back of the rubber flange and further improves sealing when bolted to the mating flange.



Retaining Ring Materials and Drilling Patterns

Thorburn's "L" shaped and split retaining rings are typically made of carbon steel (SA36 or SA516 grade 70 material), zinc or galvanized plated for corrosion resistance. Other materials such as SA240 Type 304SS, 316SS, Inconel SB443 Type 625, Hasteloy SB575 Type C276 are also available. The drilling pattern is typically ANSI B16.5 Class 150, ANSI B16.5 Class 300, AWWA C207-78 Table 1 & 2 Class B or Class D, ISO 2084-1974 Table NP-10, B.S. 10 Table E, J.I.S. B2212 and other standard or custom drilling patterns are available.



How to Order

42HPW-42-RRL-S4

Description:

42HP EJ Size 42 in with "L" shaped retaining rings, 304SS material

Ordering Codes:

RR = Retaining Ring
RI = Integral Retaining Ring
RL = "L" Shaped Retaining Ring

Material Codes:

Standard carbon steel = Blank
S4 = 304SS, **S6** = 316SS
M = Monel, **I** = Inconel 625
D5 = Duplex 2205
D7 = Super Duplex 2507
Y = Other specify

Note: Standard thickness 10mm (3/8"), other thicknesses use suffix "X" and specify.

Mighty Spool Rubber Hinged & Gimbal Expansion Joints

For Models 42HPW, 62HP, 42HPXX, 15RA



Thorburn's 42HP-6GU Universal Rubber Gimbal Expansion Joint

42HP-6G Gimbal Expansion Joint

Thorburn's Rubber Gimbal Expansion Joints are typically used in sets of two or three, to absorb pipe movement in two or more directions in a multiple plane piping system. The gimbal structure is custom designed to absorb the full pressure thrust forces and all dead weight loads, wind loads and shear loads.

Advantages

- Angular movement in more than one plane
- Eliminates pressure thrust forces
- No main anchor required
- Low forces on piping system
- Prevents torsion loads on rubber bellows
- Filled arch design prevents media sediment buildup



Gimbal Expansion Joint

Thorburn's 42HP-6GU Universal Rubber Gimbal Expansion Joint demonstrating the absorption of angular deflection in more than one plane

42HP-6H Hinged Expansion Joint

Thorburn's Rubber Hinge Expansion Joints are typically used in sets of two or three, to absorb pipe movement in one or more directions in a single plane piping system. Each individual joint in the system is restricted to pure angular rotation by its hinges. The hinge structure is custom designed to absorb the full pressure thrust forces and dead weight loads.

Advantages

- Angular motion in one plane only
- Eliminates pressure thrust forces
- No main anchors required
- Low forces on piping system
- Prevents torsion loads on rubber bellows
- Filled arch design prevents media sediment buildup



Hinge Expansion Joint

Thorburn's 42HP-6HU Universal Rubber Hinged Expansion Joint demonstrating the absorption of angular deflection in one plane

Please see Page 26 for restraint types and Page 82 for ordering information

42HP-PB In-line Rubber Pressure Balanced Expansion Joints

For Models 42HPW, 62HP, 42HP & 42HPXX



Thorburn's 42HPX-PB 1830mm (72") In-line Pressure Balanced Expansion Joint installed at a power plant in Saudi Arabia

Operating Principal of Thorburn's 42HP-PB To Neutralize Pressure Thrust Forces

Thorburn's 42HP-PB has a balancing bellows with an effective area twice as large as the line bellows. The inter-linking arrangement of the tie rods transfers and balances the pressure thrust loads. As the line bellows are compressed, the balancing bellows are extended an equal amount without volume change. Eliminating volume change ensures that the thermal growth loads are absorbed within the expansion joint and not transferred to the adjacent equipment. Therefore, the only loads acting on the piping system are the sum of the forces needed to compress or extend the expansion joint.

Advantages

Neutralizes Pressure Thrust:

Pressure balanced control rod system is custom designed to absorb the full pressure thrust forces, dead weight loads and eliminates the requirement for main anchors

Replaces Pipe Loops:

Reduces piping energy by eliminating pressure losses generated by the loop elbow

Extremely Compact:

Greater flexibility in piping layout

Filled arches:

Smooth unrestricted flow prevents media sediment buildup.

Freedom from Corrosion and Embrittlement:

Impervious to corrosive media degradation, flex fatigue and shock

Super Abrasive and Erosion Resistance:

Available with smooth filled arches, abrasive resistant lining protects against sea water salt, slurry and other abrasive media

Wetted Metal Components Can Be Cladded or Rubber Lined:

Enhances corrosion & abrasive resistance at a fraction of the cost.

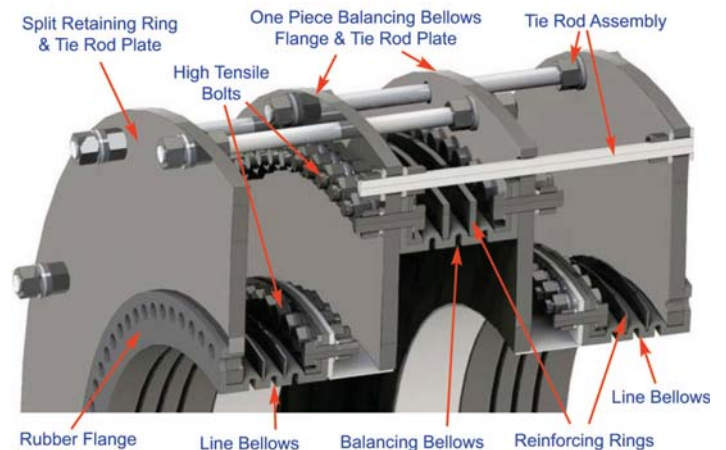

Design

- ASME B31.1, B31.3 Pressure Piping Certification
- FSA Technical Handbook 8th Edition
- Sizes 12.7mm (1/2") to 4000mm (276") ID
- Pressures full vacuum to 20 bar
- Available with CRN

For ordering information, please contact Thorburn for details



Common Flange Dimensions & Drilling Chart

Nominal Pipe Size Expansion Joint ID	25 / 125 / 150 LB. Drilling								250 / 300 LB. Drilling			
	Specifications								Specifications			
	ANSI B16.1 - 1975 Class 25 (B) ANSI B16.1 - 1975 Class 125 (A) ANSI B16.24 - 1971 (A) AWWA C207-07 Tbl 2 & 3 Class D (D) ANSI B16.5 Class 125/150 (C)				AWWA C207-07, Tbl 2 & 3, Class D. Tbl 4, Class E (C) MSS SP-44 1975 Class 150 (A) SS SP-51 1965 MSS 150# (A) 1914 Amor Std for Ranges (E)				ANSI B16.1 - 1975 Class 250 ANSI B16.24 - 1971 300 lb ANSI B16.5 - 1973 Class 300 MSS SP-44 1975 Class 300			
	Common Size			Bolt Hole Size					OD	BC	No. Of Holes	Hole Diameter
	OD	BC	No. Of Holes	Drilling Column								
			A	B	C	D	E					
1/2	3 1/2	2 3/8	4	5/8	•	5/8	•	9/16	3 3/4	2 5/8	4	5/8
3/4	3 7/8	2 3/4	4	5/8	•	5/8	•	•	4 5/8	3 1/4	4	3/4
1	4 1/4	3 1/8	4	5/8	•	5/8	•	•	4 7/8	3 1/2	4	3/4
1 1/4	4 5/8	3 1/2	4	5/8	•	5/8	•	•	5 1/4	3 7/8	4	3/4
1 1/2	5	3 7/8	4	5/8	•	5/8	•	5/8	6 1/8	4 1/2	4	7/8
2	6	4 3/4	4	3/4	•	3/4	•	3/4	6 1/2	5	8	3/4
2 1/2	7	5 1/2	4	3/4	•	3/4	•	3/4	7 1/2	5 7/8	8	7/8
3	7 1/2	6	4	3/4	•	3/4	•	3/4	8 1/4	6 5/8	8	7/8
3 1/2	8 1/2	7	8	3/4	•	3/4	•	•	9	7 1/4	8	7/8
4	9	7 1/2	8	3/4	3/4	3/4	3/4	3/4	10	7 7/8	8	7/8
5	10	8 1/2	8	7/8	3/4	7/8	3/4	7/8	11	9 1/4	8	7/8
6	11	9 1/2	8	7/8	3/4	7/8	3/4	7/8	12 1/2	10 5/8	12	7/8
8	13 1/2	11 3/4	8	7/8	3/4	7/8	3/4	7/8	15	13	12	1
10	16	14 1/4	12	1	3/4	1	3/4	1	17 1/2	15 1/4	16	1 1/8
12	19	17	12	1	3/4	1	3/4	1	20 1/2	17 3/4	16	1 1/4
14	21	18 3/4	12	1 1/8	7/8	1 1/8	7/8	1 1/8	23	20 1/4	20	1 1/4
16	23 1/2	21 1/4	16	1 1/8	7/8	1 1/8	7/8	1 1/8	25 1/2	22 1/2	20	1 3/8
18	25	22 3/4	16	1 1/4	7/8	1 1/4	7/8	1 1/8	28	24 3/4	24	1 3/8
20	27 1/2	25	20	1 1/4	7/8	1 1/4	7/8	1 1/4	30 1/2	27	24	1 3/8
22	29 1/2	27 1/4	20	•	•	1 3/8	7/8	1 3/8	33	29 1/4	24	1 5/8
24	32	29 1/2	20	1 3/8	7/8	1 3/8	7/8	1 3/8	36	32	24	1 5/8
26	34 1/4	31 3/4	24	•	•	1 3/8	7/8	1 3/8	38 1/4	34 1/2	28	1 3/4
28	36 1/2	34	28	•	•	1 3/8	7/8	1 3/8	40 3/4	37	28	1 3/4
30	38 3/4	36	28	1 3/8	1	1 3/8	1	1 1/2	43	39 1/4	28	2*
32	41 3/4	38 1/2	28	•	•	1 5/8	1	1 5/8	45 1/4	41 1/2	28	2
34	43 3/4	40 1/2	32	•	•	1 5/8	1	1 5/8	47 1/2	43 1/2	28	2
36	46	42 3/4	32	1 5/8	1	1 5/8	1	1 5/8	50	46	32	2 1/4*
38	48 3/4	45 1/4	32	•	•	1 5/8	1	1 3/4	56	43	32	1 5/8
40	50 3/4	47 1/4	36	1 5/8	1 1/8	1 5/8	1	1 3/4	48 3/4	45 1/2	32	1 3/4
42	53	49 1/2	36	•	•	1 5/8	1 1/8	1 3/4	57*	52 3/4*	36*	2 1/4*
44	55 1/4	51 3/4	40	•	•	1 5/8	1 1/8	1 3/4	53 1/4	49 3/4	32	1 5/8
46	57 1/4	53 3/4	40	•	•	1 5/8	1 1/8	1 3/4	55 3/4	52	28	2
48	59 1/2	56	44	1 5/8	1 1/8	1 5/8	1 1/8	1 3/4	65*	60 3/4*	40*	2 1/4*
50	61 3/4	58 1/4	44	•	•	1 7/8	1 1/4	1 7/8	60 1/4	56 1/4	32	2 1/8
52	64	60 1/2	44	•	•	1 7/8	1 1/4	1 7/8	62 1/4	58 1/4	32	2 1/8
54	66 1/4	62 3/4	44	2	1 1/8	1 7/8	1 3/8	1 7/8	65 1/4	61	28	2 3/8
56	68 3/4	65	48	•	•	1 7/8	•	1 7/8	67 1/4	63	28	2 3/8
58	71	67 1/4	48	•	•	1 7/8	•	1 7/8	69 1/4	65	32	2 3/8
60	73	69 1/4	52	2	1 1/4	1 7/8	1 3/8	1 7/8	71 1/4	67	32	2 3/8
62	73 3/4	71 3/4	52	•	•	•	•	2				
66	80	76	52	•	•	1 7/8	1 3/8	2				
72	86 1/2	82 1/2	60	2	1 1/4	1 7/8	1 3/8	2				
78*	93	89	64	•	•	2 1/8	1 5/8	•				
84	99 3/4	95 1/2	64	2 1/4	1 3/8	2 1/8	1 5/8	2 1/8				
90*	106 1/2	102	68	•	•	2 3/8	1 7/8	•				
96	113 1/4	108 1/2	68	2 1/4	1 3/8	2 3/8	1 7/8	2 3/8				
102	120	114 1/2	72	•	•	2 5/8	2 1/8	•				
108	126 3/4	120 3/4	72	•	•	2 5/8	2 1/8	•				
120	140 1/4	132 3/4	76	•	•	2 7/8	2 3/8	•				
132	153 3/4	145 3/4	80	•	•	3 1/8	2 5/8	•				
144	167 1/4	158 1/4	84	•	•	3 3/8	2 7/8	•				

*DIMENSION SHOWN DOES NOT MEET SMM SP-44
 Most manufacturers can furnish products meeting the drilling/flange standards of:
 1. British Standard 10:1962
 2. EJMA, Tables 2-3-5-5/1962
 3. ISO, International Std. 2084
 4. ISO, International Std. 2536
 5. NBS Product Standard PS 15-69
 6. API Standard 605
 7. DIN-ND 2501 Tbls 6-10-16
 8. SMS 2033
 9. DIN 2633
 10. RSF 1583
 11. NFE 29-201 PN 6-10-16 and many others.

NOTES: 1. When ordering/specifying: Expansion Joints, Rubber Pipe, Retaining Rings or control Unit Assemblies, always note the mating flange drilling specification or the actual dimensions if specification is unknown. In the absence of this data, these products will be drilled to ANSI B16.1, Class 125 or to the individual manufacturer's printed drilling specification. 2. When products are manufactured to ASTM F1123-87. They should be drilled to ML-F- 20042C or ANSI B16.5, Class 150 as specified by the customer. 3. AWS= American War Standard, ASA= American Standards Association, changed to USAS, USAS=United States of America Standards Institute, changed to ANSI, ANSI= American National Standards Institute, AWWA = American Water Works Association, API = American Petroleum Institute 4. Drilling is available, but not shown for the following: 1914—78", 90"; AWWA C207-78-114", 126", 138".

Option Flange Drilling

Nominal Pipe Size	PN-10 EN 1092-1 (BS4504 - DIN 2501)					PN-25 EN 1092-1 (BS4504 - DIN 2501)					British Standard (BS10:2009)					JIS Standard B-2212 Conforms to JIS10KG/CM				
	Flange Width	Flange OD	Bolt Circle	No. Of Holes	Hole Dia.	Flange Width	Flange OD	Bolt Circle	No. Of Holes	Hole Dia.	Flange Width	Flange OD	Bolt Circle	No. Of Holes	Hole Dia.	Flange Width	Flange OD	Bolt Circle	No. Of Holes	Hole Dia.
1 in	0.63	4.53	3.35	4	0.55	1.10	4.53	3.35	4	0.55	0.59	4.5	3.25	4	0.62	0.59	4.92	3.54	4	0.75
25 mm	15.9	115	85	4	14	28	115	85	4	14	15	114	82.6	4	15.9	15	125	90	4	19
1.25 in	0.63	5.51	3.94	4	0.71	1.18	5.51	3.94	4	0.71	0.59	4.75	3.44	4	0.62	0.59	5.31	3.94	4	0.75
32 mm	16	140	100	4	18	30	140	100	4	18	15	121	87.3	4	15.9	15	135	100	4	19
1.5 in	0.63	5.91	4.33	4	0.71	1.26	5.91	4.33	4	0.71	0.59	5.25	3.88	4	0.62	0.59	5.51	4.13	4	0.75
40 mm	16	150	110	4	18	32	150	110	4	18	15	133	98.4	4	15.9	15	140	105	4	19
2 in	0.71	6.5	4.92	4	0.71	1.34	6.50	4.92	4	0.71	0.63	6	4.5	4	0.75	0.63	6.1	4.72	4	0.75
50 mm	18	165	125	4	18	34	165	125	4	18	16	152	114.3	4	19	16	155	120	4	19
2.5 in	0.71	7.28	5.71	4	0.71	1.50	7.28	5.71	8	0.71	0.71	6.5	5	4	0.75	0.71	6.89	5.51	4	0.75
65 mm	18	185	145	4	18	38	185	145	8	18	18	166	127	4	19	18	175	140	4	19
3 in	0.79	7.87	6.3	8	0.71	1.57	7.87	6.30	8	0.71	0.71	7.25	5.75	4	0.75	0.71	7.28	5.91	8	0.75
80 mm	20	200	160	8	18	40	200	160	8	18	18	184	146	4	19	18	185	150	8	19
3.5 in	•	•	•	•	•	•	•	•	•	•	0.71	8	6.5	8	0.75	0.71	7.68	6.3	8	0.75
90 mm	•	•	•	•	•	•	•	•	•	•	18	203	165	8	19	18	195	160	8	19
4 in	0.79	8.66	7.09	8	0.71	1.73	9.25	7.48	8	0.87	0.71	8.5	7	8	0.75	0.71	8.27	6.89	8	0.75
100 mm	20	220	180	8	18	44	235	190	8	22	18	216	177.8	8	19	18	210	175	8	19
5 in	0.87	9.84	8.27	8	0.71	1.89	10.63	8.66	8	1.02	0.79	10	8.25	8	0.75	0.79	9.84	8.27	8	0.91
125 mm	22	250	210	8	18	48	270	220	8	26	20	254	209.6	8	19	20	250	210	8	23
6 in	0.87	11.22	9.45	8	0.87	2.05	11.81	9.84	8	1.02	0.87	11	9.25	8	0.88	0.87	11.02	9.45	8	0.91
150 mm	22	285	240	8	22	52	300	250	8	26	22	279	235	8	22.2	22	280	240	8	23
8 in	0.87	13.39	11.61	8	0.87	2.05	14.17	12.20	12	1.02	0.87	13.25	11.5	8	0.88	0.87	12.99	11.42	12	0.91
200 mm	22	340	295	8	22	52	360	310	12	26	22	337	292	8	22.2	22	330	290	12	23
10 in	1.02	15.55	13.78	12	0.87	2.36	16.73	14.57	12	1.18	0.95	16	14	12	0.88	0.95	15.75	13.98	12	0.98
250 mm	26	395	350	12	22	60	425	370	12	30	24	406	355.6	12	22.2	24	400	355	12	25
12 in	1.02	17.52	15.75	12	0.87	2.64	19.09	16.93	16	1.18	0.95	18	16	12	1	0.95	17.52	15.75	16	0.98
300 mm	26	445	400	12	22	67	485	430	16	30	24	457	406.4	12	25.4	24	445	400	16	25
14 in	1.1	19.88	18.11	16	0.87	2.83	21.85	19.29	16	1.30	1.02	20.75	18.5	12	1	1.02	19.29	17.52	16	0.98
350 mm	28	505	460	16	26	72	555	490	16	33	26	527	469.9	12	25.4	26	400	445	16	25
16 in	1.18	22.24	20.28	16	1.02	3.07	24.41	21.65	16	1.42	1.1	22.75	20.5	12	1	1.1	22.05	20.08	16	1.06
400 mm	30	565	515	16	26	78	620	550	16	36	28	578	520.7	12	25.4	28	560	510	16	27
18 in	1.18	24.21	22.24	20	1.02	3.31	26.38	23.62	16	1.42	1.18	25.25	23	16	1	1.18	24.41	22.24	20	1.06
450 mm	30	615	565	20	26	84	670	600	16	36	30	641	584.2	16	25.4	30	620	565	20	27
20 in	1.18	26.38	24.41	20	1.02	3.54	28.74	25.98	20	1.42	1.18	27.75	25.25	16	1	1.18	26.57	24.41	20	1.06
500 mm	30	670	620	20	26	90	730	660	20	36	30	705	641.4	16	25.4	30	675	620	20	27
22 in	1.18	38.74	26.57	20	1.18	•	•	•	•	•	1.18	30	27.5	16	1.13	1.18	29.33	26.77	20	1.3
550 mm	30	730	675	20	30	•	•	•	•	•	30	762	698.5	16	28.6	30	745	680	20	33
24 in	1.18	30.71	28.54	20	1.18	3.94	33.27	30.31	20	1.54	1.18	32.5	29.75	16	1.25	1.18	31.3	28.74	24	1.3
600 mm	30	780	725	20	30	100	845	770	20	39	30	826	755.7	16	31.8	30	795	730	24	33
26 in	1.26	32.87	30.75	24	1.18	•	•	•	•	•	•	•	•	•	•	1.26	33.27	30.71	24	1.3
650 mm	32	835	780	24	30	•	•	•	•	•	•	•	•	•	•	32	845	780	24	33
28 in	1.26	32.24	33.07	24	1.18	4.72	37.80	34.45	24	1.65	•	•	•	•	•	1.26	35.63	33.07	24	1.3
700 mm	32	895	840	24	30	120	960	875	24	42	•	•	•	•	•	32	905	840	24	33
30 in	1.26	37.99	35.43	24	1.3	•	•	•	•	•	1.26	39.25	36.5	20	1.38	1.26	38.19	35.43	24	1.3
750 mm	32	965	900	24	33	•	•	•	•	•	32	997	927	20	34.9	32	970	900	24	33

Thorburn Easy-Flex Spherical Expansion Joints



Thorburn Easy-Flex Model 101 single sphere and Model 201 double sphere expansion joint with floating flanges

Thorburn is proud to introduce its precision engineered molded spherical arch expansion joints. Utilizing technology from the tire molding industry, Thorburn’s spherical arch expansion joints are manufactured with multiple plies of tire cord fabric encapsulated with synthetic rubber in a hydraulic rubber press. The result allows for Thorburn’s spherical expansion joints to be constructed with a lighter wall, achieving higher pressure ratings, a lower deflection force, providing greater flexibility and movement absorption.

Applications

- Cold and hot water supply
- Sea water
- Pump pressure lines
- Liquid waste treatment plant
- Compressed air and vacuum line
- Drainage system
- Oil and chemical lines



Thorburn model 201 twin sphere joints installed at a pumping station

Advantages

Long Flowing Arch Design

Reduces turbulence and allows smooth quiet flow. Can not build up solids when suspended in the media and no need for filled arch to restrict movements

Less System Strain

Thorburn’s Easy-Flex spherical expansion joint requires less “force to deflect”, reducing piping flange equipment stress strain-damage.

Absorbs Vibration Noise Shock

Thorburn’s Easy-Flex spherical expansion joint system is an ideal replacement for sound transmitting metallic expansion joints. Sound loses energy travelling axially through the rubber bellows; water hammer, pumping impulses and water-born noises are absorbed by the molded lightweight thin wall structure.

Simplify installation with floating flanges

Thorburn’s Easy-Flex are designed with floating flanges permitting easy mating flange bolt hole alignment.

Thorburn Easy-Flex Colour Coded Spherical Expansion Joints

Offshore and Marine Applications



Thorburn offers a range of spherical rubber expansion joints specifically designed for applications for offshore & marine applications such as engine room oils / fuels, high temperature engine cooling water, potable waterdrilling muds and offshore piping systems.



Compliances & Certifications:

- ASTM F 1123 Flame Retardant
- USA, Canadian & British Coast Guard
- Lloyd’s Register
- DNV GL (Det. Norske Veritas/Germanischer Lloyd)

Easy-Flex 101 Moulded Single Spherical Arch

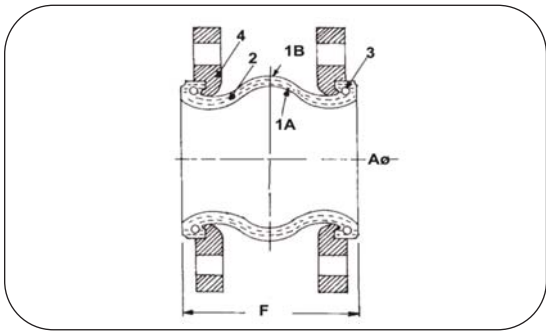

Fig 1 - Maximum Temperature For Pressures Shown

Rubber Types	Maximum Temperature
1" through 4"	135°C
5" through 10"	135°C
12" through 14"	90°C
16" through 20"	65°C
24" through 30"	60°C

Notes:

- Pressure rating is based on operating temperature shown in Fig 1 above. At higher temperatures the pressure rating is reduced. Contact Thorburn for details.
- Pressures shown are recommended "operating". Test pressure is 1.5 times "operating". Burst pressure is minimum 3 times "operating".
- Vacuum rating is based on neutral installed length, without external load. Products should not be installed "extended" on vacuum applications.
- All expansion joints are furnished complete with floating flanges. Drilling meets 125/150/300 lb. standards of ANSI B16.1, B16.24, B16.5; AWWA C207 Class D & F; MSS-SP44 & 51, BS10:2009 (British Standard), JIS B-2212, PN10, PN16, PN25. For drilling information see pages 32 and 33.
- Control units are available. Add Code CR2 or CR3, depending on the number of rods required.
- Dimensions are in inches. All movement in inches.
- XX = Elastomer tube/cover type, please specify.
- Full vacuum 26" Hg specify prefix HD.

Thorburn Code XX	Tube	Cover	Maximum Operating Temperature °F
EE	Butyl	Butyl	225
HH	EPDM	EPDM	300
FC	Hypalon	Neoprene	212
CC	Neoprene	Neoprene	225
DC	Nitrile	Neoprene	212
JC	PTFE (Liner)	Neoprene	170
JH	PTFE (Liner)	EPDM	170
II	FKM	FKM	360

Construction		
Item #	Part	Materials
1A	Tube	Rubber
1B	Cover	Rubber
2	Reinforcement	Nylon/Polyester Tire Cord
3	Wire	Hard Spring Steel Wire
4	Flange	Mild Steel Galvanized Various Materials Available

Flange Drilling (Code Z)	
Code Z	Drilling Type
FL1	ANSI B.16.5 CI 150
FL2	ANSI B16.5 CL 300
FL3	PN10
FL4	PN16
FL5	PN25

Thorburn Part Number	Size		Non-Concurrent Movement				Pressure (See Fig 1)		Weight	
	Nominal Pipe ID (A)	Neutral Length (F)	Axial Compression	Axial Extension	Lateral Deflection	Angular Deflection	Maximum Pressure	Negative Hg	Expansion Joint with Flanges	Control Unit & Rod Set
	inch	inch	inch	inch	inch	Deg	PSI	inch	lbs	inch
101-1-6-XX-Z	1.00	6	0.50	0.38	0.50	37	235	26	3.8	3.3
101-1.25-6-XX-Z	1.25	6	0.50	0.38	0.50	31	235	26	5	3.3
101-1.5-6-XX-Z	1.50	6	0.50	0.38	0.50	27	235	26	6.1	4.6
101-2-6-XX-Z	2.00	6	0.50	0.38	0.50	20	235	26	8.5	6.3
101-2.5-6-XX-Z	2.50	6	0.50	0.38	0.50	17	235	26	12.3	7.6
101-3-6-XX-Z	3.00	6	0.50	0.38	0.50	14	235	26	14	8.3
101-3.5-6-XX-Z	3.50	6	0.50	0.38	0.50	12	235	26	17.6	7.4
101-4-6-XX-Z	4.00	6	0.75	0.50	0.50	14	235	26	18.3	7.4
101-5-6-XX-Z	5.00	6	0.75	0.50	0.50	11	235	26	22.8	8.3
101-6-6-XX-Z	6.00	6	0.75	0.50	0.50	9	235	26	26.8	10.4
101-8-6-XX-Z	8.00	6	0.75	0.50	0.50	7	235	26	40.6	13.4
101-10-8-XX-Z	10.00	8	1.00	0.625	0.75	7	235	26	56.6	21.3
101-12-8-XX-Z	12.00	8	1.00	0.625	0.75	6	235	26	83	27
101-14-8-XX-Z	14.00	8	1.00	0.625	0.75	5	150	22	115	28
101-16-8-XX-Z	16.00	8	1.00	0.625	0.75	4	150	18	165	26.8
101-18-8-XX-Z	18.00	8	1.00	0.625	0.75	4	150	16	168	31.4
101-20-8-XX-Z	20.00	8	1.00	0.625	0.75	3	150	14	170	32.4
101-22-10-XX-Z	22.00	10	1.00	0.625	0.75	3	150	14	210	34.5
101-24-10-XX-Z	24.00	10	1.00	0.625	0.75	3	150	14	255	45.5
101-26-10-XX-Z	26.00	10	1.00	0.625	0.75	3	150	10	305	46.5
101-30-10-XX-Z	30.00	10	1.00	0.625	0.75	2	150	10	405	57

WARNING: Thorburn's Easy-Flex Style 101 spherical arch "Loose fitting" PTFE liner is for positive pressure only.

Ordering information see page 82

Easy-Flex 201 Moulded Dual Spherical Arch

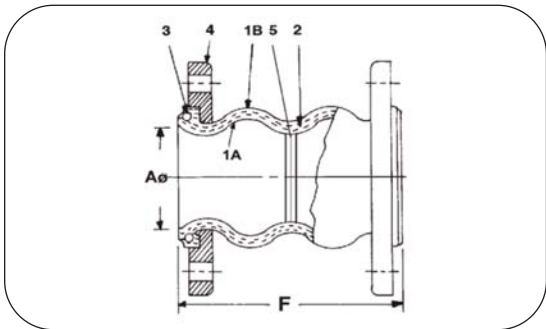

Fig 1 - Maximum Temperature For Pressures Shown

Rubber Types	Maximum Temperature
1" through 4"	135°C
5" through 10"	135°C
12" through 14"	90°C
16" through 24"	65°C
26" through 30"	60°C

Notes:

- Pressure rating is based on operating temperature shown in Fig 1 above. At higher temperatures the pressure rating is reduced. Contact Thorburn for details.
- Pressures shown are recommended "operating". Test pressure is 1.5 times "operating". Burst pressure is minimum 3 times "operating".
- Vacuum rating is based on neutral installed length, without external load. Products should not be installed "extended" on vacuum applications.
- All expansion joints are furnished complete with floating flanges. Drilling meets 125/150/300 lb. standards of ANSI B16.1, B16.24, B16.5; AWWA C207 Class D & F; MSS-SP44 & 51, BS10:2009 (British Standard), JIS B-2212, PN10, PN16, PN25. For drilling information see pages 32 and 33.
- Control units are available. Add Code CR2 or CR3, depending on the number of rods required.
- Dimensions are in inches. All movement in inches.
- XX = Elastomer tube/cover type, please specify.
- Full vacuum 26" Hg specify prefix HD.

Ordering information see page 82

Thorburn Code XX	Tube	Cover	Maximum Operating Temperature °F
EE	Butyl	Butyl	225
HH	EPDM	EPDM	300
FC	Hypalon	Neoprene	212
CC	Neoprene	Neoprene	225
DC	Nitrile	Neoprene	212
II	FKM	FKM	360

Construction		
Item #	Part	Materials
1A	Tube	Rubber
1B	Cover	Rubber
2	Reinforcement	Nylon/Polyester Tire Cord
3	Wire	Hard Spring Steel Wire
4	Flange	Mild Steel Galvanized Various Materials Available

Flange Drilling (Code Z)	
Code Z	Drilling Type
FL1	ANSI B.16.5 CI 150
FL2	ANSI B16.5 CL 300
FL3	PN10
FL4	PN16
FL5	PN25

Thorburn Part Number	Size		Non-Concurrent Movement				Pressure (See Fig 1)		Weight	
	Nominal Pipe ID (A)	Neutral Length (F)	Axial Compression	Axial Extension	Lateral Deflection	Angular Deflection	Maximum Pressure	Negative Hg	Expansion Joint with Flanges	Control Unit & Rod Set
	inch	inch	inch	inch	inch	Deg	PSI	inch	lbs	inch
201-1.25-7-XX-Z	1.25	7	2.00	1.12	1.80	45	235	26	5.2	3.6
201-1.5-7-XX-Z	1.5	7	2.00	1.12	1.80	45	235	26	6.8	4.8
201-2-7-XX-Z	2.0	7	2.00	1.12	1.80	45	235	26	9.0	7.0
201-2.5-7-XX-Z	2.5	7	2.00	1.12	1.80	43	235	26	13.3	8.0
201-3-7-XX-Z	3.0	7	2.00	1.12	1.80	38	235	26	14.3	8.6
201-4-9-XX-Z	4.0	9	2.00	1.38	1.56	34	235	26	20.3	8.0
201-5-9-XX-Z	5.0	9	2.00	1.38	1.56	29	235	26	24.5	8.3
201-6-9-XX-Z	6.0	9	2.00	1.38	1.56	25	235	26	29.5	11.7
201-8-13-XX-Z	8.0	13	2.38	1.38	1.38	19	235	26	43.8	15.4
201-10-13-XX-Z	10.0	13	2.38	1.38	1.38	15	235	26	65.5	24.5
201-12-13-XX-Z	12.0	13	2.38	1.38	1.38	13	235	26	95.0	31.0
201-14-13.75-XX-Z	14.0	13.75	1.75	1.12	1.12	9	150	22	112.0	32.0
201-16-13.75-XX-Z	16.0	13.75	1.75	1.12	1.12	8	150	18	132.0	30.8
201-18-13.75-XX-Z	18.0	13.75	1.75	1.12	1.12	7	150	16	146.0	36.1
201-20-13.75-XX-Z	20.0	13.75	1.75	1.12	1.12	7	150	14	182.0	35.5
201-24-13.75-XX-Z	24.0	13.75	1.75	1.12	1.12	5	150	14	220.0	48.0
201-26-12-XX-Z	28.0	12	1.75	1.12	1.12	5	150	10	243.0	52.0
201-30-12-XX-Z	30.0	12	1.75	1.12	1.12	4	150	10	270.0	62.0

WARNING: Control units must be installed when pressures (test • design • surge • operating) exceed ratings in the above table or piping system is unanchored.

Easy-Flex 110-CR Reducing Spherical Joints - Offshore & Marine

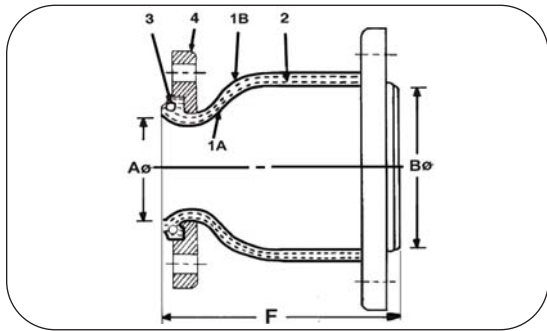

Fig 1 - Maximum Temperature For Pressures Shown

Rubber Types	Maximum Temperature
1" through 4"	135°C
5" through 10"	135°C
12" through 14"	90°C
16" through 20"	65°C
24"	60°C

Notes:

- Pressure rating is based on operating temperature shown in Fig 1 above. At higher temperatures the pressure rating is reduced. Contact Thorburn for details.
- Pressures shown are recommended "operating". Test pressure is 1.5 times "operating". Burst pressure is minimum 3 times "operating".
- Vacuum rating is based on neutral installed length, without external load. Products should not be installed "extended" on vacuum applications.
- All expansion joints are furnished complete with floating flanges. Drilling meets 125/150/300 lb. standards of ANSI B16.1, B16.24, B16.5; AWWA C207 Class D & F; MSS-SP44 & 51, BS10:2009 (British Standard), JIS B-2212, PN10, PN16, PN25. For drilling information see pages 32 and 33.
- Control units are available. Add Code CR2 or CR3, depending on the number of rods required.
- **Dimensions are in DN and mm. All movement in mm.**
- XX = Elastomer tube/cover type, please specify.
- Full vacuum 26" Hg specify prefix HD.

Short Face-to-Face and High Pressure

Thorburn Code XX	Colour Band Option	Tube	Cover	Max. Operating Temperature °F
EE	Black	Butyl	Butyl	225
HH	Red	EPDM	EPDM	300
DD*	White	Nitrile	Nitrile	212
CC	Blue	Neoprene	Neoprene	225
DC	Yellow	Nitrile	Neoprene	212
FF	Green	Hypalon	Hypalon	250
II	Orange	FKM	FKM	360

* Code DD, White Band - For potable water and food grade products

Construction		
Item #	Part	Materials
1A	Tube	Rubber
1B	Cover	Rubber
2	Reinforcement	Nylon/Polyester Tire Cord
3	Wire	Hard Spring Steel Wire
4	Flange	Mild Steel Galvanized Various Materials Available

Flange Drilling (Code Z)	
Code Z	Drilling Type
FL1	ANSI B.16.5 Cl 150
FL2	ANSI B16.5 CL 300
FL3	PN10
FL4	PN16
FL5	PN25

Thorburn Part Number	Size		Non-Concurrent Movement				Pressure (See Fig 1)	
	Nominal Pipe ID (B X A)	Neutral Length (F)	Axial Compression	Axial Extension	Lateral Deflection	Angular Deflection	Maximum Pressure	Negative Hg
110-CR-80X50-180-XX-Z	80(3) X 50(2)	180	30	20	45	35	10	225
110-CR-80X65-180-XX-Z	80(3) X 65(2.5)	180	30	20	45	35	10	225
110-CR-100X50-180-XX-Z	100(4) X 50(2)	180	30	20	45	35	10	225
110-CR-100X80-180-XX-Z	100(4) X 80(3)	180	30	22	45	35	10	225
110-CR-150X100-200-XX-Z	150(6) X 100(4)	200	30	22	45	35	10	150
110-CR-200X100-200-XX-Z	200(8) X 100(4)	200	30	22	40	30	10	150
110-CR-200X150-200-XX-Z	200(8) X 150(6)	200	35	25	40	30	10	150
110-CR-250X150-220-XX-Z	250(10) X 150(6)	220	35	25	40	30	10	150
110-CR-250X200-220-XX-Z	250(10) X 200(8)	220	35	25	40	30	10	150
110-CR-300X200-220-XX-Z	300(12) X 200(8)	220	35	25	40	30	10	75
110-CR-300X250-220-XX-Z	300(12) X 250(10)	220	35	25	40	30	10	75
110-CR-350X250-240-XX-Z	350(14) X 250(10)	240	38	28	35	26	10	75
110-CR-350X300-240-XX-Z	350(14) X 300(12)	240	35	25	40	30	10	75
110-CR-400X200-240-XX-Z	400(16) X 200(8)	240	35	25	40	30	10	75
110-CR-400X250-240-XX-Z	400(16) X 250(10)	240	38	28	40	30	10	75
110-CR-400X300-240-XX-Z	400(16) X 300(12)	240	38	28	40	30	10	75
110-CR-500X400-240-XX-Z	500(20) X 400(16)	240	38	28	40	30	10	75
110-CR-600X400-240-XX-Z	600(24) X 400(16)	240	38	28	40	30	10	75
110-CR-600X500-240-XX-Z	600(24) X 500(20)	240	38	28	40	30	10	75

Ordering information see page 82

Easy-Flex 110 Moulded Single Spherical Arch - Offshore & Marine

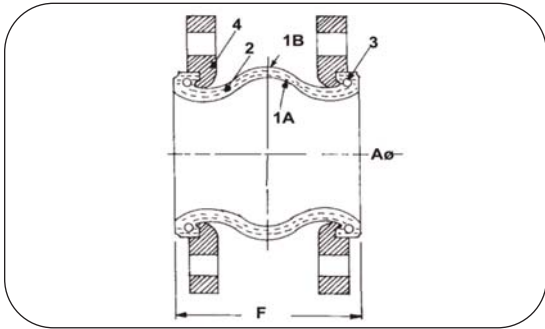

Fig 1 - Maximum Temperature For Pressures Shown

Rubber Types	Maximum Temperature
1" through 4"	135°C
5" through 10"	135°C
12" through 14"	90°C
16" through 20"	65°C
24" through 48"	60°C

Notes:

- Pressure rating is based on operating temperature shown in Fig 1 above. At higher temperatures the pressure rating is reduced. Contact Thorburn for details.
- Pressures shown are recommended "operating". Test pressure is 1.5 times "operating". Burst pressure is minimum 3 times "operating".
- Vacuum rating is based on neutral installed length, without external load. Products should not be installed "extended" on vacuum applications.
- All expansion joints are furnished complete with floating flanges. Drilling meets 125/150/300 lb. standards of ANSI B16.1, B16.24, B16.5; AWWA C207 Class D & F; MSS-SP44 & 51, BS10:2009 (British Standard), JIS B-2212, PN10, PN16, PN25. For drilling information see pages 32 and 33.
- Control units are available. Add Code CR2 or CR3, depending on the number of rods required.
- **Dimensions are in DN and mm. All movement in mm.**
- XX = Elastomer tube/cover type, please specify.
- Full vacuum 26" Hg specify prefix HD.

Short Face-to-Face and High Pressure

Thorburn Code XX	Colour Band Option	Tube	Cover	Max. Operating Temperature °F
EE	Black	Butyl	Butyl	225
HH	Red	EPDM	EPDM	300
DD*	White	Nitrile	Nitrile	212
CC	Blue	Neoprene	Neoprene	225
DC	Yellow	Nitrile	Neoprene	212
FF	Green	Hypalon	Hypalon	250
II	Orange	FKM	FKM	360

* Code DD, White Band - For potable water and food grade products

Construction		
Item #	Part	Materials
1A	Tube	Rubber
1B	Cover	Rubber
2	Reinforcement	Nylon/Polyester Tire Cord
3	Wire	Hard Spring Steel Wire
4	Flange	Mild Steel Galvanized Various Materials Available

Flange Drilling (Code Z)	
Code Z	Drilling Type
FL1	ANSI B.16.5 Cl 150
FL2	ANSI B16.5 CL 300
FL3	PN10
FL4	PN16
FL5	PN25

Thorburn Part Number	Size		Non-Concurrent Movement				Pressure (See Fig 1)	
	Nominal Pipe ID (A)	Neutral Length (F)	Axial Compression	Axial Extension	Lateral Deflection	Angular Deflection	Maximum Pressure	Negative Hg
	DN (in)	mm	mm	mm	mm	mm	bar	mmHg
110-32-95-XX-Z	32 (1.25)	95	15	10	15	20	16	480
110-40-95-XX-Z	40 (1.5)	95	15	10	15	20	16	450
110-50-105-XX-Z	50 (2)	105	20	12	15	20	16	375
110-65-115-XX-Z	65 (2.5)	115	20	12	15	20	16	375
110-80-130-XX-Z	80 (3)	130	20	12	17	20	16	225
110-90-132-XX-Z	90 (3.5)	132	25	17	20	15	16	225
110-100-135-XX-Z	100 (4)	135	25	17	20	15	16	225
110-125-170-XX-Z	125 (5)	170	25	17	20	15	16	225
110-150-180-XX-Z	150 (6)	180	25	20	22	10	16	150
110-200-205-XX-Z	200 (8)	205	25	20	22	10	16	150
110-250-240-XX-Z	250 (10)	240	25	20	22	10	16	150
110-300-260-XX-Z	300 (12)	260	25	20	22	5	16	75
110-350-265-XX-Z	350 (14)	265	25	20	22	4	10	75
110-400-265-XX-Z	400 (16)	265	25	20	22	4	10	75
110-450-265-XX-Z	450 (18)	265	25	20	22	3	10	75
110-500-265-XX-Z	500 (20)	265	25	20	22	3	10	75
110-600-265-XX-Z	600 (24)	265	25	20	22	2	10	75
110-700-265-XX-Z	700 (28)	265	25	20	22	2	6	75
110-800-265-XX-Z	800 (32)	265	25	20	22	2	6	75
110-900-265-XX-Z	900 (36)	265	25	20	22	2	6	75
110-1000-300-XX-Z	1000 (40)	300	30	20	22	2	6	75
110-1200-300-XX-Z	1200 (48)	300	30	20	22	2	6	75

Ordering information see page 82

Easy-Flex 111 Moulded Single Spherical Arch - Offshore & Marine

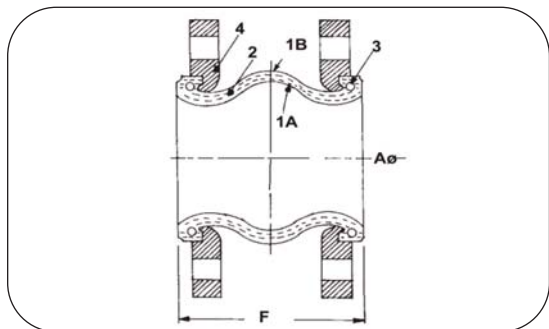

Fig 1 - Maximum Temperature For Pressures Shown

Rubber Types	Maximum Temperature
1" through 4"	135°C
5" through 10"	135°C
12"	90°C

Notes:

- Pressure rating is based on operating temperature shown in Fig 1 above. At higher temperatures the pressure rating is reduced. Contact Thorburn for details.
- Pressures shown are recommended "operating". Test pressure is 1.5 times "operating". Burst pressure is minimum 3 times "operating".
- Vacuum rating is based on neutral installed length, without external load. Products should not be installed "extended" on vacuum applications.
- All expansion joints are furnished complete with floating flanges. Drilling meets 125/150/300 lb. standards of ANSI B16.1, B16.24, B16.5; AWWA C207 Class D & F; MSS-SP44 & 51, BS10:2009 (British Standard), JIS B-2212, PN10, PN16, PN25. For drilling information see pages 32 and 33.
- Control units are available. Add Code CR2 or CR3, depending on the number of rods required.
- **Dimensions are in DN and mm. All movement in mm.**
- XX = Elastomer tube/cover type, please specify.
- Full vacuum 26" Hg specify prefix HD.

Short Face-to-Face and High Pressure

Thorburn Code XX	Colour Band Option	Tube	Cover	Max. Operating Temperature °F
EE	Black	Butyl	Butyl	225
HH	Red	EPDM	EPDM	300
DD*	White	Nitrile	Nitrile	212
CC	Blue	Neoprene	Neoprene	225
DC	Yellow	Nitrile	Neoprene	212
FF	Green	Hypalon	Hypalon	250
II	Orange	FKM	FKM	360

* Code DD, White Band - For potable water and food grade products

Construction		
Item #	Part	Materials
1A	Tube	Rubber
1B	Cover	Rubber
2	Reinforcement	Nylon/Polyester Tire Cord
3	Wire	Hard Spring Steel Wire
4	Flange	Mild Steel Galvanized Various Materials Available

Flange Drilling (Code Z)	
Code Z	Drilling Type
FL1	ANSI B.16.5 Cl 150
FL2	ANSI B16.5 CL 300
FL3	PN10
FL4	PN16
FL5	PN25

Thorburn Part Number	Size		Non-Concurrent Movement				Pressure (See Fig 1)	
	Nominal Pipe ID (A)	Neutral Length (F)	Axial Compression	Axial Extension	Lateral Deflection	Angular Deflection	Maximum Pressure	Negative Hg
	DN (in)	mm	mm	mm	mm	mm	bar	mmHg
111-25-130-XX-Z	25 (1)	130	13	10	13	37	16	660
111-32-130-XX-Z	32 (1.25)	130	13	10	13	31	16	660
111-40-130-XX-Z	40 (1.5)	130	13	10	13	27	16	660
111-50-130-XX-Z	50 (2)	130	10	10	13	20	16	660
111-65-130-XX-Z	65 (2.5)	130	13	10	13	17	16	660
111-80-130-XX-Z	80 (3)	130	13	10	13	14	16	660
111-100-130-XX-Z	100 (4)	130	19	13	13	14	16	660
111-125-130-XX-Z	125 (5)	130	19	13	13	11	16	660
111-150-130-XX-Z	150(6)	130	19	13	13	9	16	660
111-200-130-XX-Z	200 (8)	130	19	13	13	7	16	660
111-250-130-XX-Z	250 (10)	130	25	16	19	7	16	660
111-300-130-XX-Z	300 (12)	130	25	16	19	6	16	660

Ordering information see page 82

Easy-Flex 210 Moulded Dual Spherical Arch - Offshore & Marine

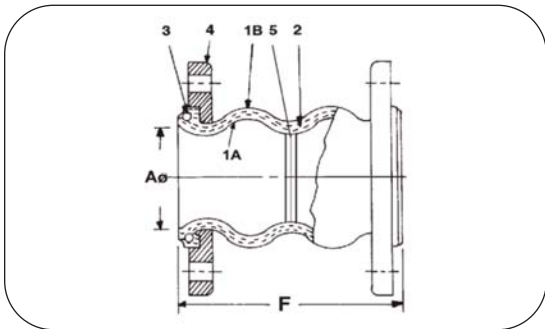

Fig 1 - Maximum Temperature For Pressures Shown

Rubber Types	Maximum Temperature
1" through 4"	135°C
5" through 10"	135°C
12" through 14"	90°C
16" through 20"	65°C

Notes:

- Pressure rating is based on operating temperature shown in Fig 1 above. At higher temperatures the pressure rating is reduced. Contact Thorburn for details.
- Pressures shown are recommended "operating". Test pressure is 1.5 times "operating". Burst pressure is minimum 3 times "operating".
- Vacuum rating is based on neutral installed length, without external load. Products should not be installed "extended" on vacuum applications.
- All expansion joints are furnished complete with floating flanges. Drilling meets 125/150/300 lb. standards of ANSI B16.1, B16.24, B16.5; AWWA C207 Class D & F; MSS-SP44 & 51, BS10:2009 (British Standard), JIS B-2212, PN10, PN16, PN25. For drilling information see pages 32 and 33.
- Control units are available. Add Code CR2 or CR3, depending on the number of rods required.
- **Dimensions are in DN and mm. All movement in mm.**
- XX = Elastomer tube/cover type, please specify.
- Full vacuum 26" Hg specify prefix HD.

Short Face-to-Face and High Pressure

Thorburn Code XX	Colour Band Option	Tube	Cover	Max. Operating Temperature °F
EE	Black	Butyl	Butyl	225
HH	Red	EPDM	EPDM	300
DD*	White	Nitrile	Nitrile	212
CC	Blue	Neoprene	Neoprene	225
DC	Yellow	Nitrile	Neoprene	212
FF	Green	Hypalon	Hypalon	250
II	Orange	FKM	FKM	360

* Code DD, White Band - For potable water and food grade products

Construction		
Item #	Part	Materials
1A	Tube	Rubber
1B	Cover	Rubber
2	Reinforcement	Nylon/Polyester Tire Cord
3	Wire	Hard Spring Steel Wire
4	Flange	Mild Steel Galvanized Various Materials Available

Flange Drilling (Code Z)	
Code Z	Drilling Type
FL1	ANSI B.16.5 Cl 150
FL2	ANSI B16.5 CL 300
FL3	PN10
FL4	PN16
FL5	PN25

Thorburn Part Number	Size		Non-Concurrent Movement				Pressure (See Fig 1)	
	Nominal Pipe ID (A)	Neutral Length (F)	Axial Compression	Axial Extension	Lateral Deflection	Angular Deflection	Maximum Pressure	Negative Hg
	DN (in)	mm	mm	mm	mm	mm	bar	mmHg
210-32-178-XX-Z	32 (1.25)	178	50	30	45	45	16	660
210-40-178-XX-Z	40 (1.5)	178	50	30	45	45	16	660
210-50-178-XX-Z	50 (2)	178	50	30	45	45	16	660
210-65-178-XX-Z	65 (2.5)	178	50	30	45	43	16	660
210-80-178-XX-Z	80 (3)	178	50	30	45	38	16	660
210-100-229-XX-Z	100 (4)	229	50	35	40	34	16	660
210-125-229-XX-Z	125 (5)	229	50	35	40	29	16	660
210-150-229-XX-Z	150 (6)	229	50	35	40	25	16	660
210-200-330-XX-Z	200 (8)	330	60	35	35	19	16	660
210-250-330-XX-Z	250 (10)	330	60	35	35	15	16	660
210-300-330-XX-Z	300 (12)	330	60	35	35	13	16	660
210-350-356-XX-Z	350 (14)	356	45	30	28	9	10	660
210-400-356-XX-Z	400 (16)	356	45	30	28	8	10	660
210-450-356-XX-Z	450 (18)	356	45	30	28	7	10	660
210-500-356-XX-Z	500 (20)	356	45	30	28	7	10	660

WARNING: Control units must be installed when pressures (test • design • surge • operating) exceed ratings in the above table or piping system is unanchored.

Ordering information see page 82

Thorburn Easy-Flex Model 102 & 102-HP Rubber Union Connector

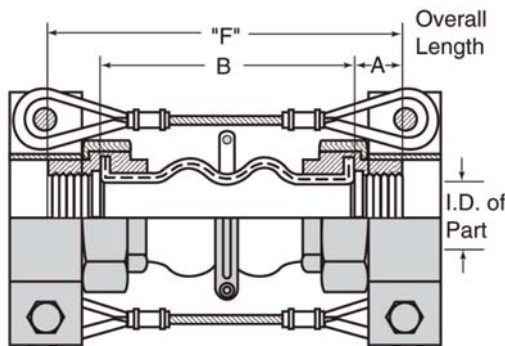

Thorburn's Model 102 standard union connector comes with control cables for added protection and to prevent over-extending leakage during start-up

Thorburn's Model 102 & 102-HP twin sphere female metal threaded union rubber connectors isolate against the transfer of noise and vibration from vibrating equipment to piping line, prevent stresses due to expansion and contraction, and compensate for misalignment. The connectors reduce objectionable noise and vibration in piping systems connected to pumps, chillers, fan coil units, air handling units, compressors, and similar pulsating equipment.

Recommended for pumps and circular pumps, fan coil units, air handling units and pipe line at the building joints. The flexible connectors eliminate stresses caused by changes in temperature and piping misalignment, as well as reduce the transmission of noise and vibration. They are used on both hot and chilled water circulation lines, suction and discharge sides of pumps, and header connections.

Advantages

- Easy to install
- Absorbs pipe wall and fluid borne noise
- Reduces system stress and strain / Compensates for misalignment
- Prevents electrolysis and electrolytic corrosion
- Isolates vibration and motion

Pressure				
Thorburn Model	Max Operating Pressure		Min Operating Pressure	
	Positive PSIG	Negative In of Hg	Test PSIG	Burst PSIG
102	150	26	225	600
102HP	250	26	375	1000

Material Codes	Tube Elastomer	Cover Elastomer	Max Operating Temperature °F
EE	Butyl	Butyl	250
HH	EPDM	EPDM	250
FC	Hypalon	Neoprene	212
CC	Neoprene	Neoprene	225
DC	Nitrile	Neoprene	212
II	FKM	FKM	250

Material Codes	Union/Flange Materials
Standard	Ductile Iron, Galvanized
S4	SS304
S6	SS306
B	Bronze

Thorburn Part Number	Size		Non-Concurrent Movement				Dimensions		Weight
	Nominal Pipe ID (Inches)	Overall Length (Inches)	Axial Compression	Axial Extension	Lateral Deflection	Angular Deflection	Length of Fitting	Length of Rubber	With Unions Installed
	A	F	inch	inch	inch	Deg	B	C	lbs
102-12-XX	0.75	8	0.87	0.23	0.87	32.2	1.06	5.88	1.6
102-12HP-XX	0.75	7	0.75	0.23	0.63	32.2	1.06	4.88	1.7
102-16-XX	1.00	8	0.87	0.23	0.87	25.3	1.14	5.72	2.6
102-16HP-XX	1.00	7	0.75	0.23	0.63	25.3	1.14	4.72	2.7
102-20-XX	1.25	8	0.87	0.23	0.87	20.7	1.26	5.48	3.3
102-20HP-XX	1.25	7	0.75	0.23	0.63	20.7	1.26	4.48	3.4
102-24-XX	1.50	8	0.87	0.23	0.87	17.5	1.30	5.40	4.0
102-24HP-XX	1.50	7	0.75	0.23	0.63	17.5	1.30	4.40	4.1
102-32-XX	2.00	8	0.87	0.23	0.87	13.3	1.42	5.16	5.5
102-32HP-XX	2.00	7	0.75	0.23	0.63	13.3	1.42	4.16	5.6

XX: Suffix material code. Please note Model 102HP is a special expansion joint. Please check delivery before ordering.

Ordering information see page 82

Thorburn Series TM21 Molded Full Face Rubber Flange Expansion Joints

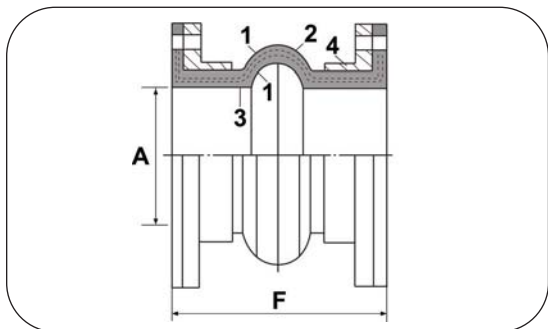

Fig 1 - Maximum Temperature For Pressures Shown

Rubber Types	Maximum Temperature
1" through 4"	135°C
5" through 10"	135°C
12" through 14"	90°C
16" through 24"	65°C
26" through 30"	60°C

Fig 2 - Operating Conditions

NB	WP	BP
2" through 12"	16 kg/cm ²	64 kg/cm ²
14" through 20"	10 kg/cm ²	40 kg/cm ²
24"	6 kg/cm ²	24 kg/cm ²

Notes:

- Pressure rating is based on operating temperature shown in Fig 1 above. At higher temperatures the pressure rating is reduced. Contact Thorburn for details.
- Pressures shown are recommended "operating". Test pressure is 1.5 times "operating". Burst pressure is minimum 4 times "operating".
- Vacuum rating is based on neutral installed length, without external load. Products should not be installed "extended" on vacuum applications.
- All expansion joints are furnished complete with "L" shaped backing rings. Drilling meets 125/150 lb. standards of ANSI B16.1, B16.24, B16.5; AWWA C207 Class D & F; MSS-SP44 & 51.
- Control units are available. Add Code CR2 or CR3, depending on the number of rods required.
- Dimensions are in inches. All movement in inches.
- XX = Elastomer tube/cover type, please specify.

Ordering information see page 82

Thorburn Style TM21 wide arch expansion joints are interchangeable with and replaces handcrafted spool type expansion joints. The arch is much wider than a conventional spool arch type joint which provides for greater movement. The TM21 is typically used for positive pressure which is contained with integral "L" shaped retaining rings on the rubber flange but can also be used for limited vacuum service. TM21 is available with a filled arch design that reduces movement by 50%. Flat face flanges integral to the body mate to 125/150# flanges.

Short Face-to-Face and High Pressure

Thorburn Code XX	Color Band Option	Tube	Cover	Max. Operating Temp. °F
EE	Black	Butyl	Butyl	225
HH	Red	EPDM	EPDM	300
DC	Yellow	Nitrile	Neoprene	212
CC	Blue	Neoprene	Neoprene	225
FF	Green	Hypalon	Hypalon	250
II	Orange	FKM	FKM	360

Construction		
Item #	Part	Materials
1	Body	Butyl, EPDM, CR, NBR, CSM
2	Reinforcement	Nylon/Polyester Tire Cord
3	Wire	Hard Spring Steel Wire
4	Split Retaining Rings	Casting Malleable Iron Flanges

Flange Drilling (Code Z)	
Code Z	Drilling Type
FL1	ANSI B.16.5 CI 150
FL2	ANSI B16.5 CL 300

Thorburn Part Number	Size		Non-Concurrent Movement				Pressure (See Fig 1)	
	Nominal Pipe ID (A)	Neutral Length (F)	Axial Compression	Axial Extension	Lateral Deflection	Angular Deflection	Maximum Pressure	Negative Hg
	inch	inch	inch	inch	inch	Deg	bar	mm
TM21-2-6-XX-Z	2.0	6	25	16	16	25	16	380
TM21-2.5-6-XX-Z	2.5	6	25	16	16	20	16	380
TM21-3-6-XX-Z	3.0	6	25	16	16	18	16	380
TM21-4-6-XX-Z	4.0	6	25	16	16	15	16	380
TM21-5-6-XX-Z	5.0	6	25	16	16	10	16	380
TM21-6-6-XX-Z	6.0	6	25	16	16	8	16	380
TM21-8-6-XX-Z	8.0	6	25	16	16	6	16	380
TM21-10-8-XX-Z	10.0	8	25	16	16	5	16	380
TM21-12-8-XX-Z	12.0	8	25	16	16	4	16	380
TM21-14-8-XX-Z	14.0	8	25	16	16	3	10	250
TM21-16-8-XX-Z	16.0	8	25	16	16	3	10	250
TM21-18-8-XX-Z	18.0	8	25	16	16	2	10	250
TM21-20-8-XX-Z	20.0	8	25	16	16	2	10	250
TM21-24-8-XX-Z	24.0	8	25	16	16	2	6	250

Thorburn's 301EF Ultra High Pressure Rubber Expansion Joints



Interlocking Swivel Flanges

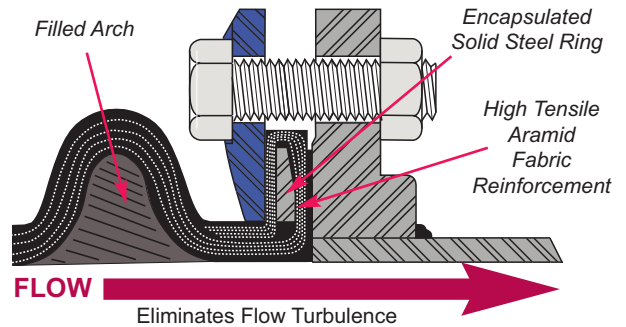

Style 301EF ultra-high pressure 600mm (24") ID expansion joint being hydrostatically tested to 37 bar (540 psi)

Thorburn's Custom Made - Hand Built Spherical Expansion Joints



Easy-Flex 301EF Double Arch Rubber Expansion Joint

Easy-Flex 301EF PTFE Lined Single Arch Rubber Expansion Joint

High Pressure Sealing Force

Thorburn's Style 301EF employs a solid steel ring that is wrapped in high tensile aramid fabric reinforcement at the base of the rubber flange. The solid steel ring stops the aramid fabric reinforcement from "pulling out" of the flanges, a common problem with inferior sphere type rubber expansion joints. The solid steel ring also provides superior sealing force when compressed against the mating flange during installation. This feature prevents the distortion of sealing surfaces if the installation tolerances are exceeded, maintaining a leak tight seal and a high pressure sealing force. Thorburn's Style 301EF expansion joint ID is equal to the pipe ID. This feature combined with swivel flanges and superior sealing force make it ideally suited for HDPE piping systems and mating up to raised faced flanges.

Easy-Flex 301EF-CR & 301EF-ER Concentric & Eccentric Reducers

Thorburn's Style 301EF Concentric and Eccentric reducer expansion joints are specifically developed to connect piping of unequalled diameters. These reducers were designed to replace and address the limitations found in metal reducers in a pipeline.

Thorburn Easy-Flex 301EF-CR Double Arch Concentric Reducer

NPS	Face-To-Face			Design Movement For Single Open Arch				Working Pressure
	1 Arch	2 Arches	3 Arches	Axial Compression	Axial Extension	Lateral Deflection	Angular	
inch	inch	inch	inch	inch	inch	inch	deg	psi
2 X 1.5	6	10	14	1.25	0.75	0.75	26.0	250
3 X 2	6	10	14	1.25	0.75	0.75	24.0	250
4 X 3	7	11	15	1.25	0.75	0.75	20.0	250
5 X 4	8	12	16	1.25	0.75	0.75	19.0	250
6 X 5	9	13	17	1.25	0.75	0.75	15.0	250
8 X 6	11	15	19	1.25	0.75	1.00	12.0	250
10 X 8	12	16	20	1.25	0.75	1.00	10.0	250
12 X 10	14	18	22	1.75	0.75	1.00	9.0	250
14 X 12	14	18	22	1.75	0.75	1.00	8.0	250
16 X 14	16	20	24	1.75	0.75	1.00	7.0	250
18 X 16	16	20	24	1.75	0.75	1.00	6.0	180

Note: 1. For movement compatibility see Technical Data 2. Other size configurations available
3. Available with Filled Arches 4. Full Vacuum rating for all sizes

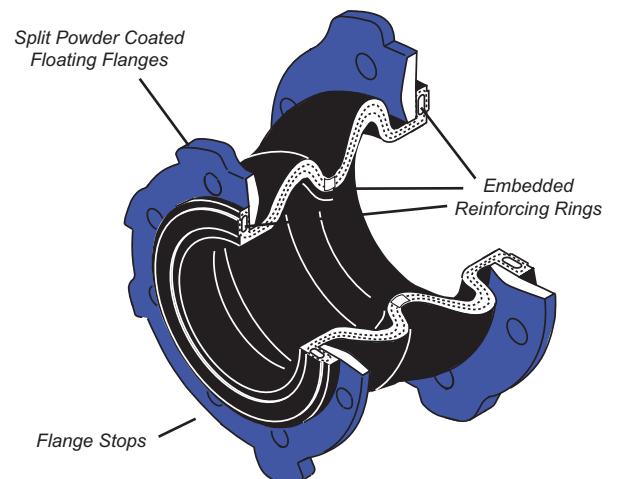

Ordering information see page 82



301EF Series Technical Data

Thorburn's Easy-Flex 301EF series have interlocking swivel flanges which provide leak tight sealing when mated to lap-joint stub ends, raised face, flat full face or odd shaped (butterfly) flanges. Standard floating flanges are drilled as per ANSI B16.5 Class 150, Class 300, PN10, PN20, PN50 epoxy-coated carbon steel. Sizes from DIN40 (1 1/2") to 1200mm (48"), pressures less than 600mm (24") 20 bar (300 psi), 750mm (30") to 1200mm (48") 16 bar (225 psi). Ultra high pressures exceeding 30bar (435psi) available in sizes under 900mm (36"). Rated full vacuum for all sizes. Double & triple arch expansion joints are available for greater movement and lower spring rates. Sizes up to 3.6m (144")

Ordering information see page 82

NPS	Face-To-Face			Design Movement For Single Open Arch					Spring Rate For Single Open Arch				Working Pressure	Working Pressure 4 to 1 Safety Factor
	1 Arch	2 Arches	3 Arches	Axial Compression	Axial Extension	Lateral Deflection	Angular	Torsional	Axial Compression	Axial Extension	Lateral	Angular		
inch	inch	inch	inch	inch	inch	inch	deg	deg	lb/in	lb/in	lb/in	lb*in/deg	psi	lbs
1.5	6	12	16	1.75	0.75	0.75	26.0	2.0	265	344	398	0.11	300	12
2	6	12	16	1.75	0.75	0.75	24.0	2.0	317	413	476	0.23	300	15
2.5	6	12	16	1.75	0.75	0.75	22.0	2.0	398	517	596	0.38	300	17
3	6	12	16	1.75	0.75	0.75	20.0	2.0	506	659	760	0.60	300	19
4	6	12	16	1.75	0.75	0.75	19.0	2.0	636	827	954	1.4	300	23
5	6	12	16	1.75	0.75	0.75	15.0	2.0	769	1,000	1,154	2.8	300	25
6	6	12	16	1.75	0.75	1.00	12.0	2.0	904	1,175	1,356	4.8	300	29
8	6	12	18	1.75	0.75	1.00	10.0	2.0	1,049	1,363	1,573	9.5	300	36
10	8	16	20	1.75	0.75	1.00	9.0	2.0	1,196	1,556	1,795	18.2	300	51
12	8	16	20	1.75	0.75	1.00	8.0	2.0	1,346	1,751	2,020	32	300	72
14	8	16	20	1.75	0.75	1.00	7.0	2.0	1,504	1,955	2,256	44	300	81
16	8	16	20	1.75	0.75	1.00	6.0	2.0	1,661	2,160	2,492	57	300	94
18	8	16	20	1.75	0.75	1.00	6.0	2.0	1,823	2,369	2,734	80	300	105
20	8	16	20	1.75	0.75	1.00	5.0	2.0	1,969	2,560	2,954	114	300	123
22	10	16	22	1.75	0.75	1.00	5.0	2.0	2,111	2,745	3,167	154	300	135
24	10	16	22	1.75	1.00	1.00	5.0	2.0	2,239	2,911	3,359	206	300	157
26	10	16	22	1.75	1.00	1.00	4.0	2.0	2,381	3,096	3,572	219	200	182
28	10	16	22	1.75	1.00	1.00	4.0	2.0	2,532	3,292	3,798	287	200	189
30	10	16	22	1.75	1.00	1.00	4.0	2.0	2,687	3,493	4,030	328	200	207
32	10	16	22	1.75	1.00	1.00	4.0	2.0	2,827	3,675	4,241	417	200	229
34	10	16	22	1.75	1.00	1.00	3.0	2.0	3,002	3,902	4,502	484	200	256
36	10	18	22	2.25	1.00	1.00	3.0	2.0	3,164	4,112	4,745	633	200	285
40	10	18	22	2.25	1.00	1.00	3.0	2.0	3,326	4,325	4,990	782	200	324
42	12	18	22	2.25	1.00	1.00	3.0	2.0	3,534	4,595	5,301	872	200	347
48	12	18	22	2.25	1.00	1.00	3.0	2.0	3,740	4,862	5,611	1,369	200	452

301EFS- Short Face-To-Face

1.5	4	7	12	0.438	0.250	0.438	18.5	2.0	255	338	203	0.17	300	11
2	4	7	12	0.438	0.250	0.438	14.5	2.0	338	420	255	0.35	300	14
2.5	4	7	12	0.438	0.250	0.438	10.0	2.0	420	521	315	0.54	300	16
3	4	7	12	0.438	0.250	0.438	7.5	2.0	503	621	375	0.9	300	18
4	4	7	12	0.438	0.250	0.438	6.0	2.0	608	828	548	2.1	300	21
5	4	7	12	0.438	0.250	0.438	5.5	2.0	840	1032	675	4.2	300	24
6	4	7	12	0.438	0.250	0.438	5.0	2.0	1050	1239	795	7.2	300	28
8	5	9	14	0.688	0.375	0.500	4.5	2.0	1133	1379	885	14.3	300	33
10	5	9	14	0.688	0.375	0.500	4.0	2.0	1440	1722	1095	27.3	300	47
12	5	9	14	0.688	0.375	0.500	3.75	2.0	1725	2067	1305	48	300	66

Note: Flange dimensions are in accordance with 125/150 pound standard drilling of: ANSI B16.1, B16.24, B16.51, MSS SP-44. Other flange types available upon request.

Special notes on movement capability: 1) Filled arch construction reduces above movements by 50%. 2) To calculate movement of multiple arch type for compression extension and lateral movements, take movement shown in the above table and multiply by the number of arches. 3) The degree of angular movement is based on the maximum extension shown. 4) Movement capability shown is non-concurrent percentage used in one movement position and must be deducted from the other movement position so that sum of movements doesn't exceed 100%. 5) Movements shown are based on proper installation practices. See Thorburn installation maintenance guide for details.

Special notes on Spring Rates: 1) Forces required to move Thorburn Easy-Flex 301EF are based on zero pressure conditions and room temperature in the pipeline. 2) These forces should be considered only as approximates, compensation must be made for more accurate forces based on materials of construction and actual service conditions. 3) Filled arch spring rates are approximately 4 times that of a single open arch. 4) Multi-arch spring rates are equal to a single arch divided by number of arches.



Thorburn's Tef-Flex Model 4TF3 PTFE Expansion Joints with axial movement limiting sleeve

Tef-Flex PTFE Expansion joints

Thorburn's Tef-Flex, is a molded PTFE expansion joint which has been specifically designed for piping systems requiring the transfer of corrosive medias at higher pressures and temperatures. Thorburn's Tef-Flex provides tremendous flex life and unmatched reliability. The unpigmented virgin PTFE properties of Tef-Flex increase its physical properties, adding strength, impermeability and stability at high temperatures. Only known chemicals to react with Tef-Flex are molten alkali metals, liquid or gaseous fluorine. The low spring rate of the Tef-Flex joints is critical when mating to stress-sensitive process equipment (glass-lined steel, glass, FRP, Haveg™, graphite, etc.)

Optional Top Hat Liner

Top hat liner inserted through the Tef-Flex expansion joint is recommended when the media contains solids or the fluid velocity is high (steam).

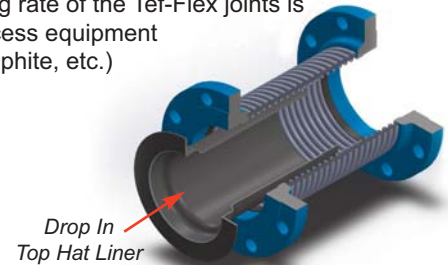

Instantaneous Spring Rate at 70°F

Size	Force Pounds for 1/8" Axial Movement			Force Pounds for 1/8" Lateral Deflection			Force lbs * inches per Degree		
	2 Conv	3 Conv	5 Conv	2 Conv	3 Conv	5 Conv	2 Conv	3 Conv	5 Conv
1	50	25	5	62.5	50	25	0.7	0.4	0.1
1.5	55	30	15	75	62.5	33.8	3.0	2.0	1.0
2	70	42	25	125	87	50	4.0	3.0	1.0
3	90	60	40	162	125	56	11	8.0	5.0
4	110	80	50	237	166	80	26	18	11
6	146	105	69	350	269	144	77	56	37
8	173	122	80	475	350	212	166	116	74
10	198	140	90	594	437	287	290	209	133
12	218	152	96	713	525	350	462	281	211
14	227	160	101	835	612	425	654	462	287
16	240	168	106	956	706	500	857	643	428
18	252	173	108	1068	788	563	1187	848	576
20	258	178	110	1187	875	631	1535	1070	651
24	266	181	112	1425	1062	777	2251	1527	964



Spring Rate Temperature Correction Factors

Two factors will lower the spring rate of a Tef-Flex:

- 1. Temperature effect:** Tef-Flex spring rate changes as the temperature rises. *Please see chart*
- 2. Time effect:** The instantaneous spring rate after 24hrs of operation drops by 50%. Continued loading will further reduce spring rate but at a slower rate.

Temperature		Multiplying Factor
°F	°C	
70	21	1.00
100	38	0.65
212	100	0.48
250	121	0.39
300	149	0.32
342	172	0.25
400	204	0.19

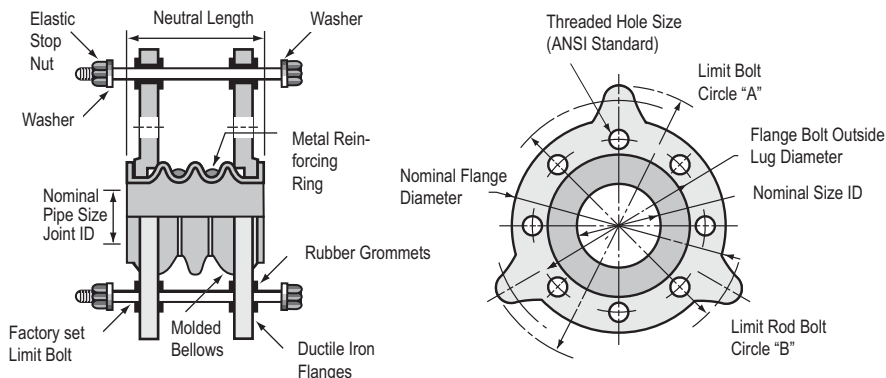

Description	Materials of Construction	
	1" Through 12"	14" Through 24"
Bellows	PTFE T-62	PTFE T-62
Flanges	Ductile Iron	Zinc Plated Carbon Steel
Reinforcing Rings	Stainless Steel	Stainless Steel
Limit Bolts	Carbon Steel	Carbon Steel
Nuts	Carbon Steel	Carbon Steel
Grommets	Neoprene	Neoprene
Washers	Carbon Steel	Carbon Steel

Tef-Flex Movement, Weight & Flange Data

Nominal Pipe Size (in)	Thrust Factor (Mean Diam. sq.in)	2 Convolutions						3 Convolutions					5 Convolutions						
		Part No.	Natural Length (in)	Movement			Weight (lb)	Part No.	Natural Length (in)	Movement			Weight (lb)	Part No.	Natural Length (in)	Movement			Weight (lb)
				Axial (in)	Lateral (in)	Angular (in)				Axial (in)	Lateral (in)	Angular (in)				Axial (in)	Lateral (in)	Angular (in)	
1.5	4.6	1.5TF2	1.375	0.250	0.125	19	3	1.5TF3	2.000	0.500	0.250	38	4	1.5TF5	3.500	0.750	0.500	57	5
2	7.07	2TF2	1.563	0.250	0.125	14	7	2TF3	2.750	0.750	0.375	43	8	2TF5	4.000	1.000	0.500	57	9
2.5	9.62	2.5TF2	2.250	0.313	0.125	14	10	2.5TF3	3.188	0.750	0.375	34	11	2.5TF5	4.600	1.000	0.500	46	12
3	15.9	3TF2	2.250	0.375	0.188	14	10	3TF3	3.625	1.000	0.500	38	13	3TF5	5.000	1.250	0.625	38	14
4	23.75	4TF2	2.625	0.500	0.250	14	18	4TF3	3.625	1.000	0.500	29	19	4TF5	5.250	1.250	0.625	36	20
5	33.17	5TF2	2.760	0.500	0.250	11	24	5TF3	4.000	1.000	0.500	23	25	5TF5	6.000	1.250	0.625	29	26
6	50.24	6TF2	3.250	0.500	0.250	10	29	6TF3	4.000	1.125	0.500	21	30	6TF5	6.000	1.250	0.625	24	31
8	83.49	8TF2	4.000	0.500	0.250	7	47	8TF3	6.000	1.125	0.500	18	49	8TF5	8.000	1.250	0.625	18	51
10	108.38	10TF2	5.250	0.500	0.250	6	64	10TF3	7.000	1.180	0.500	14	87	10TF5	8.750	1.250	0.625	14	69
12	176.63	12TF2	6.000	0.500	0.250	5	115	12TF3	7.875	1.180	0.625	11	119	12TF5	9.000	1.375	0.750	13	123
14	233.59	14TF2	6.313	0.750	0.375	6	126	14TF3	8.500	1.250	0.625	10	132	14TF5	12.790	1.375	0.750	11	138
16	259.68	16TF2	7.000	1.000	0.375	7	159	16TF3	9.188	1.375	0.750	10	169	16TF5	13.500	1.625	1.000	12	179
18	321.9	18TF2	8.000	1.000	0.375	6	174	18TF3	11.063	1.375	0.750	9	187	18TF5	15.500	1.625	1.000	10	200
20	374.57	20TF2	9.000	1.000	0.375	6	183	20TF3	12.875	1.375	0.875	8	200	20TF5	20.500	1.625	1.250	9	217
24	538.36	24TF2	10.00	1.000	0.375	5	280	24TF3	13.875	1.375	0.875	7	309	24TF5	21.750	1.625	1.250	8	338

Tef-Flex Temperature & Pressure Data - Single Ply Bellows

Nom Pipe Size (in)	Model TF2 (2 Convolutions) Pressure at Temperature (psig) @°F								Vacuum	Model TF3 (3 Convolutions) Pressure at Temperature (psig) @°F								Vacuum	Model TF5 (5 Convolutions) Pressure at Temperature (psig) @°F							
									Hg (29.9°) @ Temp°F									Hg (29.9°) @ Temp°F								
	70	100	150	200	250	300	350	400		70	100	150	200	250	300	350	400		70	100	150	200	250	300	350	400
1.5	170	156	145	120	111	97	85	68	275	121	107	99	64	57	50	43	40	275	74	70	60	43	37	29	21	20
2	170	156	145	120	111	97	85	68	275	121	107	99	64	57	50	43	40	275	74	70	60	43	37	29	21	20
2.5	170	156	145	120	111	97	85	68	275	121	107	99	64	57	50	43	40	275	74	70	60	43	37	29	21	20
3	170	156	145	120	111	97	85	70	275	121	107	99	64	57	50	43	40	275	74	70	60	43	37	29	21	20
4	170	156	145	120	111	97	85	70	275	121	107	99	64	57	50	43	40	275	74	70	60	43	37	29	21	20
5	170	156	145	120	111	97	85	70	275	121	107	99	64	57	50	43	40	275	74	70	60	43	37	29	21	20
6	170	156	145	120	111	97	85	70	275	121	107	99	64	57	50	43	40	275	74	70	60	43	37	29	21	20
8	156	142	128	101	97	85	78	64	150	99	85	71	54	50	40	36	32	150	68	60	50	40	31	26	21	17
10	107	99	90	71	64	55	46	40	150	85	71	60	44	41	35	32	30	150	54	46	40	33	28	21	19	18
12	107	99	90	71	64	55	46	40	80	85	71	60	44	41	35	32	30	80	54	46	40	33	28	21	19	18
14	70	59	48	40	35	30	26	22	10"@212	85	73	55	46	35	32	30	26	10"@212	52	43	33	26	21	20	18	16
16	70	59	48	40	35	30	26	22	10"@212	62	51	40	33	25	22	18	15	10"@212	37	31	24	19	18	16	14	12
18	70	59	48	40	35	30	26	22	9"@212	62	51	40	33	25	22	18	15	9"@212	37	31	24	19	18	16	14	12
20	70	59	48	40	35	30	26	22	6"@212	43	36	29	22	18	16	13	14	6"@212	26	20	16	15	13	12	10	9
24	70	59	48	40	35	30	26	22	4"@212	43	36	29	22	18	14	13	11	4"@212	26	20	16	15	12	10	9	8

Notes: 1. 2 ply bellows doubles WP at temperature 2. Minimum 4 to 1 safety factor. 3. Custom sizes and length available 4. Higher working pressure available 5. Model TF5 not recommended for vacuum service - Use Hot-Flex **WARNING:** Operating Tef-Flex at conditions beyond pressure temperature curve may result in premature failure and/or rupture thus causing property damage or personal injury. Please consult Thorburn Engineering if pressures and temperatures exceed those shown above. Thorshields (See Page 34) must be used at all times in hazardous service to protect against serious personal injury in the event of expansion joints failure. Liner sleeves must be used in abrasive service or where sharp-edged solids are or may be present.

How to Order Thorburn Tef-Flex Expansion Joints

Part Number Example & Description

(Part number must follow the order listed below)

4TF3-LM-I10

4TF3 = Tef-Flex 4 Inch Pipe Size with 3 Convolutions

LM = Metal Top Hat Liner

I10 = Inconel 625 Material

Part Number Codes:

Model: TF2 (2 convolutions)¹
TF3 (3 convolutions)¹
TF5 (5 convolutions)¹

Liner: L (PTFE /FEP)²
LM Metal Top Hat Liner (Specify Material)³

Option: Use suffix "X" and Specify

- Standard construction materials, see page 46 for details
- PTFE used for sizes less than 14" FEP used for sizes greater than 14"
- Metallc material codes: S4 (SS304), S6 (SS316), I10 (Inconel 625)

Thorburn's Hot-Flex "HF" Series PTFE Lined Metallic Expansion Joints

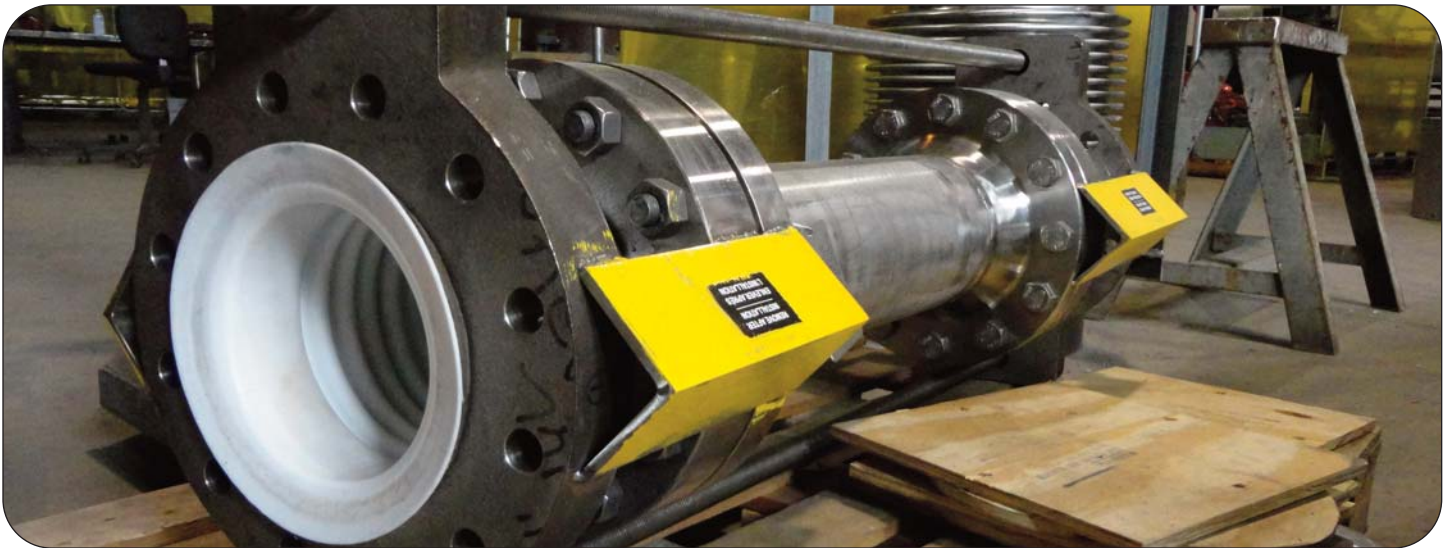

Thorburn's Hot-Flex high pressure PTFE lined expansion joint system with tangent pipe

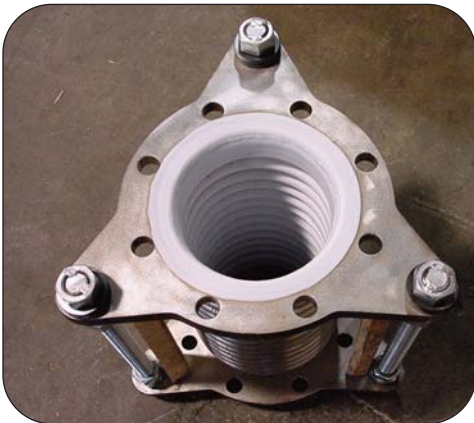

Thorburn's Hot-Flex with isostatically molded unpigmented PTFE convolutions



Hot-Flex expansion joint PTFE liner undergoing a 10,000 Volt spark test to detect pin holes

High Pressure /Temperature & Corrosive Resistant

Thorburn's Hot-Flex "HF" Series PTFE lined expansion joint system is an engineered product that was specifically designed to provide high pressure/temperature transfer containment of highly corrosive media that could not be safely handled by conventional metallic, elastomeric or teflon expansion joints.

Thorburn's Hot-Flex PTFE lined expansion joints combine the high pressure rating of a metallic expansion joint with the high temperature corrosion resistance of PTFE, creating a product that will outperform them both.

Each Hot-Flex PTFE lined expansion joint can be custom engineered to your specific application: pressure/temperature rating, spring rate movement (axial, lateral and angular), metallic carcass (stainless steel, monel, inconel, hasteloy, etc.), various face-to-face dimensions. Available in hinged, gimbal, pressure balanced or tied universal designs.

Advantages

- Absorbs pipe movement
- Isolates mechanical vibration
- Reduced System Noise
- Compensates Misalignment
- Protects against start-up & surge forces



Hot-flex installed in a sulphuric acid transfer line

For ordering information, please contact Thorburn for details

Thorburn Series RLB Rubber Lined Metallic Expansion Joints



Thorburn's Dual Flex Model RLB-DFT - Tied Universal Rubber Lined Metallic Expansion Joint System for the SUNCOR fort Hills Project. Design pressure 35 bar (550 psi) test pressure 53 bar (800 psi)

Thorburn Series RLB Rubber Lined Metallic Expansion Joints

Full vacuum to 70 bar (1000psi), Sizes 100mm to 4000mm - CRN (Canada)

Thorburn's RLB Series rubber lined metallic expansion joints are specifically designed to address pipe movement requirements in high pressure applications that exceed the capabilities of Thorburn's 42HPXX Series rubber expansion joints. Thorburn's RLB Series incorporates the security of using ASME code allowable stress values to calculate pressure containment & movement capabilities of a metallic expansion joint while combining the superior abrasion, erosion and corrosion resistance of a rubber expansion joint. This combination yields a superior expansion joint to a stand alone metallic or rubber expansion joint.

RLB Series rubber lined metallic expansion joint uses 3 proven technologies

Lining metal pipes with rubber is a technology that has been in service in mines for over a century to handle abrasion, erosion & corrosion problems. Low density rubber filled arches in rubber expansion joints to provide smooth unimpeded flow is a technology that was perfected in the 1930's. Thorburn's RLB rubber lined metallic expansion joints are an innovation of combining three proven technologies (metallic expansion joints, rubber lining of metallic surfaces & low density rubber filled expansion joint arches) to address high pressure pipe motion problems found in transferring slurry and bitumen to tailing processing facilities.

Thorburn Series RLB Features

- Provides smooth unobstructed flow
- Abrasive resistant to fine & coarse media
- Relieves stress in piping systems
- ASME B31.1 & B31.3 compliant
- CRN for all Canadian Provinces

Media Compatibility (HNBR/FKM Lining)

Chemically inert & resistant to isopentane, & N-Pentane solvents, Bitumen - Maltene & Bitumen - Asphaltene, H2O & Air



RLB-SF Rubber Lined Metallic Expansion Joint

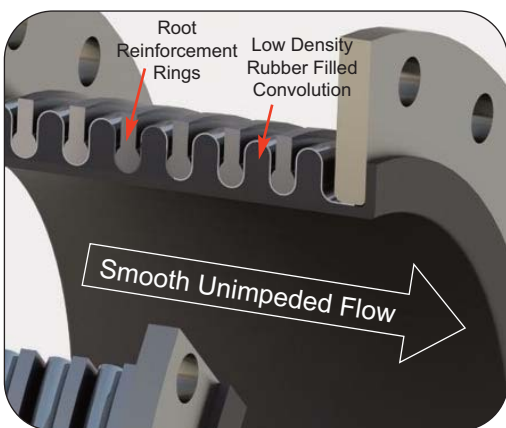

Low density rubber filled convolutions & root reinforcement rings

For ordering information, please contact Thorburn for details

Thorburn's Deep Sea & Underground Rubber Expansion Joints



Thorburn's Model 42HP-HDX being assembled, ready for external testing. Thorburn proprietary system was successfully tested in a pressure chamber to 225 psi (1550 kPa) external pressure.

Thorburn is the only manufacturer of rubber expansion joints in the world who has designed, built and tested its elastomeric expansion joints for external pressure up to 225 psi (1550 kPa), in sizes up to and including 28" (700 mm) diameter. This proprietary design was developed for one of the world's largest offshore oil rigs, Hibernia, situated off the coast of St. John's Newfoundland, Canada.

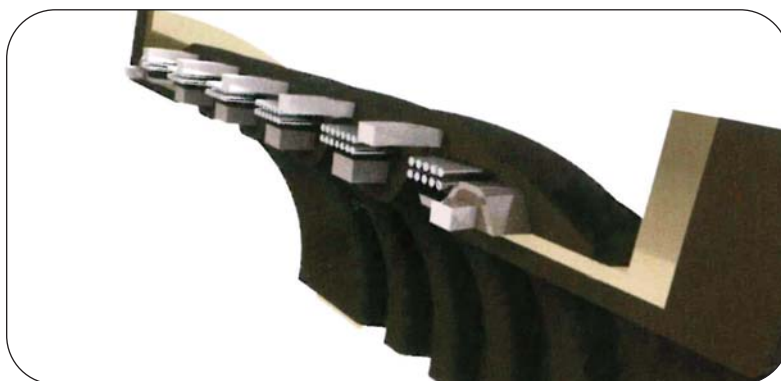

Hibernia offshore developmental project used Thorburn's flexible piping technology to provide external pressure containment, stress and movement absorption on its permanent ballast water containment piping system over 80 meters under the Atlantic Ocean, off the East coast of Newfoundland

Expansion Joints for Buried Piping Systems

Thorburn's 42HP-HDX rubber expansion joints are designed for underground installation piping systems. They absorb movements in angular and lateral deflection and provide solutions for piping systems subjected to earthquakes, temperature changes, ground settling and exterior impacts. They are used for raw water supply pipelines, water treatment plants and draining system piping systems.

Ordering information, please contact Thorburn for details

Thorburn's Metallic Protective Covers for Rubber Expansion Joints



Cover Materials:

- SA240 Type 304, 316, SS2205, SS2507
- Galvanized Carbon Steel made of SA516 Gr. 70, SA36
- Aluminum Sheet, ASME SB-209
- SB443 Type 625, SB424 Type 825, SB409 Type 800HT

Designed for GCC conditions, Thorburn's metallic covers protect rubber expansion joints from UV radiation, extreme heat, sandstorms, and mechanical damage.

Features

- Reduces UV cracking, thermal cycling damage, and ozone degradation.
- Protection against sand erosion
- Prevents accidental rupture due to mechanical impact, exposure to hot exhaust lines and chemical splash

Applications

- Ideal for outdoor installations
- Pump connections
- Desalination plants
- Refineries
- District cooling
- Potable water transmission lines
- HVAC industrial plants

THOR-SHIELD TLFP Spray Shields



Available with 150 psi (10 bar) & 300 psi (20 bar) rating

Thorburn Flex offers safety spray shields manufactured with a non-porous, 100% PTFE multi-directional TLFP material. THOR-SHIELD TLFP Spray Shields are manufactured with a non-porous, 100% PTFE multi-directional TLFP material and guarantee performance against harmful spray out and leakage regardless of severity and duration of chemical exposure.

Materials such as PTFE coated fiberglass, can be weakened by challenging industrial environments and often require monitoring. The translucent material used in the THOR-SHIELD TLFP Spray Shield allows safe and easy detection of moisture leakage at a flange. If leakage does occur at the flange, the spray shield can be cleaned and reused without concern for weakening due to chemical attack. THOR-SHIELD can be used in almost all industrial settings such as marine, offshore, pharmaceutical, chemical processing, FDA approved, cryogenic, and clean room applications.



Made from non-porous 100% PTFE multi-directional TLFP Material .

THOR-SHIELD TLFP Features

- Temperature range of -340°F (-207°C) to 600°F (316°C)
- pH range of 1-14
- Unaffected by exposure to wet, chemical environments & ultraviolet light
- Fire and tear resistant
- Drawstring is all-PTFE cord
- Custom sizes available
- Translucent material allows leak detection

THOR-SHIELD Optional Features



pH Indicating Patch

Sensitive pH Indicating Patch

Immediately signals a leak and will change color to red in the presence of acid or green in the presence of alkali. The pH indicating patch is also replaceable which allows continued use of the spray shield.



Clear PTFE Strip & Drain

Clear PTFE Strip & Drain

Clear PTFE strip in center allows for visual inspection of the expansion joint with a drain nipple attached to the bottom of the shield.

How to Order THOR-SHIELD for Flanges

(Thor-Shield) - (Pipe Size) - (Flange Type)

TS-20-FL3

Description:

Thor-Shield, Pipe Size DN32, Type PN10 Flanges.

How to Order THOR-SHIELD for Rubber Expansion Joints

(Thor-Shield) - (Joint Model) - (Pipe Size (in) X FF (in)) - (Flange Type)

TS-42HPW-24X20-FL3

Description:

Thor-Shield, Model 42HPW, Size 24" X 20" FF, Type PN10 Flanges.

(For metric put pipe DN size and length in mm example: TS-42HPW-DN600X500mm-FL3)

Description: Thor-Shield, Model 42HPW, Size DN600, Length 500mm, Type PN10 Flanges.

Ordering Codes

Pipe Sizes			Flange Type
Code	in	DN	
16	1	25	FL1 = ANSI B16.5, CI 150 FL2 = ANSI B16.5, CI 300 FL3 = PN10 FL4 = PN16 FL5 = PN25 FL6 = PN40
20	1 1/4	32	
24	1 1/2	40	
32	2	50	
40	2 1/2	65	
48	3	80	
64	4	100	
96	6	150	
128	8	200	
160	10	250	
192	12	300	
224	14	350	
256	16	400	
288	18	450	
320	20	500	
352	22	550	
384	24	600	

Rubber Expansion Joint Pre-Installation Checklist

A) Check requirements of the system. Double-check the performance limits of Thorburn's rubber expansion joints against the anticipated operating conditions.



Expansion joints should never be subjected to operating conditions beyond the temperature, pressure and/or vacuum recommendations of the manufacturer. If the total joint deflection caused by the initial installation and the movements of pipelines during system operation exceed

Thorburn's specifications or its general arrangement drawing (maximum allowable movement), then the pipeline should be altered to reduce the initial installation deflections.

B) Check the opening. Re-measure to ensure the face-to-face is accurate. Any variance from the specified opening will reduce the total allowable movements by the amount of variance.

Please note: Movement for Thorburn's rubber expansion joints are non-concurrent and the percentage of their sum cannot exceed 100%.

C) Align piping system. Thorburn's rubber expansion joints should never be used to compensate for misalignment unless such misalignment is a calculated basis of design. If the system cannot be aligned to within 1/8", an offset expansion joint should be used.

D) Check anchors, supports and alignment guides. To limit and control the pipe movements that Thorburn's expansion joints must absorb, the line should be anchored and properly supported. Paragraph 319.1 of ANSI B31.3 1980 states that: "Piping systems shall have sufficient flexibility to prevent thermal expansion or contraction of movements of piping supports and terminals from causing:

- a. Failure of piping or supports from overstress or fatigue;
- b. Leakage at joints; or,
- c. Detrimental stresses or distortion in piping or in connected equipment (pumps, turbines or valves, for example) resulting from excessive thrusts and movements in the piping."

Even if your particular piping system does not fall under the jurisdiction of the B31 piping codes, their guidelines are the industry standard for accepted good practice. In any case, Thorburn's rubber expansion joints and flexible pipe connectors are not designed to support the weight of the piping system. If the system is not properly supported or anchored to B31 piping codes, control rods must be installed. See pages 25 to 27 for additional information.

E) Check mating flanges. The mating flanges to be attached with the flanges of Thorburn's expansion joints or pipe connectors must be clean. Mating metal flanges should not have more than a 1/16" raised face. Used parts should be carefully examined for reasonable smoothness, and any adhering particles of old gaskets or other foreign material should be scraped off, taking care not to gouge or mutilate the flange surface.

F) Check expansion joint cover. Check the outside cover of the joint for damage before placing in service. The cover is designed to keep harmful materials from penetrating the carcass of the joint. If the cover is damaged and carcass is visible, it should be repaired before submitted into service.

G) Verify expansion joint location. It can be stated generally that the proper location of Thorburn's rubber expansion joints is close to a main anchoring point. Following the joint in the line, a pipe guide or guides should be installed to keep the pipe in line and prevent undue displacement of this line. This is the simplest application of a joint, namely, to absorb the expansion and contraction of a pipeline between fixed anchor points.

General Precautions Before Installation

Spare parts should be stored in a cool, dark, dry place in a flat position (Do not store on flange edges). Ideal storage is a warehouse with a relatively dry, cool location. Store flange face down on a pallet or wooden platform. Do not store other heavy items on top of a Thorburn expansion joint. Ten year shelf-life can be expected with ideal conditions. If storage must be outdoors, Thorburn's joints should be placed on wooden platforms and should not be in contact with the ground. Cover with a tarpaulin.

Large joint handling. Do not lift with ropes or bars through the bolt holes. If lifting through the bore, use padding or a saddle to distribute the weight. Make sure cables or forklift tines do not contact the rubber. Do not let Thorburn expansion joints sit vertically on the edges of the flanges for any period of time.

System tests should not exceed 150% of the rated working pressure of the expansion joints. Systems should not be operated above the rated pressure or temperature of the expansion joints.

Insulating over expansion joints is not recommended. If insulation is required, it should be designed for easy removal so the periodic inspection procedure can be maintained. This facilitates periodic inspection of the tightness of the joint bolting.

Welding should not take place in the vicinity of the expansion joints. If welding occurs frequently above the expansion joint, a protective shield shall be installed.

If underground installation is necessary, a protective shield over the expansion joint should be provided. Back-filling directly onto the expansion joints is not recommended.

Submerged in water. Contact Thorburn for specific recommendations.

Expansion Joint Installation Tips



Alignment: Pipelines containing standard expansion joints should be lined up accurately before installing the joints. If the joints are to be installed with appreciable initial misalignment, compression or elongation, the amount of these deflections should be deducted from the specified allowable movements of the joint. If the total joint deflection due to initial installation and the movement of the pipeline during system operation exceeds the published maximum allowable movement of the expansion joint, then the pipeline should be altered to reduce the initial installation deflections. Alternately the pipe may be anchored in some approved manner to limit the pipe movements to what the expansion joint can absorb.

Flange Face Lubricant: Apply in thin film of graphite dispersed in glycerin or water to the face of the rubber flanges before installing the expansion joint. This is a type of lubricant that may be used on rubber flanges. Its purpose is to simplify installation and to permit easy removal at some future date (not required for TFE or FEP lined joints).

Mating Flanges: Install the expansion joint against the mating pipe flanges and install bolts so that the bolt head and washer are against the retaining rings. If washers are not used, flange leakage can result – particularly at the split in the retaining rings. Flange-to-flange dimensions of the expansion joint must match the breech type.

Warning: The purpose of this publication is to provide a handy reference source of pertinent information for the thousands of engineers whose daily concern is designing piping systems and overseeing installations. No portion of this publication attempts to establish dictates in modern piping design. Thorburn makes no warranty concerning the information or any statement set forth in this publication, and both expressly disclaim any liability for incidental and consequential damages rising out of damage to equipment, injury to persons or products, or any harmful consequences resulting from the use of the information or reliance on any statement set forth in this publication.

Bolting: Insert bolt from the arch side of the flange. Tighten bolts by alternating around the flange and tighten all bolts equally. The bolts are not considered tight until the edge of the expansion joint flange bulges slightly. Check bolt tightness at least one week after going on stream and periodically thereafter. As any rubber-like material takes a set after a period of compression, the bolts may loosen and result in a break in the seal. It is particularly important to check bolts in a hot and cold water system before changing over from one medium to the other.

Tightening bolts: Tighten bolts in stages by alternating around the flange. If the joint has integral fabric and rubber flanges, the bolts should be tight enough to make the rubber flange O.D. bulge between the retaining rings and the mating flange. Torque bolts sufficiently to assure leak-free operation at hydrostatic test pressure. If the joint has metal flanges, tighten bolts only enough to achieve a seal and never tighten to the point that there is metal-to-metal contact between the joint flange and the mating flange.

Inspect cover for any accidental cuts or gouges: The protective cover should be repaired with rubber cement prior to system start-up.

Outdoor installation: If the expansion joint will be installed outdoors, make sure the cover material will withstand ozone, sunlight, etc. Materials such as neoprene and chlorobutyl are recommended. Materials painted with weather resistant paint will give additional ozone and sunlight protection.

Re-tighten bolts: Perform after seven days of operation and periodically thereafter. Rubber parts will take a set after a period of compression. Loosening of the bolts and breakage of the seal may occur if this procedure is not followed.

Special Precautions

Flangeless valves: Never install spool-type rubber expansion joints next to flangeless butterfly valves or flangeless check valves. Serious damage to the rubber joint can occur unless it is installed against full-face metal flanges.

Undue stress: Do not install an expansion joint in a system in an attempt to "pull" misaligned piping into position.

Retaining rings: Never install spool-type expansion joints without using the back-up retaining rings behind both flanges.

Control units: Install control units with a Thorburn rubber expansion joint if piping is not adequately anchored or if there is any question that movements may exceed the rated value of the joint.

A spare: At the time of installation, consider ordering a spare joint. Although Thorburn expansion joints are engineered to give long, dependable service, the cost of equipment downtime in the event a joint wears out can far outweigh the cost of a spare.

Control Rod Installation

Pre-installation checklist

a. Compare the requirements of the system to ensure the proper number of control rods have been specified (Minimum of two required).

b. Check units to be sure all parts are included. The unit consists of two control rod plates, one bolt with two nuts and two metal spherical washers or flat washers.

Control rod installation tips

c. Assemble Thorburn expansion joint between pipe flanges to the manufactured face to face length of the expansion joint. Include the retaining rings furnished with the expansion joint.

d. Assemble control rod plates behind mating pipe flanges. Flange bolts through the control rod plate must be longer to accommodate the plate. Control rod plates should be equally spaced around the flange. Depending upon the size and pressure rating of the system, 2, 3 or more control rods may be required.

e. Insert control rods through top plate holes. Steel washers are to be positioned at the outer plate surface. An optional rubber washer is positioned between the steel washer and the outer plate surface.

f. If a single nut per unit is furnished, position this nut so that there is a gap between the nut and the steel washer. This gap is equal to the joint's maximum extension (commencing with the nominal face to face length). To lock this nut in position, either "stake" the thread in two places or tack weld the nut to the rod. If two jam nuts are furnished for each unit, tighten the two nuts together, so as to achieve a "jamming" effect to prevent loosening. Consult Thorburn if there is any question as to the rated compression and elongation.

These two dimensions are critical in setting the nuts and sizing the compression pipe sleeves.

g. If there is a requirement for compression pipe sleeves, contact Thorburn to determine length to allow Thorburn joint to be compressed to its normal limit.

h. For Thorburn reducer joint installation, it is recommended that all control rod installations be parallel to the piping.

i. The expansion joint should always be installed in an accessible location to allow for future inspection or replacement.

Installation

j. Bolt the control rod plates to the opposite side of the metal flange at the same time the bolt is being installed through the rubber flange. The plates are to be equally spaced around the circumference of the flange.

k. Install the bolt through the third hole in each control rod plate after placing a metal flat washer or spherical washer set next to the bolt head.

l. Install the locking nuts after placing the flat or spherical washer half on the control thread, the first nut on the rod then the second.

m. Positioning control rod unit. The control rod assembly is set at the maximum allowable expansion and/or contraction of the joint.

n. Repeat steps **j.** to **m.** for each control rod unit.

Inspection Procedure For Expansion Joints In Service

The following suggestions are intended to determine if Thorburn's expansion joint should be replaced or repaired after extended service.

A. Replacement criteria: If an expansion joint is in a critical service condition and is five or more years old, consideration should be given to maintaining a spare or replacing the unit at a scheduled outage. If the service is not of a critical nature, observe the expansion joint on a regular basis and plan to replace after 10 years service. Applications vary and life can be as long as 30 years in some cases.

B. Procedures

1. Cracking, checking or crazing may not be serious if only the outer cover is involved and the fabric is not exposed. If necessary, repair on site with rubber cement where cracks are minor. Cracking where the fabric is exposed and torn

indicates the expansion joint should be replaced. Such cracking is usually the result of excessive extension, angular or lateral movements. Such cracking is identified by:

- a) a flattening of the arch;
- b) cracks at the base of the arch and/or
- c) cracks at the base of the flange.

To avoid future problems, replacement expansion joints should be ordered with Thorburn control rod units.

2. Some blisters or deformations, when on the external portions of Thorburn's expansion joints may not affect the proper performance of the expansion joints. These blisters or deformations are cosmetic in nature and do not require repair. If major blisters, deformations and/or ply separations exist in the tube, the expansion joint should be replaced as soon as possible. Ply separation at the flange O.D. can sometimes be observed and is not a cause for replacement of the expansion joint.

3. If the metal reinforcement of a Thorburn expansion joint is visible through the cover, the expansion joint should be replaced as soon as possible.

4. Any inspections should verify that the installation is correct; that there is no excessive misalignment between the flanges and that the installed face-to-face dimension is correct. Check for over-elongation, over-compression, lateral or angular misalignment. If incorrect installation has caused the expansion joint to fail, adjust the piping and order a new expansion joint to fit the existing installation.

5. If the joint feels soft or gummy, plan to replace the expansion joint as soon as possible.

6. If leakage or weeping is occurring from any surface of Thorburn's expansion joint, except where flanges meet, replace the joint immediately. If leakage occurs between the mating flange and the expansion joint flange, tighten all bolts. If this is not successful, turn off the system pressure, loosen all flange bolts and then re-tighten bolts in stages by alternating around the flange. Make sure there are washers under the bolt heads, particularly at the split in the retaining rings. Remove the expansion joint and inspect both rubber flanges and pipe mating flange faces for damage and surface condition. Repair or replace as required. Also, make sure the expansion joint is not over-elongated as this can tend to pull the joint flange away from the mating flange resulting in leakage. If leakage persists, consult the manufacturer for additional recommendations.

Thorburn 60RPC Flanged Pump Connector

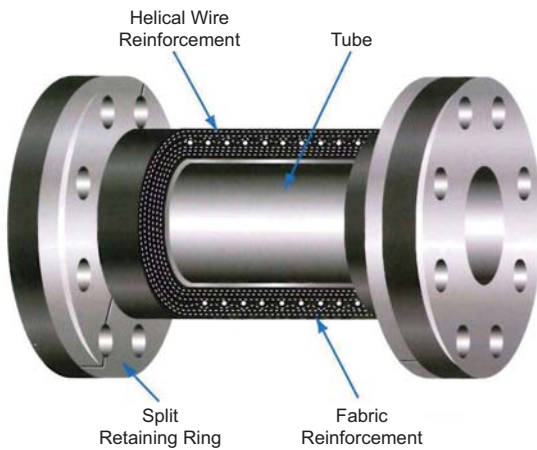

Cross section of Thorburn flanged 60RPC pump connector

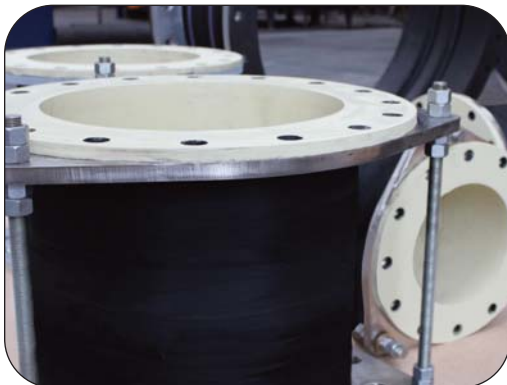

Thorburn Model 60RPC flanged pump connector with control rod assembly Type "CR"



Thorburn Model 60RPCX swivel flanged pump connector with acoustical control cables Model TACC

Ultra Quiet Sound Absorbing System

Thorburn's 60RPC is an ultra quiet sound absorbing integral flanged pipe connector. The flange is drilled to conform to the bolt pattern of the companion metal flanges of the pipeline. Thorburn's 60RPC is manufactured from high quality elastomers to safely satisfy your chemical abrasion-sound requirements. Specify Thorburn's 60RPC and you are assured of the highest quality leak tight sound and movement absorbing pump connector system in the world.

Advantages

Absorbs pipe wall and fluid-borne noise

The low sound transmission properties of rubber allow for pipe wall sounds to be absorbed by Thorburn's 60RPC connector by the volumetric expansion (breathing of Thorburn's 60RPC connector). In other words, sound weakens travelling through rubber. Thorburn's 60RPC length influences sound absorption.

Isolates vibration and motion

Vibration originating from mechanical equipment is absorbed by Thorburn's 60RPC connectors. As most machinery vibrates in a radial direction from the main shaft, Thorburn's 60RPC should be installed horizontally and parallel to this main shaft. Thorburn's 60RPC will tolerate minimal axial motion. But for two-plane vibration/motion, it is recommended to use two flexible rubber connectors installed at right angles, one to absorb the horizontal vibration and one the vertical vibration. A tension anchor is usually needed to stabilize the elbow between the connectors.

Piping system misalignment compensation

Installation in a rigid piping system is facilitated and Thorburn's 60RPC connectors add a flexible component that is automatically self correcting for misalignment created by structural movements caused by thermal expansion or ground shifts. See page 40 for product specification details.

Reduce system stress and strain

Rigid attachment of piping to critical or mechanical equipment can produce excessive loading. Thermal or mechanically created strains-stress-shock are cushioned and absorbed with the installation of Thorburn 60RPC.

Full flow with less turbulence or material entrapment

Thorburn's 60RPC connectors' smooth rubber lining allows full flow without turbulence. Metallic connectors depend upon bellows or convolutions to absorb motion. These bellows/convolutions can create flow turbulence and also create an area for material entrapment or bacteria growth.

WARNING: Control unit cable or rod assembly usage: Thorburn control units are designed to protect Thorburn 60RPC connector from excessive elongation. Control rods are always recommended as a protection against: 1) thermal shrinkage in the piping, 2) hydrostatic tests at elevated pressures and 3) line pressure surges. Thorburn control rods must be used: 1) when the piping containing the rubber connector is not anchored and 2) when the rubber connector is attached to unsupported pipe or equipment.

Nominal Pipe Size (ID)	"F" Neutral Length Face-To-Face	Movement Capability From Neutral			Weight (lbs) (Connector Only)	Weight (lbs) Retaining Ring Set
		Axial Comp/Ext (in)	Lat. Def. (+/- in)	Angular Def. (deg)		
3/4	12	0.158	1.97	21.8	2.4	1.5
	18	0.236	2.96	31.0	3.2	
1	12	0.158	1.77	17.7	3.3	1.9
	18	0.236	2.66	25.6	4.2	
1 1/4	12	0.158	1.58	14.0	4.0	2.4
	18	0.236	2.36	20.6	5.0	
	24	0.315	3.15	26.6	6.0	
1 1/2	12	0.158	1.39	11.3	4.3	2.6
	18	0.236	2.09	16.7	5.4	
	24	0.315	2.78	21.8	6.5	
2	12	0.158	1.18	9.1	5.6	3.6
	18	0.236	1.77	13.5	6.8	
	24	0.315	2.36	17.7	8.0	
	30	0.354	2.96	19.8	9.2	
2 1/2	12	0.158	0.98	7.0	6.9	5.3
	18	0.236	1.48	10.5	8.2	
	24	0.315	1.97	13.8	9.5	
	30	0.354	2.46	15.5	10.0	
	36	0.423	3.15	18.0	11.5	
3	18	0.236	1.18	8.5	10.6	5.6
	24	0.315	1.58	11.3	11.7	
	30	0.354	1.97	12.7	14.6	
3 1/2	18	0.236	0.89	7.6	12.2	6.5
	24	0.315	1.18	10.1	14.7	
	30	0.354	1.48	11.3	17.2	
4	18	0.236	0.89	6.8	14.5	7.3
	24	0.315	1.18	9.1	17.4	
	30	0.354	1.48	10.2	19.7	
5	24	0.315	0.89	7.3	20.1	7.9
	30	0.354	1.12	8.2	23.1	
6	24	0.315	0.89	6.1	24.1	9.1
	30	0.354	1.12	6.8	27.2	
8	24	0.236	0.71	3.4	35.7	14.0
	30	0.276	0.89	4.0	40.2	
	48	0.472	1.42	6.8	59.4	
10	24	0.236	0.63	2.7	48.7	17.0
	30	0.276	0.79	3.2	59.0	
	48	0.472	1.26	5.5	92.0	
12	24	0.236	0.47	2.3	66.5	24.1
	30	0.276	0.59	2.7	81.0	
	48	0.472	0.95	4.2	126.0	
14	24	0.236	0.47	2.0	108.0	26.8
	30	0.276	0.59	2.3	133.0	
16	24	0.236	0.47	1.7	153.0	32.1
	48	0.472	0.95	3.4	294.0	
18	24	0.236	0.24	1.5	205.0	30.6
	48	0.472	0.48	3.1	394.0	
20	24	0.236	0.24	1.4	270.0	35.9
	48	0.472	0.48	2.7	519.0	

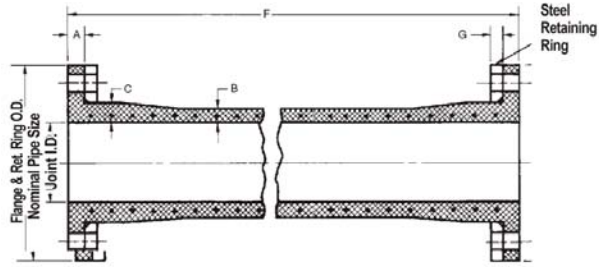

Thorburn Part Number*	Nominal Pipe Size (ID)	125/150# Flange Dim. Pipe - Rings - Rods			Pipe Dimensions		Operating Pressure Positive PSIG	
		Flange OD	Bolt Circle	# Holes Hole Size	"A" Flange Thickness	"B" Body Thickness	Style SP	Style HP
60RPC(X)-12	3/4	3.88	2.75	4 - 0.625	0.591	0.472	150	300
60RPC(X)-16	1	4.25	3.12	4 - 0.625	0.591	0.551	150	300
60RPC(X)-20	1 1/4	4.62	3.50	4 - 0.625	0.591	0.551	150	300
60RPC(X)-24	1 1/2	5.00	3.88	4 - 0.625	0.591	0.551	150	300
60RPC(X)-32	2	6.00	4.75	4 - 0.750	0.591	0.551	150	250
60RPC(X)-40	2 1/2	7.00	5.50	4 - 0.750	0.591	0.591	150	250
60RPC(X)-48	3	7.50	6.00	4 - 0.750	0.591	0.591	150	250
60RPC(X)-56	3 1/2	8.50	7.00	8 - 0.750	0.591	0.669	150	250
60RPC(X)-64	4	9.00	7.50	8 - 0.750	0.591	0.669	150	250
60RPC(X)-80	5	10.00	8.50	8 - 0.875	0.591	0.669	150	250
60RPC(X)-96	6	11.00	9.50	8 - 0.875	0.591	0.709	150	250
60RPC(X)-128	8	13.50	11.75	8 - 0.875	0.591	0.787	150	250
60RPC(X)-160	10	16.00	14.25	12 - 1.0	0.787	0.866	150	250
60RPC(X)-192	12	19.00	17.00	12 - 1.0	0.787	0.984	150	250
60RPC(X)-224	14	21.00	18.75	12 - 1.125	0.787	0.984	125	200
60RPC(X)-256	16	23.50	21.25	16 - 1.125	0.787	0.984	100	150
60RPC(X)-288	18	25.00	22.75	16 - 1.250	0.875	1.0	100	150
60RPC(X)-320	20	27.50	25.00	20 - 1.250	1.0	1.0	100	150

- * Notes:
- When ordering use Model 60RPCX for swivel flange applications or 60RPC for fixed flange applications
 - Dimensions shown meet 125/150# standards of: ANSI B-16.1, B-16.24, B-16.5; AWWA C-207 Table 1 and 2, Class D; MSS SP-44 and NBS/PS 15-69.
 - Other flange drilling and dimensions available upon request.
 - Vacuum rating is 30" hg. in all cases. Pressure rating is based on 180°F operating temperature. For higher temperatures pressure might be reduced. Contact Thorburn.

How to Order

60RPC160-24-SP-D-C-R

Description:
Fixed Flange - 10" Pipe - Standard Pressure - Nitrile Tube - Neoprene Cover - Retaining Rings

Ordering Codes:
 X = Swivel Flange CR = Control Rods
 SP = Standard Pressure CC = Control Cables
 HP = High Pressure

* Notes:
 1. For optimum noise and vibration absorption, use this or longer length
 2. The degree of angular movement is based on the maximum rated extension
 3. Larger I.D. or length sizes available

660/760 PC Ultra-Quiet Small Diameter Coupled Pipe Connectors



Thorburn's 760-PC Pump Connector with male fitting to end joints

Ultra Quiet Sound Absorbing Connector System

Thorburn's 660PC (150 psi) and 760PC (300 psi) rubber pipe connectors are designed for smaller diameter pipelines and come with factory attached couplings and are usually supplied with male/male couplings but are also available with male/female fittings. Thorburn's 660PC/760PC are specifically designed to eliminate vibration between pump and pipeline either for suction or discharge service.



Thorburn's 660-PC Pump Connector with female fitting to end joints

Standard Dimensions For Vibration

Thorburn Model	Pipe Size		Standard Overall Length	
	ID (in)	Code	(in)	Code
660/760PC(T)-12	3/4	12	12	012
660/760PC(T)-16	1	16	18	018
660/760PC(T)-20	1 1/4	20	18	018
660/760PC(T)-24	1 1/2	24	18	018
660/760PC(T)-32	2	32	24	024
660/760PC(T)-40	2 1/2	40	24	024
660/760PC(T)-48	3	48	36	036
660/760PC(T)-64	4	64	36	036

Specifications

Model	Working Pressure		Maximum Water Service Temperature	
	psi	bar	180°F	82°C
660PC	150 psi	10 bar	180°F	82°C
660PCT	150 psi	10 bar	250°F	121°C
760PC	300 psi	20 bar	180°F	82°C
760PCT	300 psi	20 bar	250°F	121°C

How to Order

760PCT-24-D-C-MPS6-MPS6-018

Description:

250psi Pipe Connector - 24" ID - Nitrile Tube - Neoprene Cover male NPT 316SS First End - Male NPT 316SS Second End - 18 inches in Length

End Codes:

MP = Male NPT
 FP = Female NPT
 SF = Sanitary Flange
 XX = Specify

End Material Codes:

A = Aluminum
 C = A108/A105
 Plated Carbon Steel
 S6 = 316SS
 X = Specify

Tube & Cover Material Codes:

A = Natural rubber
 B = Pure gum
 C = Neoprene
 D = Nitrile
 E = Butyl
 F = Hypalon
 G = Cross/Link
 Polyethylene
 H = EPDM
 I = Viton
 J = Teflon PTFE to 14" > 16" FEP Lined
 K = PFA
 L = Silicone
 M = Nitril NSF-61
 Certified tube only for potable water service
 N = HNBR
 X = Special

28TW Paper Mill Extra Flex Suction Hose



Thorburn's 28TW is sometimes referred to as a "Suction Box" or as a "Suction Couch" hose on a paper machine

Application

Thorburn's 28TW is a custom designed material handling hose that supports full vacuum suction with incredible minimum bend radius capabilities. Thorburn's 28TW will accept a high degree of lateral flexing as well as contraction due to end thrust. The 28TW is an ideal flexible component for services that require the suction box on paper machine to be raised or lowered.

Construction

Tube: Corrugated black synthetic rubber.

Reinforcement: Polyester fiber wire. Reinforced for full vacuum.

Cover: Black synthetic corrugated rubber.

Specifications

Thorburn Part Number	Hose ID	Hose OD	Min. Bend Radius	Approx. Weight
	inch	inch	inch	lbs/100ft
28TW32	2	2 11/16	4	283
28TW38	2 3/8	3 1/16	5	320
28TW46	2 7/8	3 9/16	6	355
28TW48	3	3 3/4	6	367
28TW56	3 1/2	4 1/4	7	408
28TW64	4	4 5/8	8	441
28TW66	4 1/8	4 3/4	8	462
28TW68	4 1/4	4 7/8	9	479
28TW72	4 1/2	5 1/8	9	506
28TW80	5	5 5/8	10	547
28TW84	5 1/4	6 1/8	11	585
28TW89	5 9/16	6 3/16	11	589
28TW96	6	6 5/8	12	622
28TW100	6 1/4	7 1/8	13	662
28TW106	6 5/8	7 1/4	13	665
28TW128	8	8 5/8	16	793
28TW132	8 1/4	8 7/8	17	818
28TW136	8 1/2	9 1/8	17	832
28TW138	8 5/8	9 1/4	17	840
28TW140	8 3/4	9 3/4	18	886
28TW160	10	10 5/8	20	957
28TW164	10 1/4	10 7/8	20	979
28TW168	10 1/2	11 1/2	21	1009
28TW172	10 3/4	11 3/8	21	1019
28TW192	12	12 5/8	24	1119
28TW224	14	15	28	1729
28TW256	16	17	32	1902



Irving Pulp And Paper Mill is situated on the St. John River at Reversing Falls uses Thorburn's flexible piping



Thorburn's Model 28TW is used on the suction box where tight minimum bend radius and extra flexibility is required

Ordering information see page 82

60TMH Wire Reinforced / 61TMH Non-Wire Reinforced Flexpipe



Available with smooth tube & cover to provide smooth flow with bend radius of 4X ID



Available with corrugated tube & cover with integral annular rings to increase flexibility to 2X ID



Available with factory assembled permanently attached crimped ends

Thorburn's 60TMH/61TMH Flexpipe is custom designed for use in piping systems that require isolation and absorption of severe noise, vibration, misalignment, lateral deflection and movements caused by mechanical or temperature changes. The 60TMH/61TMH Flexpipe system replaces metal piping and is optimal for pipelines requiring resistance to electrolysis, corrosion, abrasion and water hammering.

Construction

TUBE: Available with various tube compounds wall thickness with smooth or corrugated construction as determined by the application and the media. *Please call Thorburn for details.*

REINFORCEMENT: Multiple layers of precisely angled cross woven calendared fabric. The 60TMH/61TMH has integrally built in evenly spaced heavy duty helix spring wire or annular rings that withstand the rated working pressures from full vacuum to 1000 psi (70 bar). Can be designed to support a minimum bend radius from two times the diameter or maintain unsupported rigidity over long lengths. The 61TMH can be rolled up for easy handling and storage. *Please call Thorburn for details.*

COVER: Available with various cover compounds and wall thicknesses with smooth or corrugated construction as determined by the application and the media. *Please call Thorburn for details.*

SIZES: 1/2" (12mm) to 48" (1200mm) I.D. up to 100ft (30m) long. *Longer lengths available on special order only.*

SPECIAL NOTES:

1. Thorburn's 60TMH/61TMH assemblies are custom designed for specific applications, therefore the construction may vary depending on pressure, bend radius requirements & media.
2. The standard bend radius for 60/61TMH is typically 6X ID (61TMH bend radius N/A).
3. Corrugating the 60TMH cover and tube will improve the bend radius at lower pressures.
4. Incorporating annular rings with a smooth tube and cover will improve the bend radius at high pressures.
5. The forces required to make a 60/61TMH bend have a direct relation to the pressure.
6. Arches can be added to the 60/61TMH to provide axial movement.
7. Special end configuration (other than shown) are available upon request.

For ordering information, please see pages 60 & 61 for details

Field Attachable Fitting-to-End Joints for 60TMH/61TMH Rubber Hoses



60TMH Split Cast Coupling Hose Assembly

Thorburn's field attachable fitting to end joints are a ready made hose assembly solution designed to accommodate urgent site custom length hose assembly requirements. The hose lengths are designed to be cut to length on site and fitted with Thorburn's aluminum split cast coupling to provide a readymade site assembled flanged hose.

Thorburn's field attachable split cast couplings are not in contact with the process flow. The hose length can be cut to suit the intended duty, ready for installation. In addition, it allows the re-use of the split cast couplings as the fittings are not in contact with the process flow.

Thorburn's field attachable fitting-to-end joints are an economical solution for quick emergency change out. Thorburn's reusable multi-drill pattern coupling system enables operators to minimize inventory costs by stocking bulk hose with separate Thorburn clamped ends instead of factory fabricated hose assemblies.

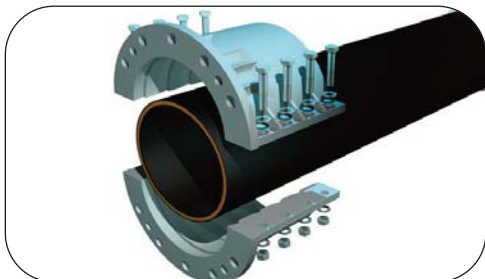

Thorburn FAS150 Smooth Cover Coupling

Advantages

- High tensile reinforcement cord with a steel wire helix
- An abrasion and UV resistant smooth or corrugated elastomeric compound outer cover
- Suitable working temperature between -40°C and 82°C
- Minimum bend radius of 6 X ID.
- Safety factor is four times the working pressure

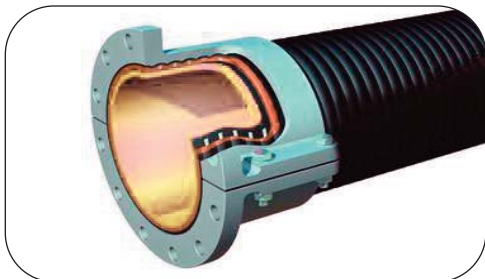

Thorburn FAS150 Corrugated Cover Coupling

Typical Applications

- Mineral processing plants
- Sand and gravel industries
- Cement and coal industries
- Pump stations

How to Order 60TMH/61TMH Assembly With Field Attachable Fitting-to-End Joint

Part Number Example & Description (See Ordering Codes - Page 60)

(Part number must follow the order listed below. Suffix "X" to specify special construction options)

60TMH-96-B-C-04-02-150-RDF-YY-120

(Part number in imperial units. ID is always in 1/16 " example: 64=4", 48=3", 128=8")

60TMH	Flexpipe Model 60TMH
96	Inside Diameter (6 Inches)
B	(Code B) Pure Gum
C	(Code C) Neoprene
04	(Code 04) Tube Thickness - 1/4 Inches
02	(Code 02) Cover Thickness - 1/8 Inches
150	(Code 150) Working Pressure - 150 psi
FAS150	(Code FAS150) Smooth Cover 150lbs split Cast Coupling End
FAS150	(Code FAS150) Smooth Cover 150lbs split Cast Coupling End
120	Overall Length - 120 Inches (specify mm for metric length)



60TMH/61TMH Ordering Codes

Insert Suffix "X" at the end of the part number to specify special construction options such as corrugated tube, corrugated cover & annular rings to meet specific design requirements

Tube & Cover Compounds

Our Flexpipe hoses are manufactured to the latest RMA standards.

Code A	Black natural rubber up to 180°F (82°C).
Code B	Pure gum up to 180°F (82°C).
Code C	Neoprene up to 212°F (100°C).
Code D	Nitrile up to 225°F (107°C).
Code E	H ₃ (Butyl) up to 300°F (148°C).
Code F	Hypalon up to 250°F (121°C).
Code G	Cross linked polyethylene up to 150°F (65°C).
Code H	EPDM up to 300°F (148°C).
Code I	Viton up to 350°F (176°C).
Code J	PTFE Lined up to 400°F (204°C).
Code K	PFA Lined up to 400°F (204°C).
Code L	Silicone up to 500°F (260°C).
Code M	HNBR up to 300°F (148°C).
Code N	Nitrile NSF-61 Certified tube (Only for potable water service).
Code O	Ceramic Lined up to 400°F (204°C).
Code P	UHMW-PE up to 275°F (135°C)
Code X	Specify.



Custom hose building capabilities: 12mm to 1200mm
Lengths: Up to 30m
Design Pressures: Full vacuum up to 70 bar

Tube & Cover Thickness

Code 01	1/16" (1.5mm)
Code 02	1/8" (3mm)
Code 04	1/4" (6mm)
Code 06	3/8" (10mm)
Code 08	1/2" (13mm)

Note: PTFE lining is typically less than 1/8" (3mm)

Working Pressure Codes

Code 25	25 psi (2 bar)
Code 75	75 psi (5 bar)
Code 100	100 psi (7 bar)
Code 150	150 psi (10 bar)
Code 250	250 psi (17 bar)
Code 500	500 psi (34 bar)
Code 1000	1000 psi (69 bar)

Note: Minimum burst pressure is 4X working pressure

Pipe Fittings

Code E90	90° Elbow (Standard)
Code E90L	90° Elbow (Long)
Code E45	45° Elbow
Code Y	"Y" Connector
Code T	Tee Connector
Code C	Cross Connector
Code L	Lateral Connector
Code RC	Concentric Reducer
Code EC	Eccentric Reducer
Code X	Custom Connector (Specify)

Pipe Fitting Ends

Code RDF	Rubber Duck Flange with Split Rings
Code IFE	Integral Flange End

Flexpipe Hose Ends

Code PE	Plain End
Code SE	Soft End
Code ITN	Integral Rubber Tapered Nozzle End
Code EE	Enlarged End
Code WTE	Wire To End
Code BE**	Beaded Ends with Split Flange
*Code SWF150**	Swivel Flange 150lbs
*Code SWF300**	Swivel Flange 300lbs
Code RDF	Rubber Duck Flange with Split Rings
Code IFE	Integral Flange End
*Code BIN**	Built In Nipple Threaded
*Code BINF150**	Built In Nipple with Flange 150lbs drill size
*Code BINF300**	Built In Nipple with Flange 300lbs drill size
*Code BINFV**	Built In Victaulic Nipple
Code NLS150	Built In Nipple Rubber Lined Flange 150lb
Code NLS300	Built In Nipple Rubber Lined Flange 300lb
Code XX	Specify Special Type First End
Code YY	Specify Special Type Second End

* Add Suffix "C" at end of code for Crimped or Swaged End

** Standard material is plated carbon steel, add suffix "S6" for 316SS

Field Attachable Fitting-to-End Joints

Code FAS150	Smooth Cover Split Cast Coupling 150lbs
Code FAS300	Smooth Cover Split Cast Coupling 300lbs
Code FAC150	Corrugated Cover Split Cast Coupling 150lbs
Code FAC300	Corrugated Cover Split Cast Coupling 300lbs

Typical 60TMH/61TMH Ends

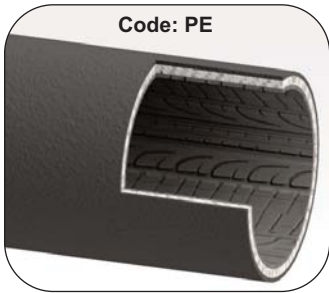

Code: PE

Capped End

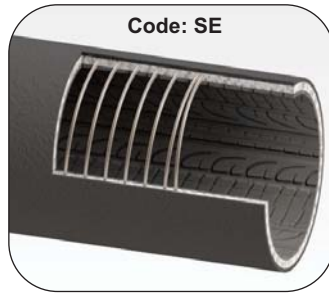

Code: SE

Soft End

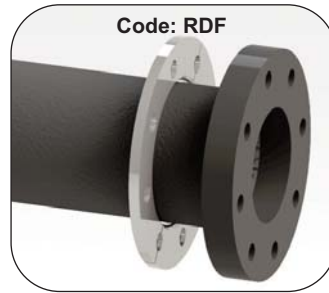

Code: RDF

Rubber & Duck Flanges

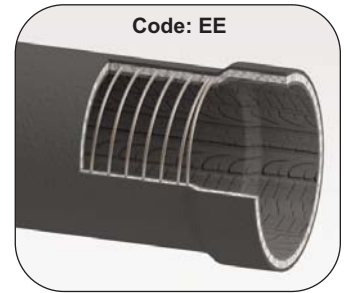

Code: EE

Enlarged End



Code: WTE

Wire To End

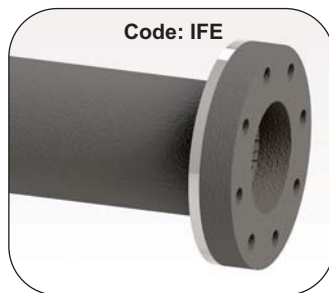

Code: IFE

Integral Flange End

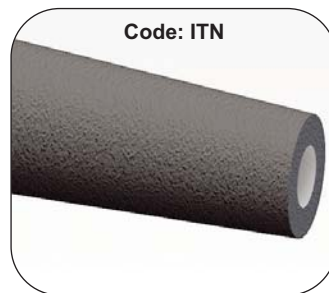

Code: ITN

Integral Tapered Nozzle Ends

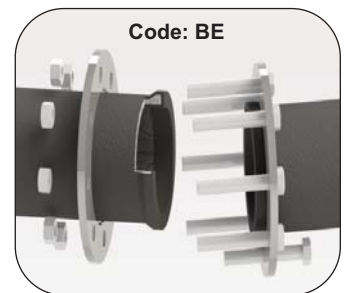

Code: BE

Beaded Ends With Split Flanges

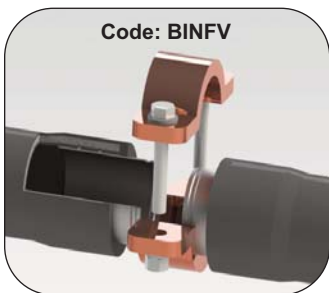

Code: BINFV

Built-In Victaulic Nipple



Code: NLS

Built-In Nipple Rubber Lined
Flanged 150lbs & 300lbs

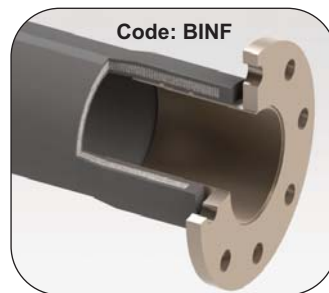

Code: BINF

Built-In Nipple Flanged
150lbs & 300lbs

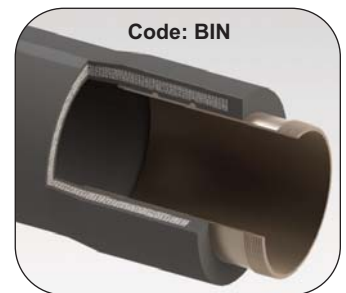

Code: BIN

Built-In Nipple Threaded

How to Order 60TMH/61TMH Hose Assemblies

Part Number Example & Description (See Ordering Codes - Page 60)

(Part number must follow the order listed below. Suffix "X" to specify special construction options)

60TMH-96-I-H-04-02-150-RDF-BE-120

(Part number in imperial units. ID is always in 1/16 " example: 64=4", 48=3", 128=8")

60TMH	Flexpipe Model 60TMH
96	Inside Diameter (Inches)
I	(Code I) Compound Tube Material - Viton
H	(Code H) Compound Cover Material - EPDM
04	(Code 04) Tube Thickness - 1/4 Inches
02	(Code 02) Cover Thickness - 1/8 Inches
150	(Code 150) Working Pressure - 150 psi
RDF	(Code RDF) Rubber Duck Flange End
BE	(Code BE) Beaded End - Split Flange End
120	Overall Length - 120 Inches (specify mm for metric length)



60TMH/61TMH Rubber Pipe Fittings



60TMH-E90 Rubber 90° Elbow Fitting



60TMH-T Tee Rubber Fitting

Thorburn's 60TMH/61TMH rubber pipe fittings are designed to replace metal pipe fittings reducing stress and strain on equipment and piping systems. Thorburn's 60TMH/61TMH rubber pipe fittings will reduce the effects of seismic & ground settling movements, noise vibration from pumps, compressors, and other equipment. Thorburn's 60TMH rubber pipe fittings are custom designed and manufactured from various rubber compounds and reinforced to withstand full vacuum and pressures up to 300psi. Typical end configurations are integral flat face rubber flanges drilled to ANSI class 150 & 300 (other standard flange drillings are available)

Advantages

- Reduces noise and vibration
- Protects pump casing
- Relieves pipe stress and strain
- Excellent for seismic & ground settling movements

Construction

TUBE: Available with various tube compounds wall thicknesses to maximize service life and is determined by the application and the media.

REINFORCEMENT: Multiple layers of precisely angled cross woven fabric with calendared polyester or fiberglass fabric. Integrally built with an evenly spaced heavy duty helix spring wire that withstands full rated working pressures from full vacuum to 300 psi. *Please call Thorburn for details.*

COVER: Available with various cover compounds and wall thicknesses to maximize service life and is determined by the application.

SIZES: 1/2" to 24" I.D. Larger sizes available on special order only.

60TMH/61TMH Pipe Fitting Styles (Built-in offsets available)



How to Order 60TMH Pipe Fittings

Part Number Example & Description (See Ordering Codes - Page60)

60TMH-RC-10X10-D-C-04-02-150-RDF-RDF

(Part number in imperial units)

60TMH-RC	Flexpipe Model 60TMH Concentric Reducer
10X8	Inside Diameter (Inches)
D	Compound Tube Material - Nitrile
C	Compound Cover Material - Neoprene
04	Tube Thickness (Inches)
02	Cover Thickness (Inches)
150	Code 150 (Working Pressure)
RDF	Rubber Duck Flange End
RDF	Rubber Duck Flange End

(List additional ends for Tee, Cross & Lateral fittings)



Thorburn Series - DJ Rubber Dismantling Joints



Thorburn Series - DJ rubber dismantling joints facilitate the installation or removal of pipeline equipment and absorbs thermal movement, vibration and ground settling

Thorburn rubber dismantling joints simplify the installation and removal of isolation valves, control valves, check valves, non-return valves, flow metering valves, pump sets, pressure reducing valves, flanged pipe spools and fittings.

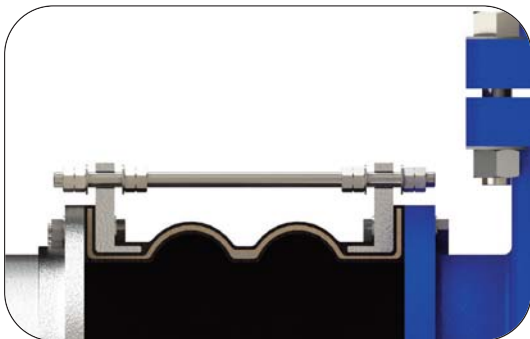

Thorburn Series 62HPWXX-DJ rubber dismantling joint installed between the pipeline and equipment

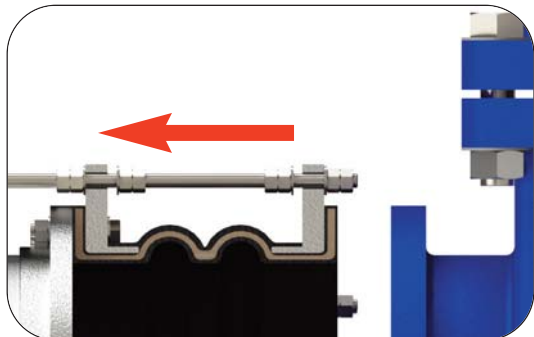

Thorburn Series 62HPWXX-DJ rubber dismantling joint axially compressed to facilitate installation or removal of equipment

Thorburn Series-DJ Rubber Dismantling Joints Facilitates installation or removal of pipeline equipment

Thorburn Series DJ rubber dismantling expansion joints play an essential role in the design and layout of piping systems. Primarily they compensate for gaps between the pipe sections and equipment with its built-in movement mechanisms and facilitate the removal of equipment in the pipeline for maintenance or replacement. Unlike metallic telescopic dismantling joints Thorburn Series DJ rubber dismantling joints can also accommodate lateral misalignment in piping systems as well as compensate for thermal movement, vibration and ground settling on the pipeline equipment.

Applications

- Cooling water systems
- Water treatment plants
- Seawater and desalination plants
- Crude and refined oil
- Air, gas and steam
- Flue gas cleaning plants
- Granular powder
- Industrial pipelines
- Pumping stations
- Sewage treatment plants
- Plant constructions
- Condensers



Thorburn rubber dismantling joints installed in an FRP piping system

Thorburn Rubber Dismantling Joint Features and Benefits

- Standard or custom face-to-face dimensions**
 Available with multiple arch designs to accommodate large amounts of axial gaps in a piping system
- Built-in nub**
 Facilitates axial extension and compression to install or remove equipment such as pumps and valves in a piping system
- Built-in solid metallic integral gusset and retaining rings (dismantling ring)**
 Provides compressive load sealing and axial compression and extension to permit equipment installation or removal
- Built-in L-shaped reinforcement rings**
 Suitable for extremely high pressure applications
- Filled arch Option**
 To eliminate sediment build-up and provide smooth flow
- UV protective coatings**
 To protect the rubber dismantling joint from ozone radiation in the most extreme desert conditions
- Wide variety of materials**
 Elastomers - (EPDM, FKM HNBR, Butyle, neoprene, PTFE/FEP lined)
 Restraint Hardware Metals - (SS316, Super Duplex, Inconel 625, Hasteloy C276)
 to accommodate a variety of environmental and design conditions including extreme abrasion, chemical and saltwater corrosion
- Available in other Thorburn rubber expansion joint models to suit specific application requirements**
 Thorburn Model 15RA - For very low pressure applications (Page 23)
 Thorburn Model 42HPW - For medium pressure applications (Page 16)
 Thorburn Model 42HP-CR - Concentric reducer (Page 14-15)
 Thorburn Model 42HP-ER - Eccentric reducer (Page 14-15)
- Optional Thor-Shield cover**
 100% PTFE multi-directional TLFP material cover for extreme chemical and corrosive environments. Thor-Shield also protects against sprayout of connecting flanges (Page 34)

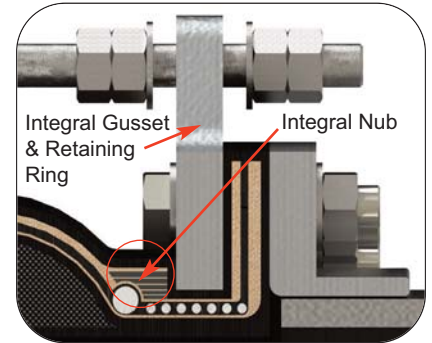

Thorburn Series 62HP-DJ for low to medium pressure applications

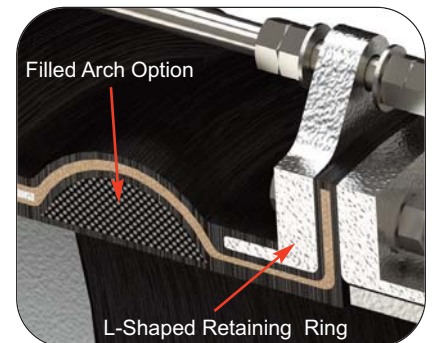

Thorburn Series 62HPWXX-DJ for high pressure applications

Thorburn Rubber Dismantling Joint Components

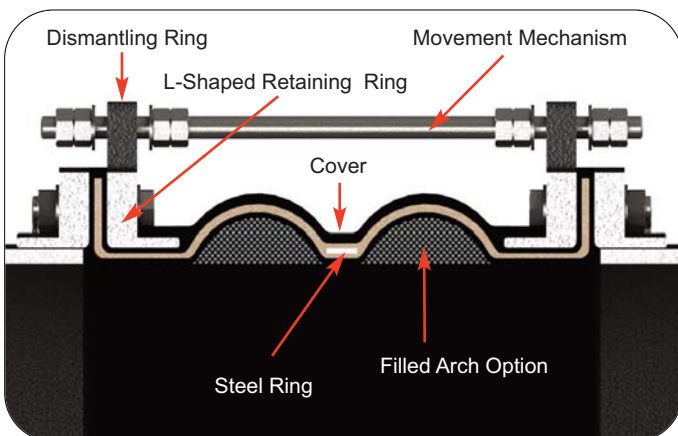

Thorburn Series 62HPWXX-DJ high pressure rubber dismantling expansion joint

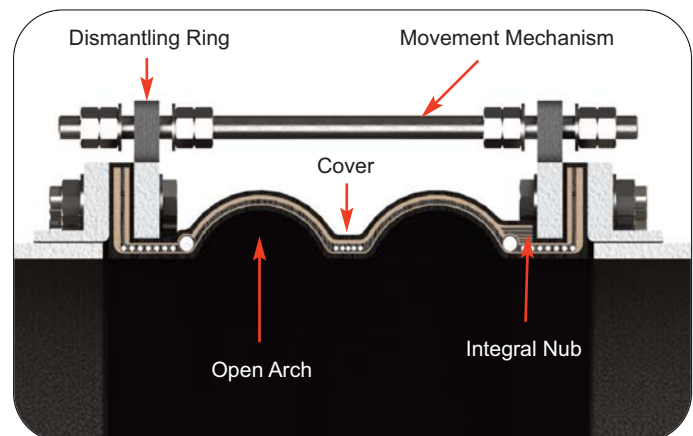

Thorburn Series 62HP-DJ low to medium pressure rubber dismantling expansion joint

Thorburn Rubber Dismantling Joint Specifications

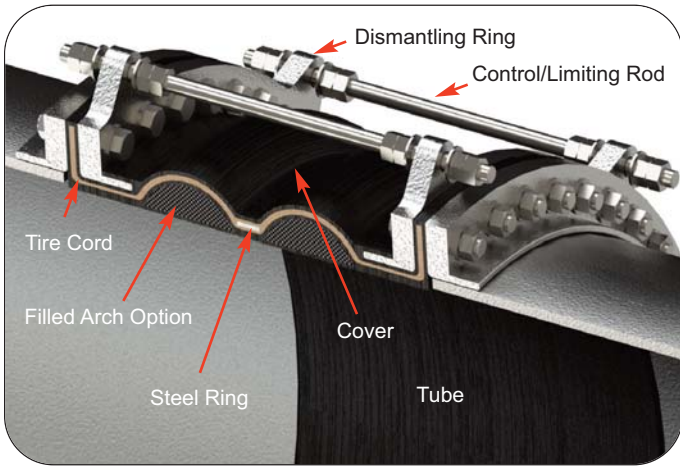

Thorburn Series 62HPWXX-DJ high pressure rubber dismantling expansion joint

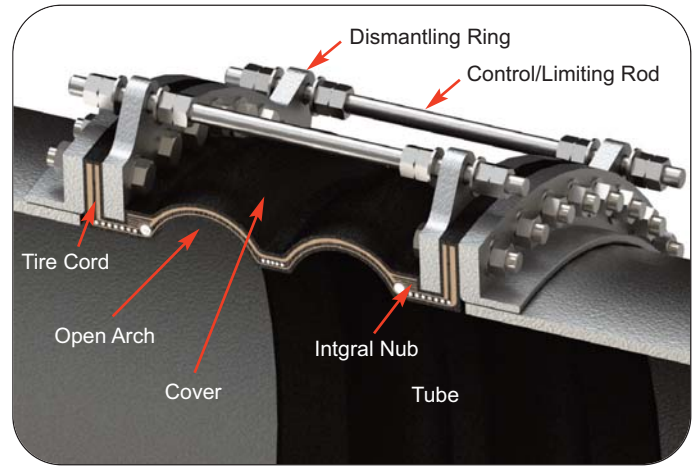

Thorburn Series 62HP-DJ low to medium pressure rubber dismantling expansion joint



Thorburn Series 62HP-DJ rubber dismantling joints ready for shipment

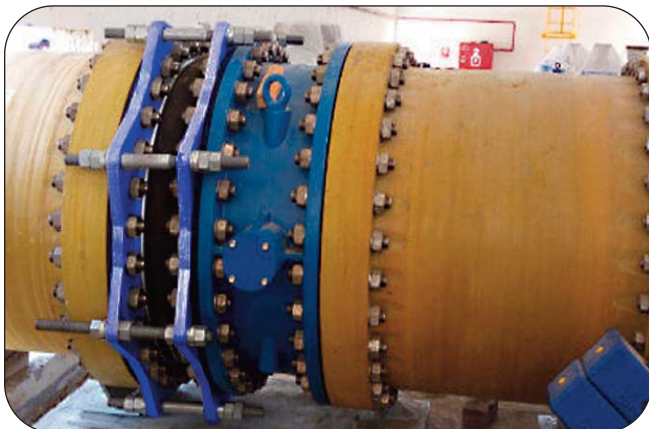

Thorburn Series 62HPWXX-DJ rubber dismantling joint installed in an FRP piping system

Construction

Rubber Expansion Joint

Thorburn Expansion Joint Models:

- 62HP (See Page 17)
- 62HPWXX (See Page 15)

Sizes: 80mm to 5,000mm (3"-200") - Custom diameters possible

Length: (Standard) 150mm to 600mm (6"-24")

- Custom length on request

Pressure: Up to 20 bar (300 psi). Higher pressure available

Movement: Large axial, lateral and angular movements

Temperature: 149°C (300°F) continuous operating temperature

Materials: See rubber materials (Page 79)

Dismantling Rings

Drilling Pattern: ANSI B16 Cl 150, ANSI B16.5 Cl 300, PN10, PN16, PN25 (See Page 29-30) - Others available

Materials: See metal materials (Page 79)

Coating: Hot-dip galvanised, special UV protective paint

Dismantling Joint Accessories & Options

Rubber Arch: Filled option

Optional: Vacuum ring (In compliance with PED 2014/68/EU, FSA Technical Handbook and ASTM F1123 - 87.)

Protective Coatings: special UV protective paint

Protective Covers: Thor-Shield cover (See Page 34)

Ordering information see page 82

Installation of Equipment in a Piping System



Thorburn's Series 62HP-DJ and 62HPWXX-DJ rubber dismantling expansion joints simplify the installation or removal of valves and other equipment in a piping system by compressing or extending the dismantling joint. Thorburn Rubber dismantling joints (like a rubber expansion joint) have the added benefit of the ability to accommodate thermal movement, vibration and ground settling after the equipment has been installed.

Thorburn rubber dismantling joints facilitate the installation or removal of pipe valves in a piping system

Rubber dismantling joints accommodate required axial adjustment and the movement mechanism can be locked at the required length. Not only does this system allow for fast, easy maintenance of valves, pumps and other pipeline equipment, it simplifies future pipe work modifications and reduces downtime when changes to the pipeline are required.

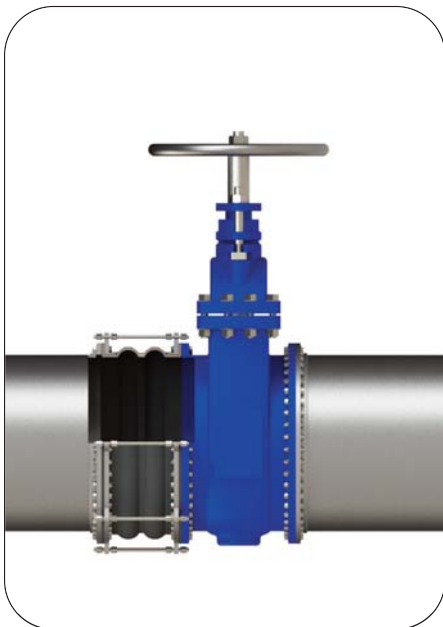

Thorburn's dismantling joint can function as an expansion joint once installed in a piping system and can accommodate thermal movement, vibration and ground settling

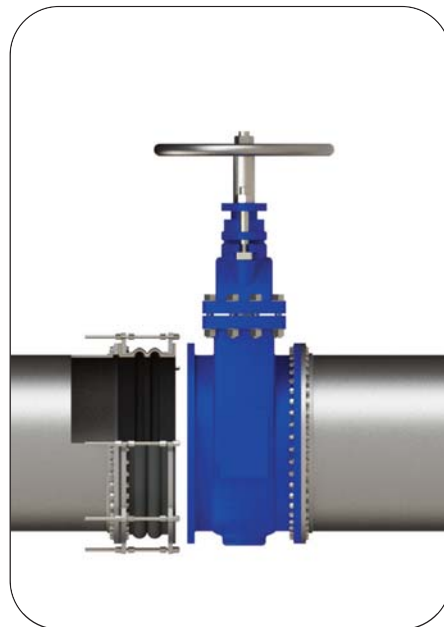

Thorburn dismantling joint engaging its movement mechanism to compress the joint to allow for space between the valve and the dismantling joint

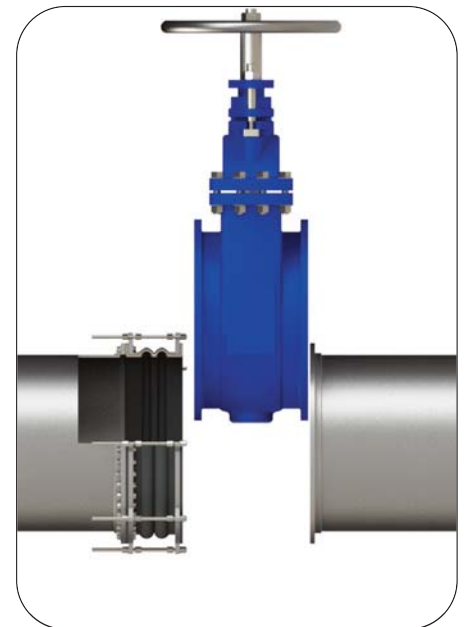

After Thorburn's dismantling joint has provided adequate space, the valve can easily be removed from the piping system

Definitions

Abrasion Resistance: The ability to withstand the wearing effect of a rubbing surface. In elastomers, abrasion is a complicated process, often affected more by compounding and curing than by the elastomer. Soft, resilient compounds, such as pure gum rubber, are frequently specified.

Abrasive Wear: Damage caused by being rubbed by a foreign object; a wearing away by friction of solids.

Absorption: The process of taking in fluid. Joint materials are often compared with regard to relative rates and total amounts of absorption as they pertain to specific fluids.

Accelerated Life Test - Accelerated Aging Test: a method designed to approximate in a short time the deteriorating aging effects obtained under normal service conditions.

Acid Resistant: The ability to withstand the action of acids within certain limits of concentration and temperature.

Active Length: The portion of the flexible part of the joint that is free to move. Also called flex length.

Adhesion: The strength of bond between cured rubber surfaces or cured rubber surface and a non-rubber surface.

Adhesion Failure: The separation of two bonded surfaces at an interface.

Air Flow: the volume of air that can flow through an expansion joint in a given time period (see CFM)

Ambient Temperature: The external environment temperature adjacent to the external face of the expansion joint.

Ambient /Atmospheric Conditions: The surrounding conditions, such as temperature, pressure, and corrosion, to which the expansion joint assembly is exposed.

Amplitude of Vibration and/or Movement: the distance of reciprocating motion of an expansion joint assembly. Half this deflection occurs on each side of the normal expansion joint centerline.

Anchor: Terminal point or fixed point in a piping system from which directional movement occurs.

Angular Deflection/ Movement: The movement which occurs when one flange of the expansion joint is moved to an out of parallel position with the other flange. Such movement is measured in degrees.

ANSI: American National Standards Institute

API: American Petroleum Institute

Aramid Fibers: a class of heat-resistant and strong synthetic fibers

Arch: That portion of an expansion joint which accommodates the movement of the joint.

Assembly: a general term referring to any expansion joint coupled with end fittings of any style attached to one or both ends.

ASTM: American Society for Testing and Materials

Autoclave: an apparatus using superheated high pressure steam for sterilization, vulcanization and other processes.

Atmospheric Cracking: Cracks produced on surface of rubber articles by exposure to atmospheric conditions, especially sunlight, ozone and pollution.

Average Burst: Used by the manufacturer to determine Maximum Allowable Working Pressure.

Axial Compression: The dimensional reduction or shortening in the face-to-face parallel length of the joint measured along the longitudinal axis.

Axial Elongation/extension: The dimensional increase or lengthening of face-to-face parallel length of the joint measured along the longitudinal axis.

Axial Movement: compression or elongation along the longitudinal axis.

Back-up Rings: Refer to Retaining rings

Baffle (Flow Liner): A product that consists of a sleeve extending through the bore of an expansion joint with a full face flange on one end. Constructed of hard rubber, metal or fluoroplastic; it reduces the frictional wear of the expansion joint and provides smooth flow, reducing turbulence.

Bearing Point: See *Fixed Point*. The point at which the piping system is anchored.

Bellows: The portion of an expansion joint which accommodates the movement of the joint. It may be convoluted or flat (see also Active length)

Bench Test: A modified service test in which the service conditions are approximated, but the equipment is conventional laboratory equipment and not necessarily identical with that in which the product will be employed.

Bending Modulus: A force required to induce bending around a given radius; hence a measure of stiffness.

Bias Angle: the angle at which the reinforcement, either fabric or cord, is applied to the expansion joint relative to the horizontal axis.

Blister: A raised spot on the surface or a separation between layers, usually forming a void or air-filled space in the rubber article.

Bloom: A natural discoloration or change in appearance of the surface of a rubber product caused by the migration of a liquid or solid to the surface. Examples: sulfur bloom, wax bloom.

Body: See *Carcass*

Body Rings: Solid steel rings embedded in the carcass used as strengthening members of the joint.

Body Wire: normally a round or flat wire helix embedded in the expansion joint wall to increase strength or to resist collapse.

Bolt Hole Circle: See *Bolt Hole Pattern or Drill Pattern*

Bolt Hole Pattern or Drill Pattern: The location of bolt holes in the expansion joint flanges, where joint is to be bolted to mating flanges.

Bolt Torque: The torque with which bolts must be fastened. This varies according to bolt dimensions, bolt lubrication, flange pressure etc.

Boot or Belt: The flexible element of an expansion joint.

Bore: A fluid passageway, normally the inside diameter of the expansion joint.

Brand: a mark or symbol identifying or describing a product and/or manufacturer, that is embossed, inlaid or printed.

Burst: A rupture caused by internal pressure

Burst pressure: the pressure at which rupture occurs.

Burst Test: A test to measure the pressure at which an expansion joint bursts.

C of C or COC: Certificate of Compliance or conformance: a document typically signed and dated pertaining to a particular lot or purchase order of items(s), which describes any standards, specifications, tests, materials and/or performance attributes which the referenced item(s) have met or will meet.

Calender: A three-roll or four-roll piece of equipment used to produce elastomer plies for an expansion joint at the thickness and width required; also used to skim elastomer onto reinforcing cord or fabric.

Capped End: A seal on the end of a sleeve joint or flange to protect internal reinforcement.

Carcass: The carcass or body of the expansion joint consists of fabric and, when necessary, metal reinforcement.

Cemented Bolt Hole: A method of sealing exposed fabric in a bolt hole.

Cemented Edge: An application of cement around the edges of an expansion joint with or without internal reinforcement for protection or adhesion. (A form of Capped End.)

CFM: cubic feet per minute

Chalking: Formation of a powdery surface condition due to disintegration of surface binder or elastomer, due in turn to weathering or other destructive environments.

Checking Cracks: produced on surface of rubber articles by exposure to atmospheric conditions, especially sunlight, ozone and pollution.

Chemical Resistance: The ability of a particular polymer, rubber compound, or metal to exhibit minimal physical and/or chemical property changes when in contact with one or more chemicals for a specified length of time, at specified concentrations, pressure, and temperature.

Cloth Impression: impression formed on the rubber surface during vulcanization by contact with fabric jacket or wrapper.

Cold Flow: Permanent deformation under stress.

Cold Pe-Set: Dimension that flexible elements are deflected to in order to ensure that desired movements will take place.

Compensator: A non-metallic expansion joint is a flexible connector fabricated of natural or synthetic elastomers, fluoroplastics and fabrics and, if necessary, metallic reinforcements to provide stress relief in piping systems due to thermal and mechanical vibration and/or movements.

Compound: the mixture of rubber or plastic and other materials, which are combined to give the desired properties when used in the manufacture of a product.

Compression Set: The deformation which remains in rubber after it has been subjected to and released from a specific compressive stress for a definite period of time, at a prescribed temperature.

Compression Sleeves: Pipe sleeves or inside nuts can be installed on the control rods. The purpose of the sleeve is to prevent excessive compression in the expansion joint.

Compression Stops: See *Compression sleeves*. Concurrent Movements: Combination of two or more types (axial, angular or lateral) of movements.

Conductive: An expansion joint material having qualities of conducting or transmitting heat or electricity. Most generally, applied to rubber products capable of conducting static electricity.

Connector: Another term for expansion joint

Continuous Temperature Rating: Temperature at which an expansion joint may be operated continuously with safety

Control Rods or Units: Devices usually in the form of tie rods, attached to the expansion joint assembly whose primary function is to restrict the bellows axial movement range during normal operation. In the event of a main anchor failure, they are designed to prevent bellows over-extension or over-compression while absorbing the static pressure thrust at the expansion joint, generated by the anchor failure.

Convolution: That portion of an expansion joint which accommodates the movement of the joint.

Copolymer: a blend of two polymers

Corrosion resistance: ability of the materials to resist chemical attack.

Coupling: Another term for expansion joint

Cover: The exterior surface of the expansion joint formed from natural or synthetic rubber, depending on service requirements. The prime function of the cover is to protect the carcass from outside damage or abuse.

CR: Chloroprene Rubber; ASTM designation for Neoprene; a rubber elastomer.

Cracking: Cracks produced on surface of rubber articles by exposure to atmospheric conditions, especially sunlight, ozone and pollution.

CSM: ASTM designation for chloro-sulfonyl-polyethylene; a rubber elastomer

Cuff End: An expansion joint without flanges. Used to slip over the pipe O.D. and secured with clamps.

Curing: the act of vulcanization.

Cycle Life: The cumulative number of times the flexible element moves from neutral to extended or compressed position and then back again until failure.

Date Code: any combination of numbers, letters, symbols or other methods used by a manufacturer to identify the time of manufacture of a product.

Design Pressure/Vacuum: The maximum pressure or vacuum that the expansion joint is designed to handle during normal operating conditions.

Design Temperature: The maximum high or low temperature that the expansion joint is designed to handle during normal operating conditions. Not to be confused with excursion temperature.

Diameter (Inside): The actual inside diameter of an expansion joint which may be different from the nominal pipe size.

DIN: Deutsches Institut für Normung; DIN, the German Institute for Standardization, is the acknowledged national standards body that represents German interests in European and international standards organizations.

Directional Anchor: A directional or sliding anchor is one which is designed to absorb loading in one direction while permitting motion in another.

Displacement: the amount of motion applied to an expansion joint for axial motion and parallel offset and angular misalignment.

Double Expansion Joint: Also known as a Universal Expansion Joint designed to permit extension, compression, lateral and angular movements. The arrangement consists of two rubber expansion joints connected by a center spool with restraint hardware.

Drain: A fitting to drain the expansion joint of liquids that collect at the lowest point.

Drill Pattern: The location of bolt holes on the joint and mating flanges to which the expansion joint and mating flanges will be attached. Usually meets a specification.

Duck: A durable, closely woven fabric.

Durometer: A measurement of the hardness of rubber and plastic compounds.

Ears: Lugs or gusset plates that a control rod goes through to be attached to the mating pipe flanges.

Eccentricity: A condition in which two diameters deviate from a common center.

Effective Length: The portion of the flexible part of the joint that is free to move.

Effective thrust area: Cross-sectional area described by the mean diameter of the arch/convolution if present.

EJMA: Expansion Joint Manufacturers Association (Metal Expansion Joints).

Elasticity: The ability to return to the original shape after removal of load without regard to the rate of return.

Elastomer: A natural rubber or synthetic polymer having elastic properties that can recover its original shape after deformation.

Electrical Resistivity: The resistance between opposite parallel faces of material having a unit length and unit cross section. Typically measured in Ohms/cm.

Elongation: Increase in length expressed numerically as a fraction or a percentage of initial length.

Enlarged End: An end with inside diameter greater than that of the main body of an expansion joint.

EPDM: ASTM designation for Ethylene-Propylene-Diene-Terpolymer; a rubber elastomer.

Excursion Temperature: The temperature the system could reach during an equipment failure. Excursion temperature should be defined by maximum temperature and time duration of excursion.

Expansion Joint: A flexible connector fabricated of natural or synthetic elastomers, fluoroplastics and fabrics and, if necessary, metallic reinforcements to provide stress relief in piping systems due to thermal and mechanical vibration and/or movements.

Expansion Joint Assembly: The complete expansion joint, including, where applicable, the flexible element, the exterior hardware and any flow liners or ancillary components.

External Influences: Forces or environment acting on the expansion joint from outside of the process.

External Insulation: Insulation materials applied to the outside of the pipe, not the expansion joint.

Fabric impression: Impressions formed on the outer surface during vulcanization by contact with a fabric wrap.

Face-to-Face (F/F): Dimension between the mating flange faces to which the expansion joint will be bolted. This is also the length of the expansion joint when the system is in the cold position.

Fastening Element: Bolts, nuts, studs, washers and other items for securing a connection.

Fatigue: The weakening or deterioration of a material caused by a repetition of strain.

FDA: U.S. Food and Drug Administration.

FEP: ASTM designation for Fluoro-Ethylene-Propylene.

Field Assembly: A joint that is assembled at the job site.

Filled Arch: Arch-type expansion joints supplied with a bonded-in place soft rubber filler to provide a smooth interior bore. Filled arch joints have a seamless tube so the arch filler cannot be dislodged during service.

Finite Element Analysis (FEA): A computerized method to study a structure and its components to ensure that the design meets the required performance criteria.

Fixed Point: The point at which the piping system is anchored.

Flame retardant: Materials added to compounds to inhibit, suppress or delay the production of flames to prevent the spread of fire.

Flange: The component which is used to fasten the expansion joint into the piping system.

Flanged End: The ends or flanges of an expansion joint so it can be bolted to adjacent flanges.

Flanged Expansion Joint: An expansion joint with flanged ends.

Flange Gasket: A gasket which is inserted between two adjacent flanges to form a sealed connection.

Flex Cracking: A surface cracking induced by repeated bending or flexing.

Flexible Connector: An expansion joint or flexible pipe fabricated of natural or synthetic elastomers, fluoroplastics and fabrics and, if necessary, metallic reinforcements to provide stress relief in piping systems due to thermal and mechanical vibration and/or movements.

Flexible Element: See *Flexible Connector*

Flexible Length: The portion of the flexible part of the joint that is free to move. See *Active Length*.

Flex Life: The cumulative number of times the flexible element moves from the cold to hot position and then back to cold again until failure.

Floating Flange: Metal flange which is grooved to contain the bead on each end of an expansion joint. It is used on spherical expansion joints.

Flow Direction: The direction in which the media is flowing.

Flow Liner: This product consists of a sleeve extending through the bore of the expansion joint attached on one end. Constructed of hard rubber, metal or fluoroplastic; it reduces frictional wear of the expansion joint and provides smooth flow, reducing turbulence.

Flow rate: A volume of media being conveyed in a given time period.

Flow Velocity: The rate of flow through the expansion joint system. Fluorocarbon: A general class of compounds containing fluorine and carbon.

Fluoroelastomers: FKM, FPM, fluorine containing compounds which have excellent resistance to a broad spectrum of oils, gases, fluids and chemicals at elevated temperatures.

Fluoropolymer: A fluorocarbon based polymer with strong carbon-fluorine bonds. PTFE, PFA, FEP

Fluoroplastics: Fluoroplastics are thermoplastic resins of general paraffin structures that have all or some of the hydrogen replaced with fluorine. PTFE, PFA, FEP

Flutter: The action that occurs on the flexible element caused by the turbulence of the system media or vibration in system.

Free Length: The portion of the flexible part of the joint that is free to move. See *Active Length*.

Frequency: The rate at which some event occurs.

Frictioned Fabric: A fabric with a surface treatment which will bond two surfaces together usually by means of a calender with rolls running at different surface speeds. May also be used to adhere to only one surface.

Gas Flow Velocity (see Flow Velocity): The rate of flow through the expansion joint system.

Gimbal Expansion Joint: Gimbal type rubber expansion joints are designed to permit angular rotation in multiple planes. The arrangement consists of two pairs of hinge plates connected with pins to a common gimbal ring and attached to the expansion joints' external or internal hardware.

GPM: gallons per minute

Guide: A pipe guide is framework fastened to some rigid part of the installation which permits the pipeline to move freely in only one direction along the axis of the pipe. Pipe guides are designed primarily for use in applications to prevent lateral deflection and angular rotation.

Gusset Plates: The ears, or lugs that a control rod goes through to be attached to the mating pipe flanges.

Hardness: Measured by the amount of an indenter point of any one of a number of standard hardness testing instruments to penetrate the product. *Also see Durometer.*

Heat Resistance: The ability to resist the deteriorating effects of elevated temperatures.

Helix: Shape formed by spiraling a wire or other reinforcement around the cylindrical body of a rubber pipe.

Hg: The symbol for mercury, used in measuring vacuum, as in, inches of mercury.

Hinged Expansion Joint: Hinged type rubber expansion joints are designed to permit angular rotation in one plane. The arrangement consists of a pair of hinge plates connected with pins and attached to the expansion joints external or internal hardware.

HVAC: heating, ventilation, air conditioning

Hydrostatic Test: Test used to demonstrate system or expansion joint capability. The standard test is 1-1/2 times the Maximum Allowable Pressure, held for 10 minutes, without leaks.

I.D.: the abbreviation for inside diameter

Inches of mercury: The height of a column of mercury used to measure air pressure or vacuum.

Inches of water: The height of a column of water used to measure air pressure or vacuum.

In-Line Pressure Balanced Expansion Joint: Pressure Balanced type rubber expansion joints are designed to absorb compression, lateral and angular movements while resisting the pressure thrust force. The arrangement consists of two or three rubber expansion joints and interconnecting hardware and attached to the external or internal interconnecting hardware. This configuration is designed to function in a straight pipeline.

Inner Ply: The media side ply of the flexible element.

Installed Face-to-Face Distance: Dimension between the mating flange faces to which the expansion joint will be bolted.

Installed Length: See *Installed Face Distance*

Integrally Flanged Type Expansion Joint: An expansion joint in which the joint flanges are made of the same rubber and fabric as the body of the joint.

Intermediate Anchor: An anchor which must withstand the expansion joint thrust due to flow, spring forces, and all other piping loads, but not the thrust due to pressure.

Internal Sleeve: A sleeve extending through the bore of the expansion joint attached on one end. Constructed of hard rubber, metal or fluoroplastic; it reduces frictional wear of the expansion joint and provides smooth flow, reducing turbulence.

ISO: International Organization for Standardization

Joint Cuff: The ends of a sleeve type expansion joint. Used to slip over the pipe O.D. and secured with clamps.

Lateral Movement/Deflection: The relative displacement of the two ends of the expansion joint perpendicular to its longitudinal axis.

Lateral Offset: The distance between two adjacent flanges or faces perpendicular to its longitudinal axis.

Life Cycles: The cumulative number of times the flexible element moves through its motion range until failure.

Lifting Lugs: A lifting device that is attached to the metal portion of the expansion joint for field handling and installation.

Limiting Stress: The load which, when applied, does not exceed the elastic limits of the material and provide a safe operating level.

Limit Rods: Devices usually in the form of tie rods, attached to the expansion joint assembly whose primary function is to restrict the expansion joint axial movement range during normal operation. In the event of a main anchor failure, they are designed to prevent bellows over-extension or over-compression while absorbing the static pressure thrust at the expansion joint, generated by the anchor failure.

Lined Bolt Holes: A method of sealing exposed fabric in a bolt hole.

Liner: A sleeve extending through the bore of the expansion joint attached on one end. Constructed of hard rubber, metal or Fluoroplastic; it reduces frictional wear of the expansion joint and provides smooth flow, reducing turbulence.

Live Length: Active Length (Flex Length): The portion of the flexible part of the joint that is free to move.

Main Anchor: A main anchor is one which must withstand all of the thrust due to pressure, flow and spring forces of the system.

Mandrel: A form used for sizing and to support the expansion joint during fabrication and/or vulcanization. It may be rigid or flexible.

Mandrel Built: An expansion joint fabricated and/or vulcanized on a mandrel.

Manufactured length: The manufactured width of the flexible element measured from joint end to end.

Manufacturer's identification: A code or symbol used on or in an expansion joints to indicate the manufacturer.

Maximum Burst: Is the theoretical (predetermined) burst pressure of an expansion joint.

Maximum Design Temperature: The maximum temperature that the system may reach during normal operating conditions. This is not to be confused with excursion temperature.

MAWP: Maximum Allowable Working Pressure

Mean Diameter: The midpoint between the inside diameter and the outside diameter of an expansion joint.

Media, Medium: The substance conveyed through a system.
Membrane: A ply of material.

Metal Reinforcement: Wire or solid steel rings embedded in the carcass are frequently used as strengthening members of the joint. The use of metal sometimes raises the rated working pressure and can supply rigidity to the joint for vacuum service.

Minimum temperature: The lowest temperature to which the system will be exposed.

Misalignment: The out of line condition that exists between the adjacent faces of the flanges.

Molded Type Expansion Joint: An expansion joint that is cured in a mold, not wrapped finished.

Motion Indicators: Devices attached to an expansion joint to record the amount of motion of the joint during operation

Movements: The dimensional changes which the expansion joint is designed to absorb, such as those resulting from thermal expansion or contraction.

Nitrile Rubber: Buna-N, NBR, used heavily for oil, fuel and chemical resistance.

Noise Attenuation: The reduction of noise transmitted through the piping systems by the expansion joint.

Nominal: A size indicator for reference.

Nominal Thickness: The design value.

Non-conductive: Having the ability to stop the flow of electricity.

Non-Metallic Expansion Joint: A flexible connector principally fabricated of natural or synthetic elastomers, fluoroplastics and fabrics. If necessary, it may include metallic reinforcements.

NSF: National Sanitation Foundation

Nylon: A material of the polyamide family, which may be woven or cord type, used in the construction of an expansion joint.

O-A-L: Alternative term for the "face to face" dimension or the overall length of an expansion joint.

O.D.: The abbreviation for outside diameter.

OE/OEM: Original Equipment Manufacturer.

Offset-lateral, parallel: The offset distance between two adjacent flanges or faces.

Oil Resistant: The ability to withstand the deteriorating effects of oil on the physical properties.

Oil Swell: The increase in volume of rubber due to absorption of oil.

Open Arch: An arch or convolution of an expansion joint that is not filled.

Operating Pressure/Vacuum: The pressure at which the system works under normal conditions. This pressure may be positive pressure or vacuum.

Operating Temperature: The temperature at which the system will generally operate during normal conditions.

Outer Cover: The exterior surface of the expansion joint formed from natural or synthetic rubber, depending on service requirements. The prime function of the cover is to protect the carcass from outside damage or abuse.

Overall length (OAL): Dimension between the mating flange faces to which the expansion joint will be bolted.

Oxidation: The combination of a substance or material with oxygen causing a change in its appearance and condition.

Ozone cracking: Cracks produced on surface of rubber articles by exposure to atmospheric conditions.

Ozone resistance: The ability of a material to resist the deteriorating effects of ozone exposure.

Pantograph Control Mechanism: A special metal construction using a "scissors" principle to distribute large movements uniformly between two or more flexible elements in line.

Permanent Set: The deformation remaining after a specimen has been stressed in tension or compression and then released for specified periods of time.

Permeation: The penetration of a liquid or gas through the expansion joint material.

Permeability: The ability of a liquid or gas to pass through the expansion joint material.

Pipe Alignment Guide: A pipe alignment guide is framework fastened to some rigid part of the installation which permits the pipeline to move freely in only one direction along the axis of the pipe. Pipe alignment guides are designed primarily for use in applications to prevent lateral deflection and angular rotation.

Pipe Section: The section of a pipeline that is between two anchor points.

Pipe Sleeve: Pipe sleeves or inside nuts can be installed on the control rods. The purpose of the sleeve is to prevent excessive compression in the expansion joint. The length of this pipe sleeve should be such that the expansion joint cannot be compressed beyond the maximum allowable compression figure stated by the manufacturer.

Plain Ends: An end with inside diameter the same as that of the main body, as in straight ends.

Ply: One concentric layer or ring of material, such as fabric plies in an expansion joint.

Polymer: A chemical compound where molecules are bonded together in long repeating chains.

Pre-Assembled Joint: The combination of the metal framework and a flexible element, factory assembled into a single assembly.

Pre-Compression: Compressing the expansion joint (shortening the F/F) so that in the cold position the joint has a given amount of compression set into the joint. The purpose of pre-compression is to allow for unexpected or additional axial extension. This is performed at the job site.

Pre-Set: The dimension which joints are expanded, compressed or laterally offset in the installed position, in order to ensure that system design movements will take place.

Pressure Balanced Expansion Joint: An expansion joint designed to absorb compression, lateral and angular movements while resisting the pressure thrust force. The arrangement consists of two or three rubber expansion joints with interconnecting hardware. It can be designed to function as an in-line or elbow configuration.

Proof Pressure Test: Hydrostatic test up to 1.5 times the Maximum Allowable Working Pressure of the product, for a minimum of 10 minutes without leaks.

Protective Shipping Cover: Material used to protect the expansion joint during shipment and installation.

Pulsation: The action that occurs on the expansion joint caused by the turbulence of the system fluids, gases or vibration set up in the system.

Pump Connector: An expansion joint used to connect a pump to a pipeline.

Psi: Pounds per Square Inch

PTFE: Polytetrafluoroethylene, a strong non-flameable synthetic resin produced by the polymerization of Tetrafluoroethylene. It has excellent chemical resistance.

Quality conformance inspection or test: The examination of samples from a production run to determine adherence to given specifications.

Reducers: Reducing expansion joints are used to connect piping unequal diameters. They may be manufactured as a concentric reducer or as an eccentric reducer. Reducers in excess of 20 degrees are not desirable.

Reinforcement: The carcass or body of the expansion joint consisting of fabric and, when necessary, metal reinforcement.

Resultant Movement: The net effect of concurrent movement.

Reinforcing Rings: Solid steel rings embedded in the carcass used as strengthening members of the joint.

Retaining Rings: Rings used to distribute the bolting load and assure a pressure tight seal. They are coated for corrosion resistance and drilled as specified. The rings are installed directly against the back of the flanges of the joint and bolted through to the mating flanges of the pipe.

RMA: The Rubber Manufacturers Association Inc.

SAE: The Society of Automotive Engineers. This organization has developed methods of testing and classifying elastomers.

Safety factor: A ratio used to establish the minimum burst strength of an expansion joint based on the design pressure.

SBR: ASTM designation for Styrene-Butadiene: a rubber elastomer.

Service Life: Estimated time the expansion joint will operate without the need of replacement.

Shelf/storage life: The period of time prior to use during which an expansion joint retains its intended performance capability.

Simultaneous Movements: Combination of two or more types of movements.

Site Assembly: An expansion joint which is assembled at the job site.

Sleeve Type Expansion Joint: An expansion joint which has sleeved or cuffed ends for securing to the pipe as opposed to flanged ends.

Soft Cuffs/Soft Ends: An end in which the rigid reinforcement of the body, usually wire, is omitted.

Specific Gravity: The ratio of the weight of a given substance to the weight of an equal volume of water at a specified temperature.

Spool Type: An expansion joint with flanged ends.

Spring Rate: The force required to move the expansion joint a certain distance in compression, extension or laterally. It is most often expressed in lb/in.

Stabilizer: An external attachment to the expansion joint assembly, whose primary function is to increase the stability of a universal expansion joint assembly.

Static Wire: A wire incorporated in an expansion joint for conducting or transmitting static electricity.

Straight End: An end with inside diameter the same as that of the main body.

Sun Checking: Cracks produced on surface of rubber articles by exposure to atmospheric conditions, especially sunlight, ozone and pollution.

Surge (spike): A rapid rise in pressure.

Tapers: Reducing expansion joints are used to connect piping with unequal diameters. They may be manufactured as a concentric reducer or as an eccentric reducer. Reducers in excess of 20 degrees are not desirable.

Tensile Strength: Ability of a material to resist or accommodate loads until the breakage point.

Thermal Movement: Movements created within the piping system by thermal expansion. Can be axial compression, axial extension, lateral, angular or torsional.

Top Hat Liner: A product that consists of a sleeve extending through the bore of an expansion joint with a full face flange on one end.

Torsional Movement: The twisting of one end of an expansion joint with respect to the other end about its longitudinal axis. Such movement is measured in degrees.

Torsional Rotation: See *Torsional Movement*

Transverse Movement: The movement or relative displacement of the two ends of the expansion joint perpendicular to its longitudinal axis.

Tube: The innermost continuous rubber or synthetic element of an expansion joint.

Under Gauge: Thinner than the thickness specified.

Universal Expansion Joint: Universal type rubber expansion joints are designed to permit extension, compression, lateral and angular movements. The arrangement consists of two rubber expansion joints connected by a center spool with restraint hardware.

UV Resistance: The ability of a material to resist the deteriorating effects of exposure to ultraviolet rays.

Vacuum: Pressures below atmospheric pressure.

Vacuum Resistance: Expansion joint's ability to resist negative gauge pressure.

Van Stone Flange: A loose, rotating type flange, sometimes called a lap-joint flange.

Velocity Resonance: Vibration due to the elastic response of a high velocity gas or liquid flow.

Volume change: A change in dimensions of a specimen due to exposure to a liquid or vapor.

Volume swell: An increase in volume or linear dimension of a specimen immersed in liquid or exposed to a vapor.

Volumetric expansion: The volume increase of an expansion joint when subjected to internal pressure.

Wear Resistance: The ability of a material to withstand abrasive particles without degradation or wear.

WG: Water gauge or column of water used to measure pressure.
Welding Blanket: A fire resistant blanket that is placed over the expansion joint to protect it from weld splatter during field welding operations.

Wide Arch: A term used for an arch that is wider than the original narrow arch.

Wire gauge: The measurement of how large a wire is in diameter.

Wire Reinforced: Wire embedded in the carcass of an expansion joint frequently used as a strengthening member of the joint. The use of metal can raise the rated working pressure and can supply rigidity to the joint for vacuum service.

Working pressure/ WP: The maximum pressure or vacuum that the expansion joint will be subjected to during normal operating conditions.

Working temperature: The maximum or minimum temperature that the expansion joint will be subjected to during normal operating conditions.

Wrapped Cure (Wrap Marks): Impressions left on the cover surface by the material used to wrap the expansion joint during vulcanization. Usually shows characteristics of a woven pattern and wrapper width edge marks.

Zinc-plated (retaining rings or flanges): A term for a type of Galvanizing

Chemical Resistance	RATING CODE:									
	A Excellent B Good C Fair or Conditional D Unsatisfactory – No data available All ratings are based on 70°F									
	Natural Rubber	SBR	Butyl	Nitrile	Neoprene	Hypalon	EPDM	Viton	X-Linked Polyethylene	Teflon/TFE/FEF
Acetal	C	C	B	D	C	C	B	D	A	A
Acetaldehyde	C	D	A	D	C	C	A	D	A	A
Acetamide	C	C	A	B	B	B	A	B	A	A
Acetate Solvents	C	D	C	D	D	D	C	D	A	A
Acetic Acid, 10%	B	B	B	B	C	C	B	C	A	A
Acetic Acid, 30%	D	D	B	D	C	B	A	C	A	A
Acetic Acid, 50%	D	D	B	C	C	D	A	D	A	A
Acetic Anhydride	D	D	B	D	C	D	B	D	A	A
Acetic Anhydride	D	D	B	D	D	D	B	D	A	A
Acetic Ester (Ethyl Acetate)	D	D	B	D	D	D	B	D	A	A
Acetic Ether (Ethyl Acetate)	D	D	B	D	D	C	B	D	A	A
Acetic Oxide (Acetic Anhydride)	D	D	B	D	D	D	B	D	A	A
Acetone	B	C	A	D	C	C	A	D	A	A
Acetophenone	C	D	A	D	D	D	A	D	A	A
Acetyl Acetone	B	D	B	D	D	D	B	D	A	A
Acetyl Chloride	D	D	C	D	D	D	C	B	B	A
Acetylene	D	D	A	A	B	B	B	A	A	A
Acrylonitrile	C	D	D	D	C	C	D	D	A	A
Air	A	A	A	A	A	A	A	A	A	A
Alcohols Aliphatic	A	B	A	A	A	A	A	C	A	A
Alcohols, Aromatic	C	D	D	C	C	D	D	A	A	A
Alk-Tri (Trichlorethylene)	D	D	D	D	D	D	A	A	A	A
Allyl Alcohol	A	B	A	A	A	A	A	B	A	A
Allyl Bromide	D	D	D	D	D	D	D	B	B	A
Allyl Chloride	D	D	D	D	D	D	D	B	B	A
Alum (Aluminum Potassium Sulfate)	A	A	A	A	A	A	A	A	A	A
Aluminum Acetate	C	C	A	C	C	B	A	A	A	A
Aluminum Chloride	A	A	A	A	A	A	A	A	A	A
Aluminum Fluoride	A	A	A	A	A	A	A	A	A	A
Aluminum Hydroxide	A	A	A	A	A	A	A	A	A	A
Aluminum Nitrate	A	A	A	A	A	A	A	A	A	A
Aluminum Phosphate	A	A	A	A	A	A	A	A	A	A
Aluminum Sulfate	A	A	A	A	A	A	A	A	A	A
Ammonia Anhydrous	A	C	A	A	A	B	A	D	A	A
Ammonia Gas (150°F)	Anhydrous Ammonia Hose Only									
Ammonia in Water	B	B	B	B	B	B	A	B	A	A
Ammonia Liquid	B	B	A	A	A	A	A	A	A	A
Ammonia, Gas (Cold)	Anhydrous Ammonia Hose Only									
Ammonium Carbonate	A	A	A	C	A	A	A	A	A	A
Ammonium Chloride	A	A	A	A	A	A	A	A	A	A
Ammonium Hydroxide	B	B	B	B	A	B	B	A	A	A
Ammonium Metaphosphate	A	A	A	A	A	A	A	A	A	A
Ammonium Nitrate	B	A	A	A	A	A	A	A	A	A
Ammonium Nitrite	A	A	A	A	A	A	A	A	A	A
Ammonium Persulfate	A	D	A	D	A	A	A	A	A	A
Ammonium Phosphate	A	A	A	A	A	A	A	A	A	A
Ammonium Sulfate	A	A	A	A	A	A	A	A	A	A
Ammonium Sulfide	A	A	A	A	A	A	A	A	A	A
Ammonium Sulfite	A	A	A	A	A	A	A	A	A	A
Ammonium Thiocyanate	A	A	A	A	A	A	A	A	A	A
Ammonium Thiosulfate	A	A	A	A	A	A	A	A	A	A
Amyl Acetate	C	D	B	D	D	D	B	D	A	A
Amyl Acetone	D	D	B	D	D	D	B	D	A	A
Amyl Alcohol	A	A	A	A	A	A	A	A	A	A

Chemical Resistance	RATING CODE:									
	A Excellent B Good C Fair or Conditional D Unsatisfactory – No data available All ratings are based on 70°F									
	Natural Rubber	SBR	Butyl	Nitrile	Neoprene	Hypalon	EPDM	Viton	X-Linked Polyethylene	Teflon/TFE/FEF
Amyl Borate	D	D	D	A	A	C	D	A	A	A
Amyl Chloride	D	D	D	D	D	D	D	A	A	A
Amyl Chloronaphthalene	D	D	D	D	D	D	D	A	A	A
Amyl Napthalene	D	D	D	D	D	D	D	A	A	A
Amyl Oleate	D	D	B	D	D	D	B	C	A	A
Amyl Phenol	D	D	D	D	D	D	D	A	A	A
Amylamine	See Ammonia									
Anethole	D	D	D	D	D	D	D	B	B	A
Aniline	D	D	B	D	C	C	D	B	A	A
Aniline Dyes	B	B	B	C	B	B	B	B	A	A
Aniline Hydrochloride	B	C	B	B	D	D	B	B	A	A
Animal Fats	D	D	B	A	B	B	B	A	A	A
Animal Grease	D	D	D	B	B	D	C	A	A	A
Animal Oils	D	D	B	A	D	D	C	A	A	A
Ansul Ether	D	D	C	C	D	D	C	D	A	A
Antifreeze (Ethylene Glycol)	A	A	A	A	A	A	A	A	A	A
Antimony Pentachloride	D	D	C	D	D	D	C	A	B	A
Antimony Trichloride	D	D	A	B	B	B	B	A	A	A
Aqua Regia	D	D	D	D	D	C	C	B	D	A
Aromatic Hydrocarbons	D	D	D	C	D	D	D	A	A	A
Arquad	A	A	A	A	A	A	A	A	A	A
Arsenic Acid	A	A	A	A	A	A	A	A	A	A
Arsenic Chloride	D	D	B	D	B	D	B	D	D	A
Arsenic Trichloride	D	D	B	D	B	D	B	D	D	A
Asphalt	D	D	D	A	B	D	D	A	B	A
Astm #1 Oil	D	D	D	A	A	B	D	A	A	A
Astm #2 Oil	D	D	D	A	B	C	D	A	A	A
Astm #3 Oil	D	D	D	A	B	C	D	A	A	A
Aviation Gasoline	D	D	D	A	C	D	D	A	A	A
Barium Carbonate	A	A	A	A	A	A	A	A	A	A
Barium Chloride	A	A	A	A	A	A	A	A	A	A
Barium Hydroxide	A	A	A	A	A	A	A	A	A	A
Barium Sulfate	A	A	A	A	A	A	A	A	A	A
Barium Sulfide	A	A	A	A	A	A	A	A	A	A
Beer	F.D.A. Tube Required									
Beet Sugar Liquors	A	A	A	A	A	A	A	A	A	A
Benzaldehyde	D	D	B	D	D	D	B	D	A	A
Benzene (Benzol)	D	D	D	C	C	D	D	A	A	A
Benzene Sulfonic Acid	D	D	D	B	A	A	C	A	A	A
Benzene Solvent (Ligroin)	D	D	D	A	A	C	D	A	A	A
Benzoic Acid	D	D	B	D	B	B	B	A	A	A
Benzoic Aldehyde	D	D	D	D	D	D	D	D	A	A
Benzotrithloride	D	D	D	D	D	D	D	B	B	A
Benzoyl Chloride	D	D	D	D	D	D	D	B	B	A
Benzyl Acetate	D	B	B	D	D	B	B	D	A	A
Benzyl Alcohol	B	B	B	D	B	B	B	A	A	A
Benzyl Chloride	D	D	C	D	D	D	D	A	A	A
Bichromate of Soda (Sodium Dichromate)	D	D	A	D	B	B	C	A	A	B
Bichromate of Soda (Sodium Bichromate)	D	D	A	D	B	B	C	A	A	A
Black Sulfate Liquor	B	B	A	B	A	B	A	A	A	A
Blast Furnace Gas	D	D	C	C	B	B	C	A	A	B
Bleach Solutions	D	D	B	D	D	C	B	B	B	A
Borax	B	B	A	B	A	A	A	A	A	A
Bordeaux Mixture	B	B	A	A	A	A	A	A	A	A

Chemical Resistance	RATING CODE:									
	A Excellent B Good C Fair or Conditional D Unsatisfactory – No data available All ratings are based on 70°F									
	Natural Rubber	SBR	Butyl	Nitrile	Neoprene	Hypalon	EPDM	Viton	X-Linked Polyethylene	Teflon/TFE/FEP
Brandy	F.D.A. Tube Required									
Brine	A	A	A	A	A	A	A	A	A	A
Bromine	D	D	D	D	D	C	D	C	D	A
Bromine Water	D	D	B	C	B	A	B	A	A	A
Bromobenzene	D	D	D	D	D	D	D	B	C	A
Bunker Oil	D	D	D	A	B	D	D	A	A	A
Butane	Use Butane-Propane Hose Only									
Butanol (Butyl Alcohol)	A	A	A	A	A	A	A	A	A	A
Butter (Non-F.D.A.)	C	C	B	A	A	A	B	A	A	A
Butyl Acetate	D	D	B	D	D	D	C	D	A	A
Butyl Acrylate	D	D	D	D	D	D	D	D	B	A
Butyl Benzene	D	D	D	D	D	D	D	A	A	A
Butyl Bromide	D	D	D	D	D	D	D	B	B	A
Butyl Butyrate	D	D	C	D	D	D	B	C	B	A
Butyl Carbitol	D	D	A	B	B	B	A	A	A	A
Butyl Cellosolve	D	D	A	B	B	B	A	D	A	A
Butyl Chloride	D	D	C	D	D	D	D	A	B	A
Butyl Ether	D	D	C	B	B	B	C	D	A	A
Butyl Ethyl Acetaldehyde	D	D	C	D	D	D	D	D	A	A
Butyl Ethyl Ether	D	D	C	D	D	B	C	C	A	A
Butyl Oleate	D	D	B	D	D	D	B	A	A	A
Butyl Phthalate	D	D	C	D	D	D	C	C	A	A
Butyl Stearate	D	D	C	B	D	D	C	A	A	A
Butylamine	See Ammonia									
Butyric Acid	C	D	C	C	C	B	C	C	A	A
Butyric Acid	C	D	C	C	C	B	C	C	A	A
Butyric Anhydride	C	D	C	C	D	B	C	C	A	A
Butyraldehyde	C	D	D	D	D	D	D	D	A	A
Calcium Acetate	C	D	A	D	D	D	A	D	A	A
Calcium Bisulfate	A	A	A	A	A	A	A	A	A	A
Calcium Bisulfite	A	A	A	A	A	A	A	A	A	A
Calcium Carbonate	A	A	A	A	A	A	A	A	A	A
Calcium Chloride	A	A	A	A	A	A	A	A	A	A
Calcium Hydroxide	A	B	A	B	A	B	A	C	A	A
Calcium Hypochlorite	D	D	B	D	D	C	B	A	B	A
Calcium Nitrate	A	A	A	A	A	A	A	A	A	A
Calcium Sulfate	A	A	A	A	A	A	A	A	A	A
Calcium Sulfide	A	A	A	A	A	A	A	A	A	A
Calcium Sulfite	A	A	A	A	A	A	A	A	A	A
Caliche Liquor (Crude Sodium Nitrate)	A	A	A	A	A	A	A	A	A	A
Cane Sugar Liquors (Non F.D.A.)	D	D	A	D	A	B	B	B	A	A
Carbitol	D	D	A	D	A	B	B	B	A	A
Carbitol Acetate	D	D	B	D	D	D	B	D	A	A
Carbolic Acid (Phenol)	D	D	B	C	C	C	B	A	A	A
Carbon Bisulfide	See Carbon Disulfide									
Carbon Dioxide	A	A	A	A	A	A	A	A	A	A
Carbon Disulfide	D	D	D	D	D	D	D	A	A	A
Carbon Monoxide	A	A	A	A	A	A	A	A	A	A
Carbon Tetrachloride	D	D	D	C	D	D	D	A	C	A
Carbon Tetrafluoride	D	D	D	C	D	D	D	A	C	A
Carbonic Acid	A	A	A	A	A	A	A	A	A	A
Castor Oil	C	D	B	A	B	C	B	A	A	A
Caustic Potash (Potassium Hydroxide)	A	B	A	A	B	A	A	C	A	A
Caustic Soda (Sodium Hydroxide)	A	B	A	A	A	A	A	C	A	A

Chemical Resistance	RATING CODE:									
	A Excellent B Good C Fair or Conditional D Unsatisfactory – No data available All ratings are based on 70°F									
	Natural Rubber	SBR	Butyl	Nitrile	Neoprene	Hypalon	EPDM	Viton	X-Linked Polyethylene	Teflon/TFE/FEP
Cellosolve	D	D	B	B	A	B	B	C	A	A
Cellulose Acetate	C	D	B	D	C	C	B	D	B	A
Cellulube	C	D	B	D	D	D	A	C	A	A
China Wood Oil (Tung Oil)	D	D	B	A	B	B	B	A	A	A
Chlorinated Hydrocarbons	D	D	D	D	D	D	D	A	B	A
Chlorine Dioxide	D	D	D	D	D	C	D	A	B	A
Chlorine Gas (Dry)	C	C	C	C	D	B	C	B	B	A
Chlorine Water Solutions	C	D	C	D	D	B	C	A	A	A
Chloroacetic Acid	B	D	C	D	D	D	C	C	A	A
Chloroacetone	D	D	B	D	D	D	C	D	A	A
Chlorobenzene	D	D	D	D	D	D	D	A	B	A
Chlorobutadiene	D	D	D	D	D	D	D	A	B	A
Chlorobutane	D	D	D	D	D	D	D	A	B	A
Chloroform	D	D	D	D	D	D	D	A	B	A
Chloropentane	D	D	D	D	C	D	D	A	A	A
Chlorophenol	D	D	D	D	D	D	D	B	B	A
Chloropropanone	D	D	C	D	D	D	C	D	A	A
Chlorosulfonic Acid	D	D	D	D	D	C	D	D	B	A
Chlorothene (Trichloroethane)	D	D	D	D	D	D	D	A	B	A
Chlorotoluene	D	D	D	D	D	D	D	A	B	A
Chromic Acid	D	D	D	D	D	A	C	C	A	A
Citric Acid	A	A	A	B	B	A	A	A	A	A
Coal Oil	D	D	D	A	B	D	D	A	A	A
Coal Tar	D	D	D	A	B	B	B	A	A	A
Coal Tar Naptha	D	D	D	C	C	D	D	A	A	A
Cobalt Chloride	A	A	A	A	A	A	A	A	A	A
Coconut Oil	D	D	B	A	B	B	A	A	A	A
Cod Liver Oil	D	D	A	A	B	B	A	A	A	A
Coke Oven Gas	D	D	C	D	D	B	D	A	A	A
Copper Arsenate	A	A	A	A	A	A	A	A	A	A
Copper Chloride	A	A	A	A	A	A	A	A	A	A
Copper Cyanide	A	A	A	A	A	A	A	A	A	A
Copper Nitrate	A	A	A	A	A	A	A	A	A	A
Copper Nitrite	A	A	A	A	A	A	A	A	A	A
Copper Sulfate	C	A	A	A	A	A	A	A	A	A
Copper Sulfide	C	A	A	A	A	A	A	A	A	A
Corn Oil	D	D	B	A	B	B	B	A	A	A
Cottonseed Oil	D	D	A	A	B	A	A	A	A	A
Creosols	D	D	D	C	C	C	D	A	A	A
Creosote (Coal Tar)	D	D	D	B	C	C	D	A	A	A
Creosote (Wood)	D	D	D	B	C	C	D	A	A	A
Cresylic Acid	D	D	D	C	C	C	D	A	A	A
Crude Oil	D	D	D	C	C	C	D	A	A	A
Cumene	D	D	D	A	B	D	D	A	A	A
Cupric Carbonate	D	D	D	C	C	D	D	A	A	A
Cupric Chloride	C	C	A	B	B	B	A	A	A	A
Cupric Nitrate	C	C	A	A	B	A	A	A	A	A
Cupric Nitrite	C	C	A	A	B	A	A	A	A	A
Cupric Sulfate	C	C	A	A	B	A	A	A	A	A
Cyclohexane	C	B	A	A	B	B	A	A	A	A
Cyclohexanol	D	D	D	D	D	D	C	A	A	A
Cyclohexanone	D	D	D	B	D	D	D	A	A	A
Cyclopentane	D	D	D	B	B	D	D	B	A	A
D.M.P. (Dimethyl Phenols)	B	D	D	D	D	D	D	D	C	A

Chemical Resistance	RATING CODE:									
	Natural Rubber	SBR	Butyl	Nitrile	Neoprene	Hypalon	EPDM	Viton	X-Linked Polyethylene	Teflon/TFE/FEF
DDT in Kerosene	D	D	D	C	D	D	D	A	A	A
Decaline (Deklin)	D	D	D	A	B	C	D	A	A	A
Decane	D	D	D	D	D	D	D	A	A	A
Detergent Solutions	D	D	D	D	D	D	D	A	A	A
Diacetone Alcohol	B	B	A	A	A	A	A	A	A	A
Diamylamine	See Ammonia									
Dibenzyl Ether	D	D	D	D	D	D	D	C	A	A
Dibenzyl Sebacate	D	D	D	D	D	D	D	C	A	A
Dibromobenzene	C	D	B	D	D	C	B	B	A	A
Dibutyl Sebacate	D	D	B	D	D	B	D	B	B	A
Dibutylamine	See Ammonia									
Dibutylether	B	C	C	B	A	C	B	D	A	A
Dibutylphthalate	D	D	B	D	D	D	A	D	A	A
Dicalcium Phosphate	A	A	A	A	A	A	A	A	A	A
Dichloroacetic Acid	D	D	C	D	D	D	C	C	A	A
Dichlorobutane	D	D	D	D	D	D	C	A	A	A
Dichlorodifluoromethane (Freon 12)	D	D	D	B	D	D	D	B	A	A
Dichloroethane	D	D	D	D	D	D	D	A	A	A
Dichloroethyl Ether	D	D	D	D	D	D	D	C	A	A
Dichloroethylene	D	D	D	D	D	D	D	A	A	A
Dichlorohexane	D	D	D	D	D	D	D	A	A	A
Dichloroisopropyl Ether	D	D	C	D	D	D	C	C	A	A
Dichloromethane	D	D	D	D	D	D	D	A	A	A
Dichloropentane	D	D	D	D	D	D	D	A	A	A
Dicyclohexylamine	See Ammonia									
Dieldrin in Xylene	D	D	D	D	D	D	D	A	A	A
Dieldrin in Xylene and Water Spray	D	D	D	B	B	D	D	A	A	A
Diesel Oil	D	D	D	A	B	C	D	A	A	A
Diethanolamine	See Ammonia									
Diethyl Benzene	D	D	D	D	D	D	D	A	A	A
Diethyl Ether	D	D	D	B	C	C	C	D	A	A
Diethyl Oxalate	A	A	A	D	D	D	A	C	A	A
Diethyl Phthalate	D	D	A	D	D	B	C	A	A	A
Diethyl Sebacate	D	D	A	D	D	D	B	C	A	A
Diethyl Sulfate	D	D	B	D	D	D	B	D	A	A
Diethyl Triamine	B	C	A	B	B	C	B	C	A	A
Diethylamine	See Ammonia									
Diethylene Dioxide	D	D	B	D	D	D	B	D	A	A
Diethylenetriamine	See Ammonia									
Dihydroxyethyl Amine	See Ammonia									
Dihydroxyethyl Ether	A	A	A	A	B	A	B	A	A	A
Diisobutyl Ketone	D	D	B	D	D	D	B	D	A	A
Diisobutylene	D	D	D	A	B	D	D	A	A	A
Diisodecyl Adipate	D	D	A	D	D	C	A	C	A	A
Diisodecyl Phthalate	D	D	A	D	D	C	A	C	A	A
Diisooctyl Adipate	D	D	A	D	D	C	A	C	A	A
Diisooctyl Phthalate	B	C	A	B	B	C	A	C	A	A
Diisopropanol Amine	D	D	D	C	D	D	D	A	A	A
Diisopropyl Benzene	D	D	D	B	C	D	D	B	A	A
Diisopropyl Ether	D	D	A	D	D	D	A	D	A	A
Diisopropyl Ketone	D	D	D	D	D	D	D	C	A	A
Dilauryl Ether	D	D	D	D	D	D	D	A	A	A
Dimethyl Benzene	B	C	A	D	C	C	A	D	A	A
Dimethyl Ketone (Acetone)	D	D	A	D	D	D	B	C	A	A

Chemical Resistance	RATING CODE:									
	Natural Rubber	SBR	Butyl	Nitrile	Neoprene	Hypalon	EPDM	Viton	X-Linked Polyethylene	Teflon/TFE/FEF
Dimethyl Phthalate	D	D	A	D	D	D	B	C	A	A
Dimethyl Sulfate	D	D	D	D	D	D	D	D	A	A
Dimethyl Sulfide	D	D	D	D	D	D	D	C	B	A
Dimethylamine	See Ammonia									
Dimethylaniline	D	D	D	D	D	D	D	D	B	A
Dimethylformamide (DMF)	C	C	C	D	C	C	C	D	A	A
Dinitrobenzene	D	D	C	D	C	D	C	A	A	A
Dinitrotoluene	D	D	D	D	D	D	D	C	A	A
Diocetyl Adipate (DOA)	D	D	B	D	D	D	B	C	A	A
Diocetyl Phthalate (DOP)	D	D	B	D	D	D	B	C	A	A
Diocetyl Sebacate (DOS)	D	D	B	D	D	D	B	B	A	A
Diocetylamine	See Ammonia									
Dioxane	D	D	B	D	D	D	B	D	A	A
Dioxolane	D	D	C	D	D	D	B	C	A	A
Dipentene (Limonene)	D	D	D	C	D	D	D	A	A	A
Diphenyl (Biphenyl)	D	D	D	D	D	D	D	A	A	A
Diphenyl Oxide (Phenylether)	D	D	D	D	D	C	D	A	A	A
Dipropyl Ketone	D	D	B	D	D	D	B	D	A	A
Dipropylamine	See Ammonia									
Dipropylene Glycol	A	A	A	A	A	A	A	A	A	A
Disodium Phosphate	A	A	A	A	A	A	A	A	A	A
Divinyl Benzene	D	D	D	D	D	D	D	D	A	A
Dodecyl Benzene	D	D	D	D	D	D	D	A	A	A
Dodecyl Toluene	D	D	D	D	D	D	D	A	A	A
Dow-Per (Perchloroethylene)	D	D	D	C	D	D	D	A	A	A
Dowfume W 40, 100%	D	D	D	D	C	C	C	C	B	A
Dowtherm Oil, A & E	D	D	D	D	D	C	D	A	A	A
Dowtherm S.R.-1	A	A	A	A	A	A	A	A	A	A
Dry Cleaning Fluids	D	D	D	C	D	D	D	A	B	A
Epichlorohydrin	D	D	B	D	D	C	B	D	B	A
Ethanol (Ethyl Alcohol)	A	A	A	A	A	A	A	A	A	A
Ethanolamine	See Ammonia									
Ethers	D	D	C	D	D	C	D	C	A	A
Ethyl Acetate	D	D	B	D	D	D	B	D	A	A
Ethyl Acetoacetate	D	D	B	D	D	D	B	D	A	A
Ethyl Acrylate	D	D	C	D	D	D	D	D	B	A
Ethyl Benzene	D	D	D	C	D	D	D	A	B	A
Ethyl Benzoate	D	D	B	B	C	C	B	C	A	A
Ethyl Butyl Alcohol	A	A	A	A	A	A	A	A	A	A
Ethyl Butyl Amine	See Ammonia									
Ethyl Butyl Ketone	D	D	B	D	D	D	B	D	A	A
Ethyl Celulose	B	B	B	B	B	B	B	D	A	A
Ethyl Chloride	C	C	D	C	C	D	D	A	A	A
Ethyl Dichloride	D	D	D	D	D	D	D	B	B	A
Ethyl Ether	D	D	D	C	D	D	D	D	A	A
Ethyl Formate	D	D	B	D	D	D	C	D	A	A
Ethyl Hexanol	A	A	A	A	A	A	A	B	A	A
Ethyl Methyl Ketone	C	D	B	D	D	D	B	D	A	A
Ethyl Oxalate	A	A	A	D	D	D	B	C	A	A
Ethyl Phthalate	D	D	A	D	D	D	B	C	A	A
Ethyl Propyl Ether	D	D	D	C	D	D	D	C	A	A
Ethyl Propyl Ketone	D	D	B	D	D	D	B	D	A	A
Ethyl Silicate	C	C	A	A	A	A	A	A	A	A
Ethyl Sulfate	D	D	B	D	D	D	B	D	A	A

Chemical Resistance	RATING CODE:									
	Natural Rubber	SBR	Butyl	Nitrile	Neoprene	Hypalon	EPDM	Viton	X-Linked Polyethylene	Teflon/TFE/FEP
Ethylene	D	D	D	A	B	C	D	A	A	A
Ethylene Bromide	D	D	D	C	D	D	D	A	B	A
Ethylene Chloride	D	D	D	C	D	D	D	A	B	A
Ethylene Diamine	See Ammonia									
Ethylene Dibromide	D	D	D	C	D	D	D	B	B	A
Ethylene Dichloride	D	D	D	C	D	D	D	B	B	A
Ethylene Glycol	A	A	A	A	A	A	A	A	A	A
Ethylene Oxide	D	D	C	D	D	D	C	D	C	A
Ethylene Trichloride (Trichloroethylene)	D	D	D	C	D	D	D	A	B	A
EX TRI (Trichloroethylene)	D	D	D	C	D	D	D	A	B	A
Fatty Acids	D	D	D	B	B	B	C	A	A	A
Ferric Bromide	A	A	A	A	A	A	A	A	A	A
Ferric Chloride	A	A	A	A	A	A	A	A	A	A
Ferric Nitrate	A	A	A	A	A	A	A	A	A	A
Ferric Sulfate	A	A	A	A	A	A	A	A	A	A
Ferrous Acetate	D	D	A	D	D	D	B	D	A	A
Ferrous Ammonium Sulfate	A	A	A	A	A	A	A	A	A	A
Ferrous Chloride	A	A	A	A	A	A	A	A	A	A
Ferrous Hydroxide	B	C	A	B	A	B	A	C	A	A
Ferrous Sulfate	A	A	A	A	A	A	A	A	A	A
Fish Oil	D	D	A	A	A	A	A	A	A	A
Fluorine	D	D	D	D	D	D	D	D	D	A
Fluoroboric Acid	A	C	A	A	B	A	A	C	A	A
Fluosilicic Acid	B	B	A	B	B	A	B	A	A	A
Formaldehyde (Formalin)	C	C	A	B	B	B	B	A	A	A
Formamide	A	A	A	A	A	A	A	D	A	A
Formic Acid	B	B	A	C	C	C	D	B	A	A
Freon 11	D	D	D	A	B	A	D	A	A	A
Freon 12	D	D	D	B	C	D	C	B	B	A
Freon 13	A	A	A	A	A	A	A	A	A	A
Freon 13B1	A	A	A	A	A	A	A	A	A	A
Freon 21	D	D	D	D	B	D	D	D	A	A
Freon 22	D	D	A	D	A	D	A	D	A	A
Freon 31	B	B	A	D	A	B	A	D	A	A
Freon 32	A	A	A	A	A	A	A	D	A	A
Freon 112	D	D	D	B	B	B	D	A	A	A
Freon 113	C	B	D	A	A	A	D	B	A	A
Freon 114	A	A	A	A	A	A	A	B	A	A
Freon 114B2	D	C	D	B	A	A	D	B	A	A
Freon 115	A	A	A	A	A	A	A	B	A	A
Freon 142B	A	A	A	A	A	A	A	D	A	A
Freon 152A	A	A	A	A	A	C	A	D	A	A
Freon 218	A	A	A	A	A	A	A	A	A	A
Freon 502	A	A	A	B	A	A	A	B	A	A
Freon BF	D	D	D	B	B	B	D	A	A	A
Freon C316	A	A	A	A	A	A	A	A	A	A
Freon C318	A	A	A	A	A	A	A	A	A	A
Freon MF	D	B	D	A	C	B	D	A	A	A
Freon T-P35	A	A	A	A	A	A	A	A	A	A
Freon T-WD 602	C	B	A	A	B	B	B	A	A	A
Freon TA	A	A	A	A	A	A	A	C	A	A
Freon TC	D	B	A	A	A	A	B	A	A	A
Freon TF	C	B	A	A	A	A	A	A	A	A
Freon TMC	B	C	B	B	B	B	B	A	A	A

Chemical Resistance	RATING CODE:									
	Natural Rubber	SBR	Butyl	Nitrile	Neoprene	Hypalon	EPDM	Viton	X-Linked Polyethylene	Teflon/TFE/FEP
Fuel Oil	D	D	D	A	B	C	D	A	A	A
Fuel, ASTM A	D	D	D	A	A	C	D	A	A	A
Fuel, ASTM B	D	D	D	A	B	C	D	A	A	A
Fuel, ASTM C	D	D	D	B	C	D	D	A	B	A
Fumaric Acid	A	A	D	A	B	B	D	A	A	A
Furan	D	D	C	D	D	D	C	D	A	A
Furfural	D	D	B	D	C	B	B	D	A	A
Furfuryl Alcohol	D	D	C	D	C	C	C	D	A	A
Gallic Acid	A	A	A	B	B	B	B	B	A	A
Gasoline, Hi-Test	D	D	D	A	B	D	D	A	A	A
Gasoline, Lead Free	D	D	D	B	B	D	D	A	A	A
Gasoline, Reg	D	D	D	A	A	C	D	A	A	A
Gelatin	A	A	A	A	A	A	A	A	A	A
Gluconic Acid	D	D	C	C	C	B	C	A	A	A
Glucose	A	A	A	A	A	A	A	A	A	A
Glue	A	A	A	A	A	A	A	A	A	A
Glycerine (Glycerol)	A	A	A	A	A	A	A	A	A	A
Glycols	A	A	A	A	A	A	A	A	A	A
Grease	D	D	D	A	B	C	D	A	A	A
Green Sulfate Liquor	A	A	A	A	B	A	A	B	A	A
Halowax Oil	D	D	D	D	D	D	D	A	A	A
Heptachlor in Petroleum Solvents	D	D	D	B	B	D	D	A	A	A
Heptachlor in Petroleum Solvents, Water Spray	D	D	D	B	B	D	D	A	A	A
Heptanal (Heptaldehyde)	D	D	D	D	D	D	B	D	A	A
Heptane Carboxylic Acid	D	D	C	C	B	B	C	A	A	A
Heptane	D	D	D	A	A	B	D	A	A	A
Hexaldehyde (n-Hexaldehyde)	D	D	B	D	B	C	B	D	A	A
Hexane	D	D	D	A	A	C	D	A	A	A
Hexanol (Hexyl Alcohol)	A	A	A	A	A	A	A	A	A	A
Hexene	D	D	D	B	B	C	D	A	A	A
Hexyl Methyl Ketone	D	D	B	D	D	D	B	D	A	A
Hexylamine (See Ammonia)	See Ammonia									
Hexylene	D	D	D	A	B	D	C	A	B	A
Hexylene Glycol	A	A	A	A	A	A	A	A	A	A
Hi-Tri (Trichloroethylene)	D	D	D	C	D	D	D	A	B	A
Hydraulic Fluid (Petroleum)	D	D	D	A	B	B	D	A	A	A
Hydraulic Fluid (Phosphate Ester Base)	D	D	A	D	D	D	A	D	A	A
Hydraulic Fluid (Poly Alkylene Glycol Base)	B	B	A	A	A	A	A	A	A	A
Hydrobromic Acid	A	D	A	D	C	A	B	A	A	A
Hydrochloric Acid, 5%	A	B	A	C	C	A	B	A	A	A
Hydrochloric Acid, 15%	A	D	B	D	D	A	C	A	A	A
Hydrochloric Acid, 37%	B	D	C	D	D	B	C	C	A	A
Hydrocyanic Acid	B	C	A	B	C	A	B	B	A	A
Hydrofluoric Acid	B	D	B	D	C	A	B	B	A	A
Hydrofluosilicic Acid	A	D	A	D	C	A	B	B	A	A
Hydrogen Gas	B	B	A	A	A	A	B	A	A	A
Hydrogen Peroxide, 3%	A	B	A	B	C	A	B	A	A	A
Hydrogen Peroxide, 10%	D	D	C	D	C	C	C	A	A	A
Hydrogen Peroxide, 30%	D	D	D	D	D	D	C	A	A	A
Hydrogen Peroxide, 90%	D	D	D	D	D	D	C	B	B	A
Hydrogen Sulfide	D	D	A	D	A	B	A	A	A	A
Hydroquinone	B	B	B	D	D	C	B	D	A	A
Hypochlorous Acid	B	B	B	D	B	A	B	A	A	A

Chemical Resistance	RATING CODE:									
	Natural Rubber	SBR	Butyl	Nitrile	Neoprene	Hypalon	EPDM	Viton	X-Linked Polyethylene	Teflon/TFE/FEP
Ink Oil (Linseed Oil Base)	D	D	B	B	B	B	B	A	A	-
Insulating Oil	D	D	D	A	B	D	D	A	A	-
Iodine	D	D	D	D	D	C	D	C	A	A
Iron Acetate	D	D	A	D	D	D	B	D	A	A
Iron Hydroxide	C	C	A	B	A	B	B	C	A	A
Iron Salts	A	A	A	A	A	A	A	A	A	A
Iron Sulfate	A	A	A	A	A	A	A	A	A	A
Iron Sulfide	A	A	A	A	A	A	A	A	A	A
Isoamyl Acetate	D	D	A	D	D	D	B	D	A	A
Isoamyl Alcohol	A	A	A	A	A	A	A	A	A	A
Isoamyl Bromide	D	D	D	D	D	D	D	B	B	A
Isoamyl Butyrate	D	D	C	D	D	D	C	D	B	A
Isoamyl Chloride	D	D	C	D	D	D	D	B	B	A
Isoamyl Ether	D	D	D	D	D	D	D	D	A	A
Isoamyl Phthalate	D	D	A	D	D	D	B	C	A	A
Isobutane	D	D	D	A	A	D	D	A	A	A
Isobutanol (Isobutyl Alcohol)	A	A	A	A	A	A	A	A	A	A
Isobutyl Acetate	D	D	A	D	D	D	B	D	A	A
Isobutyl Aldehyde	C	D	B	D	D	D	B	D	A	A
Isobutyl Amine	B	C	B	D	D	C	B	D	A	A
Isobutyl Bromide	D	D	D	D	D	D	D	B	B	-
Isobutyl Carbinol	A	A	A	A	B	A	A	B	A	A
Isobutyl Chloride	D	D	D	D	D	D	D	B	B	A
Isobutyl Ether	D	D	D	D	D	D	D	D	A	A
Isobutylene	D	D	D	C	C	D	D	A	A	A
Isoctane	D	D	D	A	A	B	D	A	A	A
Isocyanates	C	D	B	D	D	C	B	C	B	-
Isopentane	D	D	D	A	A	D	D	A	B	A
Isopropyl Acetate	D	D	A	D	D	C	B	D	A	A
Isopropyl Alcohol (Iso-propanol)	A	A	A	A	A	A	B	B	B	A
Isopropyl Amine	B	D	B	C	A	C	B	D	A	A
Isopropyl Benzene	D	D	D	D	D	D	D	A	A	A
Isopropyl Chloride	D	D	D	D	D	D	D	B	B	A
Isopropyl Ether	D	D	D	C	D	C	D	D	A	A
Isopropyl Toluene	D	D	D	D	D	D	D	A	A	A
Jet Fuels (JP1-JP6)	D	D	D	A	B	C	D	A	A	A
Ketones	B	B	B	D	D	D	B	D	A	A
Kerosene	D	D	D	A	B	C	D	A	A	A
Lacquer Solvents	D	D	D	D	D	D	D	D	A	A
Lacquers	D	D	D	D	D	D	D	D	A	A
Lactic Acid	B	B	B	A	A	A	B	A	A	A
Lard	D	D	D	A	B	D	C	A	A	A
Lauryl Alcohol	A	A	A	A	A	A	A	B	A	A
Lead Acetate	D	D	A	C	C	D	B	C	A	A
Lead Nitrate	A	A	A	A	A	A	A	A	A	A
Lead Sulfamate	B	B	A	B	A	B	A	A	A	A
Lead Sulfate	A	A	A	A	A	A	A	A	A	A
Ligroin	D	D	D	A	A	D	D	A	A	A
Lime Water	D	D	A	C	A	A	A	A	A	A
Lindol (Tricresyl Phosphate)	D	D	A	D	D	D	A	A	A	A
Linseed Oil	D	D	A	A	B	B	A	A	A	A
Liquid Petroleum Gas	D	D	D	A	B	D	D	A	A	A
Liquid Soap	A	A	A	A	A	A	A	A	A	A
Lubricating Oils	D	D	D	A	B	C	D	A	A	A

Chemical Resistance	RATING CODE:									
	Natural Rubber	SBR	Butyl	Nitrile	Neoprene	Hypalon	EPDM	Viton	X-Linked Polyethylene	Teflon/TFE/FEP
Lye (Sodium Hydroxide)	A	B	A	B	A	A	A	D	A	A
Magnesium Acetate	D	D	A	D	D	D	B	D	A	A
Magnesium Carbonate	A	A	A	A	A	A	A	A	A	A
Magnesium Chloride	A	A	A	A	A	A	A	A	A	A
Magnesium Hydrate	A	B	A	B	A	B	A	B	A	A
Magnesium Hydroxide	A	A	A	A	A	A	B	A	A	A
Magnesium Nitrate	A	A	A	A	A	A	A	A	A	A
Magnesium Sulfate	A	A	A	A	A	A	A	A	A	A
Malathion 50 in Aromatic Solvents	D	D	D	C	C	D	D	A	A	A
Malathion 50 in Aromatic Solvents, Water Spray	D	D	D	A	A	D	D	A	A	A
Maleic Acid	D	D	C	D	C	D	C	A	B	A
Maleic Anhydride	D	D	C	D	C	D	C	A	A	A
Malic Acid	A	B	D	B	C	B	D	A	A	A
Manganese Sulfate	A	A	A	A	A	A	A	A	A	A
Manganese Sulfide	C	A	A	A	B	A	B	A	A	A
Manganese Sulfite	C	A	A	A	B	A	B	A	A	A
Mercuric Chloride	B	B	B	C	C	B	C	A	A	A
Mercury	B	B	A	A	B	A	A	A	A	A
Methacrylic Acid	B	D	D	B	D	B	C	B	A	A
Methane	D	D	D	A	B	D	A	A	A	A
Methyl Acetate	C	D	B	D	D	D	B	D	A	A
Methyl Acrylate	C	D	B	D	C	D	B	D	A	A
Methyl Alcohol (Methanol)	A	A	A	A	A	A	A	C	A	A
Methyl Benzene (Toluene)	D	D	D	D	D	D	D	D	D	A
Methyl Bromide	D	D	B	B	D	D	B	A	A	A
Methyl Butyl Ketone	D	D	B	D	D	D	B	D	A	A
Methyl Cellosolve	D	D	B	C	B	C	B	D	A	A
Methyl Chloride	D	D	B	C	B	C	B	D	A	A
Methyl Cyclohexane	D	D	D	C	D	D	C	B	C	A
Methyl Ethyl Ketone (MEK)	B	D	B	D	D	D	B	D	A	A
Methyl Formate	C	C	B	D	B	C	B	C	B	A
Methyl Hexanol	A	A	A	A	A	A	A	B	A	A
Methyl Hexyl Ketone	D	D	B	D	D	D	B	D	A	A
Methyl Isobutyl Carbinol	B	C	A	B	B	B	A	B	A	A
Methyl Isobutyl Ketone (MIBK)	D	D	B	D	D	D	B	D	A	A
Methyl Isopropyl Ketone	D	D	B	D	D	D	B	D	A	A
Methyl Methacrylate	D	D	D	D	D	B	D	D	B	A
Methyl Propyl Ether	D	D	D	D	D	D	D	A	A	A
Methyl Propyl Ketone	D	D	B	D	D	D	B	D	A	A
Methyl Salicylate	D	D	B	D	D	D	B	C	B	A
Methylene Bromide	D	D	D	D	D	D	D	B	B	A
Methylene Chloride	D	D	D	D	D	D	D	B	A	A
Mineral Oil	D	D	D	A	B	B	D	A	A	A
Mineral Spirits	D	D	D	A	B	D	D	A	A	A
Monochloro difluoromethane (Freon 22)	D	D	A	D	A	D	A	D	A	A
Monochlorobenzene	D	D	D	D	D	D	D	A	A	A
Monoethanolamine (See Ammonia)	See Ammonia									
Monomethylether	B	B	A	A	A	C	A	C	A	A
Monovinyl Acetate	D	D	B	D	D	C	C	A	A	A
Motor Oil	D	D	D	A	A	D	D	A	A	A
Muriatic Acid	See Hcl 37%									
Naphtha	D	D	D	A	B	D	D	A	A	A
Naphthalene	D	D	D	D	D	D	D	A	B	A

Chemical Resistance	RATING CODE:									
	A Excellent B Good C Fair or Conditional D Unsatisfactory – No data available All ratings are based on 70°F									
	Natural Rubber	SBR	Butyl	Nitrile	Neoprene	Hypalon	EPDM	Viton	X-Linked Polyethylene	Teflon/TFE/FEP
Napthenic Acid	D	D	C	D	D	D	D	A	B	A
Natural Gas Contact Titan Tech	Contact Thorburn									
Neatsfoot Oil	D	D	B	A	B	B	B	A	A	A
Neu-Tri (Trichloroethylene)	D	D	D	C	D	D	D	A	B	A
Nickel Acetate	D	D	A	D	D	D	B	D	A	A
Nickel Chloride	A	A	A	A	A	A	A	A	A	A
Nickel Nitrate	A	A	A	A	A	A	A	A	A	A
Nickel Plating Solution	A	D	B	B	C	B	B	A	A	A
Nickel Sulfate	A	A	A	A	A	A	A	A	A	A
Niter Cake	A	A	A	A	A	A	A	A	A	A
Nitric Acid, 10%	D	D	B	D	C	B	B	A	A	A
Nitric Acid, 20%	D	D	B	D	D	B	C	A	A	A
Nitric Acid, 30%	D	D	B	D	D	C	C	A	B	A
Nitric Acid, 30-70%	D	D	C	D	D	D	D	C	C	A
Nitric Acid, Red Fuming	D	D	D	D	D	D	D	D	D	A
Nitrobenzene	D	D	D	D	D	D	D	B	A	A
Nitrogen Gas	A	A	A	A	A	A	A	A	A	A
Nitrogen Tetroxide	D	D	D	D	D	D	D	D	D	A
Nitromethane	B	B	B	D	C	C	B	D	A	A
Nitropropane	C	C	A	D	C	C	B	D	A	A
Nitrous Oxide	A	A	A	A	A	A	A	A	A	A
Octadecanoic Acid	D	D	B	A	B	D	C	C	A	A
Octane	D	D	D	A	B	D	D	A	B	A
Octanol (Octyl Alcohol)	B	B	B	B	A	B	B	A	A	A
Octyl Acetate	D	D	A	D	D	D	B	D	A	A
Octyl Amine	See Ammonia									
Octyl Carbinol	A	A	A	A	A	A	A	B	A	A
Octylene Glycol	A	A	A	A	A	A	A	A	A	A
Oil, Astm #1	D	D	D	A	A	B	D	A	A	A
Oil, Astm #2	D	D	D	A	A	C	D	A	A	A
Oil, Astm #3	D	D	D	A	B	C	D	A	A	A
Oil, Petroleum	D	D	D	A	A	C	D	A	A	A
Oleic Acid	D	D	B	B	C	C	B	C	A	A
Oleum (Fuming Sulfuric Acid)	D	D	D	D	D	D	D	D	D	A
Olive Oil (Non F.D.A.)	D	D	B	A	B	B	B	A	A	A
Orthodichlorobenzene	D	D	D	D	D	D	D	A	B	A
Oxalic Acid	C	C	A	B	C	B	A	C	A	A
Oxygen, Cold	B	B	A	B	B	B	B	A	A	A
Oxygen, Hot	D	D	D	D	D	D	D	B	A	A
Ozone	D	C	B	D	B	A	A	A	A	A
P-Cymene	D	D	D	C	D	D	D	A	A	A
P-Dichlorobenzene	D	D	D	D	D	D	D	A	A	A
Paint Thinner (Duco)	D	D	D	D	D	D	D	C	A	A
Palm Oil	D	D	A	A	B	B	B	A	A	A
Palmitic Acid	D	D	B	A	B	B	B	A	B	A
Papermaker's Alum	A	A	A	A	A	A	A	A	A	A
Paradichlorobenzene	D	D	D	D	D	D	D	A	B	A
Paraffin	D	D	D	A	A	D	D	A	D	A
Paraformaldehyde	D	D	B	B	B	B	B	C	A	A
Peanut Oil	D	D	C	A	B	B	D	A	B	A
Pentane	D	D	A	A	B	D	A	A	B	A
Perchloric Acid	B	B	B	D	A	A	B	A	A	A
Perchloroethylene	D	D	D	C	D	D	D	A	B	A
Petrolatum	D	D	D	A	A	C	D	A	A	A

Chemical Resistance	RATING CODE:									
	A Excellent B Good C Fair or Conditional D Unsatisfactory – No data available All ratings are based on 70°F									
	Natural Rubber	SBR	Butyl	Nitrile	Neoprene	Hypalon	EPDM	Viton	X-Linked Polyethylene	Teflon/TFE/FEP
Petroleum Ether (Naphtha)	D	D	D	A	A	D	D	A	A	A
Petroleum Oils	D	D	D	A	A	C	D	A	A	A
Petroleum, Crude	D	D	D	A	A	C	D	A	A	A
Phenol	C	C	B	D	C	C	C	A	A	A
Phenol Sulfonic Acid	D	D	C	D	C	D	C	A	B	A
Phenyl Chloride	D	D	D	D	D	D	D	A	A	A
Phenylhydrazine	C	D	B	D	D	C	C	A	A	A
Phorone	D	D	A	D	D	D	B	C	A	A
Phosphate Esters	D	D	A	D	D	D	A	C	A	A
Phosphoric Acid, 10%	A	A	A	A	A	A	A	A	A	A
Phosphoric Acid: 10-85%	C	C	A	C	B	A	A	A	A	A
Phosphorous Trichloride	D	D	A	D	D	D	A	A	A	A
Pickling Solution	C	C	C	C	C	C	C	B	A	A
Picric Acid, Molten	C	C	C	C	C	B	C	C	D	A
Picric Acid, Water Solution	A	C	A	B	B	A	B	C	A	A
Pine Oil	D	D	D	C	C	D	D	B	A	A
Pinene	D	D	D	A	D	D	D	A	A	A
Piperidine	D	D	D	D	D	D	D	D	B	A
Pitch	D	D	D	B	B	C	D	C	A	A
Plating Solution, Chrome	D	D	A	B	B	C	A	A	A	A
Plating Solutions, Others	A	A	A	B	B	C	A	B	A	A
Polyethylene Glycol	A	A	A	A	A	A	A	A	A	A
Polypropylene Glycol	A	A	A	A	A	A	A	A	A	A
Polyvinyl Acetate Emulsion (PVA)	C	C	A	C	B	B	A	C	A	A
Potassium Bicarbonate	A	A	A	A	A	A	A	A	A	A
Potassium Bisulfate	A	A	A	A	A	A	A	A	A	A
Potassium Bisulfite	A	A	A	A	A	A	A	A	A	A
Potassium Carbonate	A	A	A	A	A	A	A	A	A	A
Potassium Chloride	A	A	A	A	A	A	A	A	A	A
Potassium Chromate	D	D	A	D	C	C	B	A	B	A
Potassium Cyanide	A	A	A	A	A	A	A	A	A	A
Potassium Dichromate	D	D	A	D	B	C	B	A	A	A
Potassium Hydrate	A	B	A	B	B	B	A	C	A	A
Potassium Hydroxide	A	A	A	A	B	A	A	D	A	A
Potassium Nitrate	A	A	A	A	A	A	A	A	A	A
Potassium Permanganate	D	D	A	D	D	D	A	A	A	A
Potassium Silicate	A	A	A	A	A	A	A	A	A	A
Potassium Sulfate	A	A	A	A	A	A	A	A	A	A
Potassium Sulfide	A	A	A	A	A	A	A	A	A	A
Potassium Sulfite	A	A	A	A	A	A	A	A	A	A
Producer Gas	D	D	D	A	B	B	D	A	A	A
Propane Gas	Use Butane Propane Hose Only									
Propanediol	A	A	A	A	B	A	A	A	A	A
Propyl Acetate	D	D	B	D	D	D	B	D	A	A
Propyl Alcohol (Propanol)	A	A	A	A	A	A	A	A	A	A
Propyl Aldehyde	C	D	B	D	D	D	B	D	A	A
Propyl Chloride	D	D	C	D	C	D	C	B	B	A
Propylene Diamine	See Ammonia									
Propylene Dichloride	D	D	D	D	D	D	D	B	B	A
Propylene Glycol	A	A	A	A	A	A	A	A	A	A
Pydraul Hydraulic Fluids	D	D	B	D	D	D	B	A	B	A
Pyranol	D	D	D	C	D	D	D	A	A	A
Pyridine	D	D	B	D	D	D	B	D	A	A
Pyroligneous Acid	C	C	B	C	B	B	B	A	A	A



Chemical Resistance	RATING CODE:									
	A Excellent B Good C Fair or Conditional D Unsatisfactory – No data available All ratings are based on 70°F									
	Natural Rubber	SBR	Butyl	Nitrile	Neoprene	Hypalon	EPDM	Viton	X-Linked Polyethylene	Teflon/TFE/FEP
Pyrrrole	C	B	B	D	D	D	C	C	A	A
Rape Seed Oil	D	D	A	B	B	B	B	A	B	A
Red Oil (Crude Oleic Acid)	D	D	B	B	B	B	B	A	A	A
Richfield A Weed Killer, 100%	D	D	D	D	D	D	D	C	B	A
Richfield B Weed Killer, 33%	D	D	B	B	B	C	D	C	B	A
Rosin Oil	D	D	D	A	A	B	D	A	A	A
Rotenone and Water	A	A	A	A	A	A	A	A	A	A
Rum	F.D.A. Tube Required									
Sal Ammoniac (Ammonium Chloride)	A	A	A	A	A	A	A	A	A	A
Salicylic Acid	A	B	A	D	D	A	A	A	A	A
Salt Water (Sea Water)	A	A	A	A	A	A	A	A	A	A
Sewage	C	C	C	A	B	A	B	A	A	A
Silicate Esters	D	D	D	B	A	A	D	A	A	A
Silicate of Soda (Sodium Silicate)	A	A	A	A	A	A	A	A	A	A
Silicone Greases	A	A	A	A	A	A	A	A	A	A
Silicone Oils	A	A	A	A	A	A	A	A	A	A
Silver Nitrate	A	A	A	A	A	A	A	A	A	A
Skelly Solvent	D	D	D	A	B	C	D	A	A	A
Skydrol Hydraulic Fluids	D	D	A	D	D	D	A	D	A	A
Soap Solutions	A	A	A	A	A	A	A	A	A	A
Soda Ash (Sodium Carbonate)	A	A	A	A	A	A	A	A	A	A
Soda Niter (Sodium Nitrate)	A	A	A	A	A	A	A	A	A	A
Soda, Caustic (Sodium Hydroxide)	A	B	A	B	A	A	A	D	A	A
Soda, Lime	A	B	A	B	B	B	A	C	A	A
Sodium Acetate	D	A	D	D	D	B	D	A	A	A
Sodium Aluminate	A	A	A	A	A	A	A	A	A	A
Sodium Bicarbonate	A	A	A	A	A	A	A	A	A	A
Sodium Bisulfate	A	A	A	A	A	A	A	A	A	A
Sodium Bisulfite	A	A	A	A	A	A	A	A	A	A
Sodium Borate	A	A	A	A	A	A	A	A	A	A
Sodium Carbonate	A	A	A	A	A	A	A	A	A	A
Sodium Chloride	A	A	A	A	A	A	A	A	A	A
Sodium Chromate	D	D	A	D	C	C	B	C	B	A
Sodium Cyanide	A	A	A	A	A	A	A	A	A	A
Sodium Dichromate	D	D	A	D	C	C	B	C	A	A
Sodium Fluoride	A	A	A	A	A	A	A	A	A	A
Sodium Hydroxide	A	B	A	B	A	A	A	D	A	A
Sodium Hypochlorite	C	D	B	D	D	C	B	A	B	A
Sodium Metaphosphate	A	A	A	A	B	B	A	A	A	A
Sodium Nitrate	A	A	A	A	A	A	A	A	A	A
Sodium Nitrite	A	A	A	A	A	A	A	A	A	A
Sodium Perborate	C	D	A	D	D	D	B	A	A	A
Sodium Peroxide	B	B	A	B	B	B	A	A	B	A
Sodium Phosphate	A	A	A	A	A	A	A	A	A	A
Sodium Silicate	A	A	A	A	A	A	A	A	A	A
Sodium Sulfate	A	A	A	A	A	A	A	A	A	A
Sodium Sulfide	A	A	A	A	A	A	A	A	A	A
Sodium Sulfite	A	A	A	A	A	A	A	A	A	A
Sodium Thiosulfate	A	A	A	A	A	A	A	A	A	A
Soybean Oil	D	D	B	B	B	B	B	A	A	A
Stannic Chloride	A	A	B	A	A	A	A	A	A	A
Stannic Sulfide	A	A	A	A	A	A	A	A	A	A
Stannous Chloride	A	A	A	A	A	A	A	A	A	A
Stannous Sulfide	A	A	A	A	A	A	A	A	A	A

Chemical Resistance	RATING CODE:									
	A Excellent B Good C Fair or Conditional D Unsatisfactory – No data available All ratings are based on 70°F									
	Natural Rubber	SBR	Butyl	Nitrile	Neoprene	Hypalon	EPDM	Viton	X-Linked Polyethylene	Teflon/TFE/FEP
Steam, over 300°F	Steam Hose Only									
Steam, under 300°F	Steam Hose Only									
Stearic Acid	D	D	B	A	B	B	C	A	A	B
Stoddard's Solvent	D	D	D	A	C	D	D	A	A	B
Styrene	D	D	D	D	D	D	D	B	A	B
Sugar Sols. (Sucrose, Non F.D.A.)	A	A	A	A	A	A	A	A	A	A
Sulfamic Acid	C	C	A	B	B	B	A	A	A	A
Sulfite Liquors	B	B	A	B	B	A	B	A	A	A
Sulfonic Acid	D	D	D	D	C	C	D	D	B	C
Sulfur (Molten)	D	D	B	C	C	C	C	A	D	D
Sulfur Chloride	D	D	D	D	D	B	D	A	B	C
Sulfur Dioxide	C	C	B	D	B	B	C	A	A	B
Sulfur Hexafluoride	A	A	A	A	A	A	A	A	A	A
Sulfur Trioxide	D	D	B	D	D	D	C	A	B	B
Sulfuric Acid, 25%	D	D	D	D	B	A	A	A	A	A
Sulfuric Acid, 25-50%	B	D	A	D	C	B	B	A	A	A
Sulfuric Acid, Fuming	D	D	D	D	D	D	D	D	D	D
Sulfurous Acid	B	C	B	C	B	A	B	A	A	A
Tall Oil	D	D	D	C	D	D	D	A	A	B
Tallow	D	D	D	A	A	D	D	A	A	B
Tannic Acid	A	B	A	C	B	B	A	A	A	A
Tar	D	D	D	B	B	D	D	A	D	A
Tartaric Acid	A	A	A	A	B	A	A	A	A	A
Terpineol	D	D	C	D	D	D	C	A	B	A
Tertiary Butyl Alcohol	A	A	A	A	A	A	A	A	A	A
Tetrachlorobenzene	D	D	D	D	D	D	D	B	B	A
Tetrachloroethane	D	D	D	D	D	D	D	A	B	A
Tetrachloroethylene	D	D	D	D	D	D	D	A	B	A
Tetrachloromethane	D	D	D	C	D	D	D	A	B	A
Tetrachloronaphthalene	D	D	D	D	D	D	D	A	B	A
Tetraethyl Lead	D	D	D	B	C	D	D	A	A	A
Tetraethylene Glycol	A	A	A	A	A	A	A	A	A	A
Tetrahydrofuran (THF)	D	D	D	D	D	D	D	D	A	A
Thionyl Chloride	D	D	D	D	D	D	D	B	A	A
Tin Chloride	A	A	A	A	A	A	A	A	A	A
Tin Tetrachloride	A	A	A	A	A	A	A	A	A	A
Titanium Tetrachloride	D	D	D	B	C	C	C	A	A	A
Toluene (Toluol)	D	D	D	D	D	D	D	A	A	A
Toluene Diisocyanate (TDI)	C	C	A	C	D	D	A	B	A	A
Toxaphene	D	D	D	B	B	D	D	A	A	A
Transformer Oils										
(Chlorinated Phenyl Base Askerels)	D	D	D	D	D	D	A	A	B	A
Transformer Oils (Petroleum Base)	D	D	D	A	B	B	D	A	A	A
Transmission Fluids-A	D	D	D	B	C	D	D	A	A	A
Transmission Fluids-B	D	D	D	C	D	D	D	A	A	A
Tributyl Amine	See Ammonia									
Tributyl Phosphate	D	D	B	D	D	D	B	B	A	A
Tricetin	A	B	A	B	B	B	A	D	A	A
Trichlorobenzene	D	D	D	D	D	D	D	B	B	A
Trichloroethane	D	D	D	D	D	D	D	A	A	A
Trichloroethylene	D	D	D	C	D	D	D	A	B	A
Trichloropropane	D	D	D	D	D	D	D	A	A	A
Tricresyl Phosphate (TCP)	D	D	A	D	D	D	B	B	A	A
Triethanolamine (TEA) (See Ammonia)	See Ammonia									

Chemical Resistance RATING CODE: A Excellent B Good C Fair or Conditional D Unsatisfactory – No data available All ratings are based on 70°F	Natural Rubber	SBR	Butyl	Nitrile	Neoprene	Hypalon	EPDM	Viton	X-Linked Polyethylene	Teflon/TFE/FEP
	Trichloroethylene	D	D	D	C	D	D	D	A	B
Trichloropropane	D	D	D	D	D	D	D	A	A	A
Tricresyl Phosphate (TCP)	D	D	A	D	D	D	B	B	A	A
Triethanolamine (TEA)	See Ammonia									
Triethylamine	See Ammonia									
Triethylene Glycol	A	A	A	A	A	A	A	A	A	A
Trinitrotoluene (TNT)	D	D	D	D	B	B	D	B	D	A
Triphenyl Phosphate	D	D	A	D	C	C	B	C	A	A
Trisodium Phosphate	A	A	A	A	A	A	A	A	A	A
Tung Oil	D	D	C	A	B	B	D	A	A	A
Turbine Oil	D	D	D	B	B	B	D	A	A	A
Turpentine	D	D	D	B	B	D	D	A	A	A
2,4D With 10% Fuel Oil	D	D	D	A	A	D	D	A	A	A
Ucon Hydrolube Oils	D	D	A	A	B	D	A	A	A	A
Undecanol	A	A	A	A	A	A	A	B	A	A
Unsymmetrical Dimethyl										
Hydrazine (UDMH)	D	D	A	D	D	A	A	D	A	A
Uran	B	C	B	B	B	A	B	C	A	A
Urea	See Ammonia									
V.M. & P. Naptha	D	D	D	A	A	D	D	A	A	A
Varnish	D	D	D	B	B	C	D	A	A	A
Vegetable Oils	D	D	A	A	B	B	A	A	A	A
Versilube	A	A	A	A	A	A	A	A	A	A

Chemical Resistance RATING CODE: A Excellent B Good C Fair or Conditional D Unsatisfactory – No data available All ratings are based on 70°F	Natural Rubber	SBR	Butyl	Nitrile	Neoprene	Hypalon	EPDM	Viton	X-Linked Polyethylene	Teflon/TFE/FEP
	Vinegar	A	C	A	C	A	A	B	B	A
Vinyl Acetate	D	D	A	D	D	C	C	D	B	A
Vinyl Benzene	D	D	D	D	D	D	D	A	B	A
Vinyl Chloride (Monomer)	C	D	D	D	D	D	D	A	A	A
Vinyl Ether	D	D	D	D	D	C	C	D	A	A
Vinyl Toluene	D	D	D	D	D	D	D	A	B	A
Vinyl Trichloride	D	D	D	D	D	D	D	A	A	A
Water Spray	D	D	D	B	B	D	D	A	A	A
Water, Fresh (Non F.D.A.)	A	A	A	A	A	A	A	A	A	A
Water, Salt	A	A	A	B	A	A	A	A	A	A
Whiskey, Wines	F.D.A. Tube Required									
White Liquor	A	A	B	A	A	A	C	A	A	A
White Oil	D	D	D	A	B	D	D	A	A	A
Wood Alcohol (Methanol)	A	A	A	A	A	A	A	D	A	A
Xylene (Xy101)	D	D	D	D	D	D	D	A	A	A
Xylidine	D	D	D	D	D	D	C	B	A	
Zeolites	A	A	A	A	A	A	A	A	A	A
Zinc Acetate	C	D	A	C	C	C	B	D	A	A
Zinc Carbonate	A	A	A	A	A	A	A	A	A	A
Zinc Chloride	A	A	A	A	A	A	B	A	A	A
Zinc Chromate	A	C	A	A	A	C	A	A	B	A
Zinc Sulfate	A	A	A	A	A	A	A	A	A	A

Elastomeric Temperature and Shelf Life

Elastomers & Fluoroplastics	Min. Material Temperature	Continuous Material Temperature	Intermittent Operating Temperature / Accumulative Time (hrs)**	Shelf Life (yrs)	Resistant To	Generally Attacked By
Chloroprene (CR)	-40°C (-40°F)	107°C (225°F)	121°C (250°F) / 168	36	Moderate Acids & Chemicals, Ozone, Oils, Fats & many Solvents	Oxidizing Acids, Esters & Ketones, Aromatic Chlorinated & Nitro Hydrocarbons
Chlorosulfinated Polyethylene (CSM)	-40°C (-40°F)	121°C (250°F)	177°C (350°F) / 70	60	Strong Acids, Freons, Hydroxides, Ozone, Alcohols, Alkalines & Hydrochlorite Solutions	Ketones, Esters, Some Chlorinated Oxidizing Acids, Chlorinated Nitro & Aromatic Hydrocarbons
Ethylene Propylene Diene Monomer (EPDM)	-54°C (-65°F)	149°C (300°F)***	163°C (325°F) / 300 177°C (350°F) / 200 177°C (350°F) / 150 191°C (375°F) / 70	60	Vegetable & Animal Fats, Oils, Ozone, Ketones, Alcohols, Many Strong & Oxidizing Chemicals	Mineral Oils, Solvents & Aromatic Hydrocarbons
Chlorobutyl (CIIR)	-40°C (-40°F)	149°C (300°F)	177°C (350°F) / 150	32	Vegetable & Animal Oils, Fats, Greases, Air, Gas, Water & Many Oxidizing Chemicals	Oils, Solvents & Aromatic Hydrocarbons
Fluoroelastomer (FKM)	-34°C (-30°F)	204°C (400°F)	288°C (550°F) / 240 316°C (600°F) / 48 343°C (650°F) / 16 371°C (700°F) / 4* 399°C (750°F) / 2*	49	All Aromatic Aliphatic & Halogenated Hydrocarbons, Vegetable & Animal Oils, Many Acids	Ketones, Esters & Nitro Containing Compounds
Silicone (SL)	-51°C (-60°F)	249°C (480°F)	315°C (600°F) / 168	60	Oxidizing Chemicals, Ozone, Concentrated Sodium Hydroxide	Many Solvents, Oils, Concentrated Acids, Sulfurs
Polytetra Fluoroethylene (PTFE)	-79°C (-110°F)	315°C (600°F)	371°C (700°F) / 75	Unlimited	Most Known Fluid Chemicals	Molten Alkali Metals, Fluorine & Related Compounds
Nitrile-Buna Rubber (NBR)	-40°C (-40°F)	107°C (225°F)	121°C (250°F) / 168	15	Most Hydrocarbons, Fats, Oils, Greases, Hydraulic Fluids, Chemicals & Solvents	Ozone, Ketones, Esters, Aldehydes, Nitro & Chlorinated Hydrocarbons, Polar Solvents MEK.
Hydrogenated Nitrile Butadiene Rubber (HNBR)	-54°C (-65°F)	149°C (300°F)	163°C (325°F) / 300	36	Mineral Oil Based Hydraulic Fluids, Animal & Vegetable Fats, Diesel Fuel, Ozone, Sour Gas, Dilute Acids	Aromatic Oils, Polar Solvents, Some Oxygenated Solvents & Aromatic Hydrocarbons

*Fluoroelastomers when reinforced with non-reactive materials have an intermittent temperature capacity of 4 hours at 371°C (700°F) and 2 hours at 399°C (750°F) | ** Excursions at high temperature will have a detrimental effect on useful life of the product | *** Using a Peroxide cure, continuous material temperature is 165°C (329°F)

How to Order Thorburn Handbuilt Rubber Expansion Joints

Part Number Example (Separate segments with dashes): **42HP-6X12-TO-FC-RR-S6-CR5-2-S6-FL2-TLJ**

42HP	6X12	FJ	T	O	F	C	RR	S6	CR5	2	S6	FL2	TLJ
Size		Reinforcement		Arch Type		Rubber Material		Retaining Rings		Restraint Types			
ID X length (Face to Face inches) *ID1-ID2 X length (Reducing EJ's only) Metric specify as follows DN (ID) X length (Face to Face mm) Example DN600X250mm		Standard Polyester/Nylon (Leave Blank) FJ = Fiberglass AR = Aramid Arches N = No arch S = Single D = Double T = Triple Q = Quadruple For arches greater than 4, specify as follows: 5A, 6A, 7A...		F = Filled O = Open Rubber Material A = Natural rubber B = Pure gum C = Neoprene* D = Nitrile* E = Butyl F = Hypalon G = Cross/Link Polyethylene H = EPDM* I = FKM J = PTFE Lined up to 14" FEP Lined 16" and up K = PFA L = Silicone M** = NSF-61 (tube for potable water) N = HNBR O = SBR Z = Non-standard specify		RR = Split RR RL = "L" Shaped RR RI = Integral RR Blank = None Standard thickness 10mm (3/8"), other thicknesses insert "Y" after "R" and specify.		Control Rods - None, Leave Blank CR (Type) - 1, 2, 3, 4, 5, 7 See Page 26 for details Number = QTY of rods (Min. 2) DJ = Dismantling Joint Hinge Type 6H = Hinge 6HU = Universal Hinge Gimbal Type 6G = Gimbal 6GU = Universal Gimbal Accessories Blank = None SW = Spherical Washers* PR = Pressure Ring* VR = Vacuum Ring* XP = Xylan PTFE Coating** TL = Top Hat (Drop-In) Liner* TS = Thor-Shield MC = Metallic Cover V = Specify * Insert Rubber/Metallic material code as applicable ** For CR nuts and rods					
*Thorburn offers FDA compliant white Neoprene, white Nitrile and white EPDM. Add suffix "F" after the Rubber Material Code. **Thorburn offers NSF-61 compliant white nitrile & white EPDM. Add suffix "M" before the Rubber Material Code.													

Expansion Joint Model Numbers

HAND BUILT EXPANSION JOINT STYLES

Round Arch Type Flanged (Pages)

42HP = High pressure (12)
42HPXX = Extra high pressure (13)
42HPW = High pressure wide arch (16)
42HPWV = High pressure wide arch FV (16)
42HPWP = PTFE/FEP Special filled wide arch (17)
62HP = Wide arch low spring rate (18)
62HPVX = Wide arch low spring rate FV (19)
62HPWXX = High pressure wide arch (20-21)
TM21 = Molded wide arch (43)

Spool Type Arch Flanged Reducers

42HP-CR = High pressure concentric reducer (14-15)
42HP-ER = High pressure eccentric reducer (14-15)
42HPOX = Offset (14-15)
42HPEF = Enlarged flange type (14-15)

Low Pressure Sleeve Type

30DB = Cuff sleeve by cuff sleeve (22)

Low Pressure Flanged

15RA = Round low pressure arch type (23)
15RAV = Round low pressure arch type FV (23)
15RRA = Rectangular & Square Arch Type (24)

Full Vacuum U-Type Flanged

15R-HDI = Internal Flange (24)
15R-HDI-A = Internal Flange Arch Type (24)
15R-HDE = External Flange (24)
15R-HDE-A = External Flange Arch Type (24)

Flange Drilling

FL1 = CL150 ANSI B16.5/B16.47, AWWA C207-07, Tbl 2 & 3, Class D. Tbl 4, CL E
FL2 = CL300 ANSI B16.5/B16.47, B16.24, MSS SP-44
FL7 = CL 125 ANSI B16.1/B16.24, CL150 MSS SP-44 **FL3** = PN10 **FL4** = PN16
FL5 = PN25 **FL6** = PN40 **FL8** = British Standard (BS10:2009)
FL9 = JIS Standard B-2212 (Conforms to JIS10KG/CM) **U** = Specify

How to Order Thorburn Spherical Expansion Joints

Part Number Example (Separate segments with dashes): **101-12X8-F-C-FL3-S6-CR5-2-S6-SWS6**

101	12X8	F	C	FL3	S6	CR5	2	S6	SWS6
Model #	Size*	Flange Drilling		Flange & Restraint Material		Accessories			
101 (36) 201 (37) 110-CR (38) 110 (39) 111 (40) 210 (41) 102 (42) 102-HP (42) 301EF (44) 301EF-CR (44) 301EF-ER (44)	ID X FF	See Handbuilt for flange drilling codes		Plated steel (standard) - leave blank. Materials: See Handbuilt metallic material codes above		See Handbuilt accessory codes			
Material Tube & Cover Codes see Models (Page) 101 (36), 201 (37), 110 (39), 111 (40), 210 (41), 102/102HP (42) Models (Hand Built) 301EF, 301EF-CR, 301EF-ER (Refer to Handbuilt rubber codes above)				Restraint Types Blank = No restraint See Handbuilt restraint type codes above Number = QTY of rods (Min. 2)					

- Notes:**
- For anything not listed, insert "X" at the end of the part number and specify
 - Special rubber material, insert "Z" in the part number and specify
 - Non-standard retaining ring thickness, insert "Y" in the part number and specify
 - Non-standard metal material, insert "W" in the part number and specify
 - Non-standard flange drilling, insert "U" in the part number and specify
 - Non-standard accessories, insert "V" in the part number and specify
 - Add suffix "DJ" in the part number for Dismantling Joint (Supplied with built-in nuts, internal retaining rings and control rods/turnbuckles and with additional features such as external covers and spherical washers)

***Spherical expansion joint sizes:**

A. Reducing spherical expansion Joints (ID1-ID2 X length).
 B. Sizes for Models 110-CR, 110, 111, 210 are in mm.
 C. For size codes refer to Handbuilt size codes above.

60TMH Ceramic Lined Rubber Hose Assemblies



Thorburn 60TMH rubber hose lined with ceramic balls composed of a minimum of 96% silica for extreme abrasion and temperature resistance



Thorburn's 60TMH Ceramic lined hose assemblies are custom built in a wide range of sizes and up to a maximum of 15m continuous length.

Features

- Designed for applications that require extreme abrasion resistance.
- The 60TMH high abrasion resistant rubber compound is lined with ceramic balls that are vulcanized into the rubber compound. This feature magnifies the abrasive resistance reducing the frequency of hose replacement
- Thorburn's 60TMH unique ceramic ball design insures flexibility while maintaining impact & wear resistance
- Thorburn's 60TMH hose cover can be corrugated to fit standard aluminum field attachable split flanges.
- In all cases, whether the 60TMH hose assembly, regardless of the end fitting, all wetted parts are ceramic lined.
- For ordering information, See Pages 60-61



Thorburn possesses one of the world's largest crimping machines with a 1000 ton crimping force & 590mm jaw opening

Suction & Discharge

- Light weight and heavy duty
- Water, acids and chemicals
- Cement transfer
- Dry cement and hydraulic pumping

Slurry Handling

- Pump suction & discharge applications
- Abrasive resistant mill slurry lines

Dredging

- Suction applications
- Pipe connecting sleeves

Mine Tailings

- Barge applications
- Pipeline thermal & mechanical movement

Pump Stations

- Suction and discharge applications
- Mobile barge loading/unloading

Oil Suction & Discharge

- General refinery applications
- Ship-to-shore loading/unloading
- Storage tank ground settling

60TMH Hose Applications

Pumping Stations



- Suction and discharge applications
- Mobile barge loading/unloading

Slurry Pumps



- Suction and discharge applications
- Abrasive resistant mill slurry lines

Unloading Terminals



- General refinery applications
- Ship-to-shore loading/unloading
- Storage tank ground settling

Sand & Gravel Dredging



- Barge applications
- Pipe connecting sleeves
- Pipeline thermal & mechanical movement

THORBURN FLEX - Canada
 165 Oneida, Pointe-Claire, Quebec
 Canada, H9R 1A9
 Tel: +1-514-695-8710
 Fax: +1-514-695-1321
 sales@thorburnflex.com



ISCIR Romania | CNCAN Romania | EN 13480-2002 | HAF 604 China | TSG China
 (CRN for all Canadian Provinces)

Thorburn's Global Presence

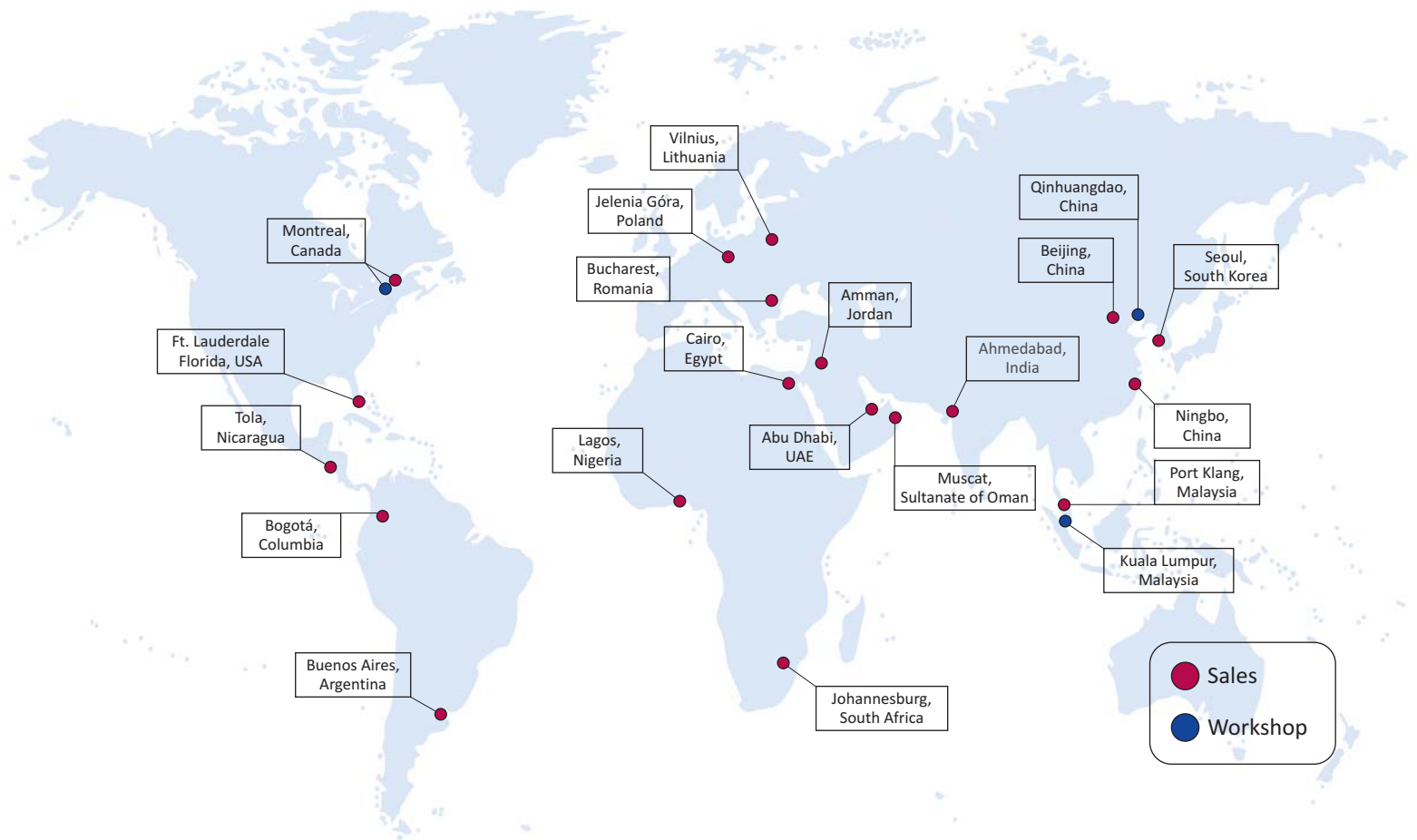

www.thorburnflex.com